

COMMISSION ON COMMUNITY INVESTMENT AND INFRASTRUCTURE

RESOLUTION 14-2018

As Amended by the Commission on April 17, 2018

Adopted April 17, 2018

ADOPTING FINDINGS PURSUANT TO THE CALIFORNIA ENVIRONMENTAL QUALITY ACT AND APPROVING THE HUNTERS POINT SHIPYARD PHASE 2 DESIGN FOR DEVELOPMENT; HUNTERS POINT SHIPYARD REDEVELOPMENT PROJECT AREA

WHEREAS, In furtherance of the objectives of the California Community Redevelopment Law (Health and Safety Code, section 33000 et seq. the “**CRL**”), the Redevelopment Agency of the City and County of San Francisco (the “**Former Agency**”) undertook programs for the reconstruction and construction of blighted areas in the City and County of San Francisco (“**City**”), including the Bayview Hunters Point Redevelopment Project Area (“**BVHP Project Area**”) and the Hunters Point Shipyard Redevelopment Project Area (“**HPS Project Area**”); and,

WHEREAS, The Board of Supervisors of the City and County of San Francisco (“**Board of Supervisors**”) adopted the Hunters Point Shipyard Redevelopment Plan (“**HPS Plan**”) on July 14, 1997 by Ordinance No. 285-97 and amended the HPS Plan on August 3, 2010 by Ordinance No. 211-10 and on June 22, 2017 by Ordinance No. 122-17; and,

WHEREAS, On June 3, 2010, the Former Agency Commission and the San Francisco Planning Commission took several actions approving (or recommending for approval of) a program of development for approximately 702 acres of land within the BVHP Project and HPS Project Areas (“**CP/HPS2 Project**”), including a design for development document that established a vision for development as well as development standards and guidelines constituting the land use controls for the development within Phase 2 of the HPS Project Area (the “**2010 HPS2 Design for Development**”); and,

WHEREAS, Pursuant to California Health and Safety Code §§ 34170 et seq. (the “**Dissolution Law**”), the Former Agency was dissolved as of February 1, 2012; and,

WHEREAS, The Successor Agency to the Redevelopment Agency of the City and County of San Francisco (commonly known as the Office of Community Investment and Infrastructure herein, “**Successor Agency**” or “**OCII**”) is completing the enforceable obligations of the Former Agency with regard to the HPS Project Area, including implementation of the HPS Design for Development and administration of the CP/HPS2 Project, under the authority of the CRL as amended by the Dissolution Law, and under San Francisco Ordinance No. 215-12 (Oct. 4, 2012) (establishing the Successor Agency Commission (“**Commission**”) and delegating to it state authority under the Dissolution Law); and,

- WHEREAS, The Successor Agency adopted an amendment to the HPS Plan (and recommended same for approval to the Board of Supervisors) on April 17, 2018 by Resolution XX-2018 (“**Plan Amendment**”), to facilitate modifications to the CP/HPS2 Project; and,
- WHEREAS, The Plan Amendment consists of the following general changes, among others: (a) retaining the historic street grid within Phase 2 of the HPS Project Area; (b) adjusting the mix of land uses within Phase 2 of the HPS Project Area by reducing the contemplated amount of research and development and office space and providing new uses, including a hotel, institutional uses, and an increase in retail space, and slight reduction to residential uses, while generally maintaining the overall level of nonresidential development within Phase 2 of the HPS Project Area; and (c) allowing for private eco-district infrastructure to serve the CP/HPS2 Project; and,
- WHEREAS, The Commission now proposes to adopt a revised design for development for Phase 2 of the HPS Project Area (“**2018 HPS2 Design for Development**”) which is in conformity with the Plan Amendments and proposed modifications to the CP/HPS2 Project. The 2018 HPS2 Design for Development replaces in its entirety the 2010 HPS2 Design for Development. The 2018 HPS2 Design for Development establishes a new vision for development of Phase 2 of the HPS Project Area, while retaining the goals of the existing 2010 HPS2 Design for Development to rejuvenate Phase 2 of the HPS Project Area and integrate it with the existing Bayview Hunters Point neighborhood to create a vibrant mixed-use district that provides a major focal point to the shoreline area of southeast San Francisco; and,
- WHEREAS, The 2018 HPS2 Design for Development is a companion document to the HPS Plan, as amended, and provides specific design intention and legislated development standards and guidelines that apply to all developments within Phase 2 of the Project Area; and,
- WHEREAS, The Successor Agency will utilize the 2018 HPS2 Design for Development, along with the HPS Redevelopment Plan, in project approval and design review for future improvements and developments in Phase 2 of the HPS Project Area; and,
- WHEREAS, In reviewing and approving development proposals, OCII will continue to work cooperatively with the Planning Department in accordance with those procedures established in that certain Planning Cooperation Agreement (Candlestick Point and Phase 2 of the Hunters Point Shipyard) between OCII and the Planning Department of the City and County of San Francisco dated for reference purposes as of June 3, 2010, but OCII will retain final authority in application of the development controls established in the 2018 HPS Design for Development; and,
- WHEREAS, The Bayview Hunters Point Citizens Advisory Committee considered and recommended approval of the HPS Plan and the 2018 HPS2 Design for Development at its meeting on April 9, 2018; and,

WHEREAS, On April 17, 2018, the Commission adopted Resolution No. 11-2018, by which the Commission determined that the Final EIR (therein defined), together with further analysis provided in Addendum No. 1, Addendum No. 4 and Addendum No. 5, remain adequate, accurate, and objective and in compliance with the California Environmental Quality Act (California Public Resources Code Sections 21000 et seq.) ("CEQA") and the CEQA Guidelines (14 California Code of Regulations Sections 15000 et seq.); and,

WHEREAS, The environmental effects of the 2018 HPS Design for Development have been analyzed in the environmental documents as described in Agency Resolution No. 11-2018. Copies of the environmental documents are on file with the Commission Secretary; now, therefore, be it:

RESOLVED, That the Commission hereby finds that the 2018 HPS Design for Development is included in the actions identified in Resolution 11-2018 for purposes of compliance with CEQA; and be it further

RESOLVED, That in Resolution No. 11-2018, adopted on April 17, 2018, the Commission adopted findings that various actions, including the 2018 HPS Design for Development, were in compliance with CEQA. Said findings are on file with the Commission Secretary and are incorporated herein by reference. Said findings are in furtherance of the actions contemplated in this Resolution and are made part of this Resolution by reference herein; and be it further

RESOLVED, That the 2018 HPS2 Design for Development substantially in the form attached hereto as Exhibit A is hereby approved; and be it further

RESOLVED, That the Commission approval of the 2018 HPS2 Design for Development includes a condition that all necessary City and state agency approvals must be obtained as to the subject of those approvals, and upon the receipt of such City and state agency approvals, OCII Executive Director shall make all conforming changes to the 2018 HPS2 Design for Development without further action by the Commission, and this Resolution shall constitute approval of the 2018 HPS2 Design for Development as so modified; and be it further

I hereby certify that the foregoing resolution was adopted by the Commission at its meeting of April 17, 2018.



Commission Secretary

EXHIBIT A: 2018 Hunters Point Shipyard Phase 2 Design for Development

San Francisco | *California*

HUNTERS POINT SHIPYARD PHASE 2

DESIGN FOR DEVELOPMENT

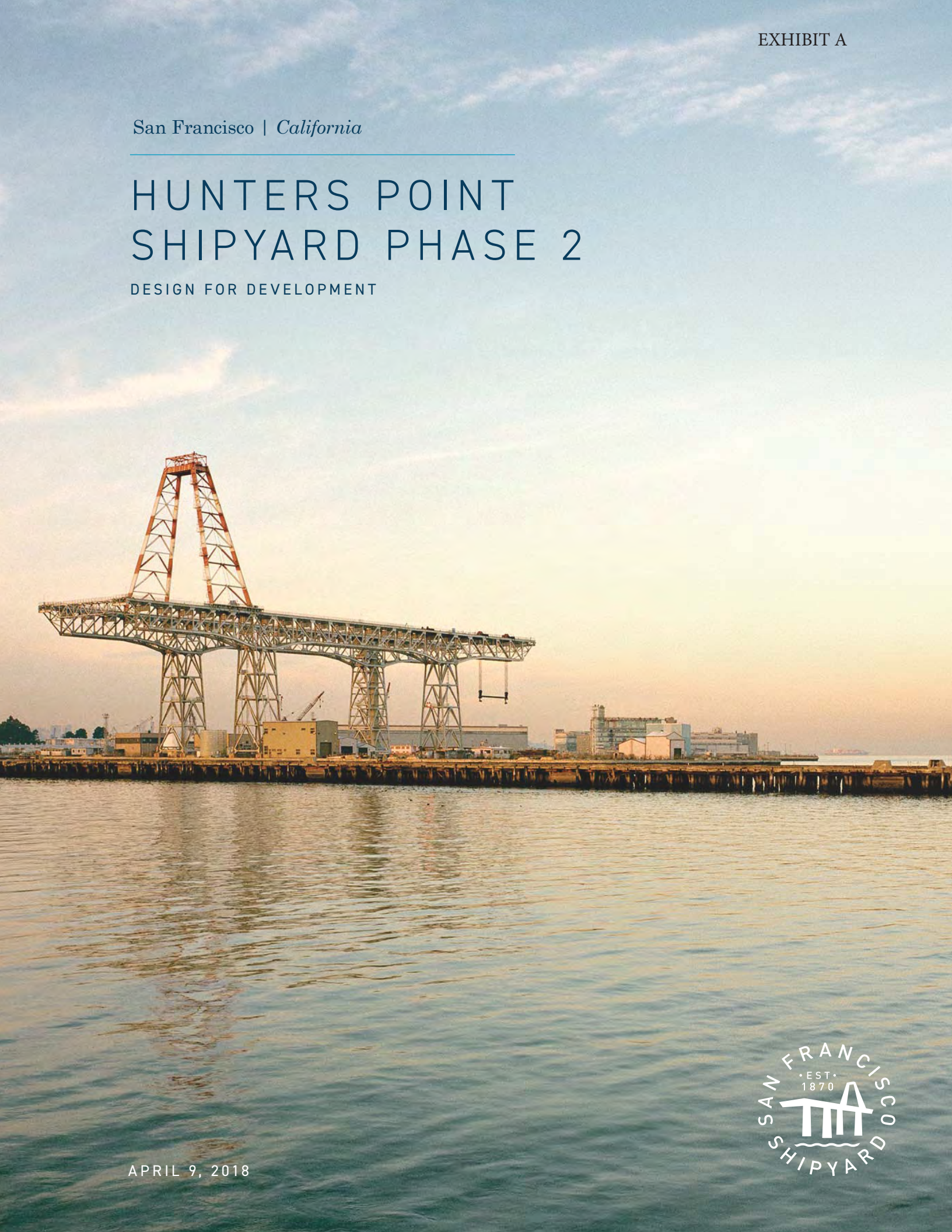

APRIL 9, 2018



ADOPTED _____ BY:

SAN FRANCISCO PLANNING COMMISSION

MOTION NO. _____

COMMISSION ON COMMUNITY INVESTMENT & INFRASTRUCTURE

RESOLUTION NO. _____

Table of Contents

1 Introduction

1.1	Summary of Document	3
1.2	Companion Documents	4
1.3	Document and Chapter Organization	5
1.4	History	8

2 Vision

2.1	Project Vision	18
-----	----------------	----

3 Districts & Features

3.1	Warehouse District	30
3.2	Village Center	32
3.3	Wharf District	34
3.4	North Shoreline	36
3.5	Green Room	38
3.6	Water Room	39
3.7	Pedestrian Allée	40
3.8	Waterfront Open Space	41

4 Building Design Standards & Guidelines

Building Design	50
Private Open Space	134
Signage	146
Lighting	160
Private Infrastructure	162

5 Implementation

5.1 Review and Approval of Design Documents	167
5.2 Deviations and Variances	168
5.3 Process for Amendment of the Design for Development Document	169

6 Appendix

6.1 Checklist	172
6.2 Building Design Application Studies	180
6.3 Sitewide Diagrams	190
6.4 Term Definitions	192
6.5 List of Figures	172
6.6 Image Credits	174

1 INTRODUCTION

1.1	Summary of Document	3
1.2	Companion Documents	4
1.3	Document and Chapter Organization	5
1.4	History	8

1 Introduction



Figure 1.0a: HUNTERS POINT SHIPYARD PHASE 2 SITE LOCATION IN SAN FRANCISCO

1.1 Summary of Document

The 2018 Hunters Point Shipyard Phase 2 Design for Development document (D4D) establishes the design intent, standards, and guidelines that will govern Phase 2 of the Hunters Point Shipyard Redevelopment Project Area (HPS2). The amendment to the HPS2 Redevelopment Plan (Plan) establishes goals to: transform this approximately 421-acre site from a post-military site into thriving neighborhoods; support the construction of market-rate and affordable housing; expand public transit service; and create connections to parks, open spaces, and the waterfront. The Plan governs the land uses in HPS2 and allocates the maximum development square footage for each land use category permitted.

The D4D establishes standards and guidelines for development controls that implement the vision for HPS2 and provide an environment with opportunities for creative and innovative architectural expression. There are additional companion documents which govern different components of the HPS2 development. This D4D includes summaries from these companion documents for reference only—the summaries are not intended to be an exhaustive list of all the relevant content from these documents. This D4D supersedes the HPS2 D4D document approved in 2010.

Throughout this document, Hunters Point Shipyard Phase 1 will be referred to as HPS1 and Hunters Point Shipyard Phase 2 will be referred to as HPS2. While regulated independently, HPS2 is adjacent to HPS1. Hunters Point Shipyard, which includes HPS1 and HPS2, will be referred to as the "Shipyard." The master developer is responsible for the implementation of the Shipyard and Candlestick Point (CP). HPS1 and CP each have a separate D4D. *Figure 1.1a* highlights all three areas where the Office of Community Investment and Infrastructure (OCII) is the primary governing agency.

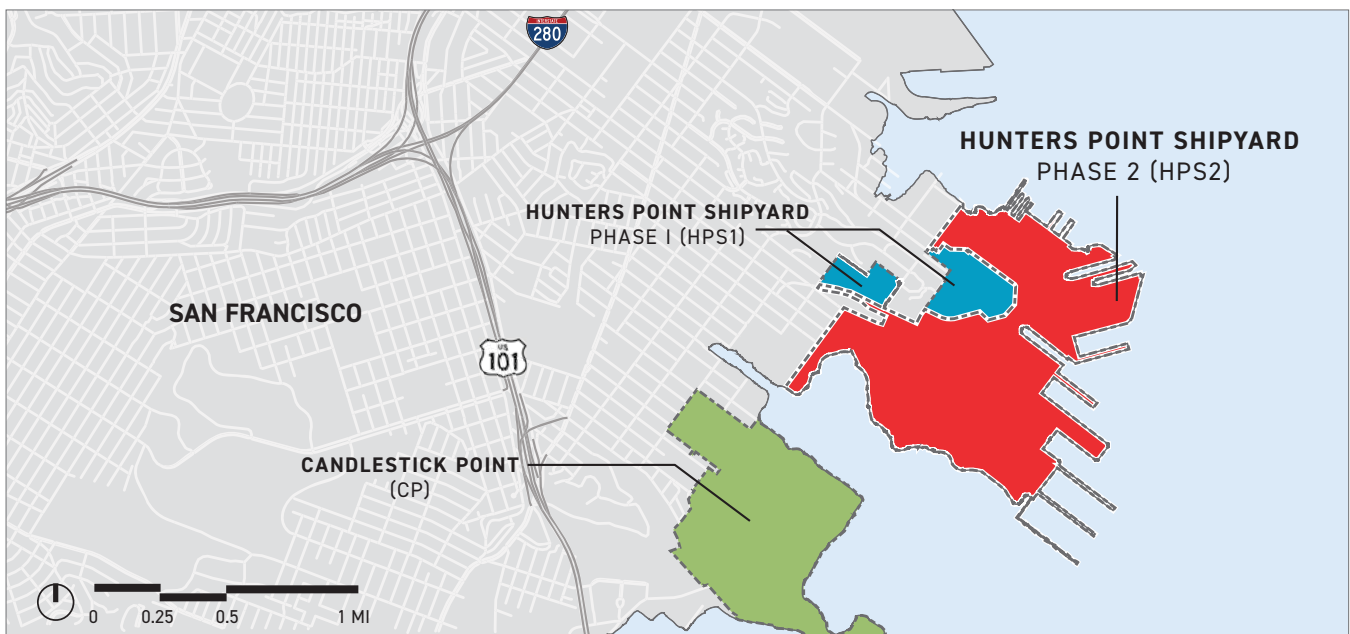

Figure 1.1a: HUNTERS POINT SHIPYARD AND CANDLESTICK POINT BOUNDARY

1.2 Companion Documents

Hunters Point Shipyard Redevelopment Plan: governs permitted land uses and maximum floor areas for each land use in HPS1 and HPS2.

Candlestick Point / Hunters Point Shipyard Phase 2 (CPHPS2) Disposition and Development Agreement (DDA): defines developer obligations to deliver certain infrastructure improvements and community benefits as part of the redevelopment of CP and HPS2.

CPHPS2 Final Environmental Impact Report (and Addenda): describes environmental impacts associated with the construction and operation of development at CP and HPS2, and outlines mitigation measures required of the developer to reduce those environmental impacts.

CPHPS2 Design Review and Document Approval Procedure (DRDAP): defines submittal requirements and the process for approving major and sub-phase applications, as well as Schematic and Design Development documents within CP and HPS2.

CPHPS2 Infrastructure Plan: describes all on-site and off-site infrastructure improvements including utilities and roadways to be constructed in CP and HPS2.

CPHPS2 Parks, Open Space, and Habitat Concept Plan: describes the concept plans for each of the parks and open space areas within CP and HPS2. These areas include the waterfront promenade, neighborhood parks, sports fields, recreational trails linking to the Bay Trail and Blue Greenway, and open spaces dedicated to the restoration of native habitats.

CPHPS2 Sustainability Plan: identifies sustainable design strategies to reduce energy and water demand, improve air quality, and reduce greenhouse gas emissions; defines transportation demand management to minimize auto dependence; and provides plans to enhance the natural environment.

CPHPS2 Transportation Plan: defines the Transit Operating Plan, Transportation Demand Management Program, designated bike routes, and street cross-sections along with parking and loading standards, bicycle facilities, and car-share requirements.

HPS2 Streetscape Master Plan: identifies landscaping, street furnishings, lighting, and paving standards for each neighborhood in HPS2.

HPS2 Signage Plan: defines design standards including color palette, fonts, and sign dimensions for wayfinding and directional signage within the public right-of-way within HPS2.

1.3 Document and Chapter Organization

This D4D opens with an overall vision for HPS2 and its unique districts.

The Design Intent, Standards and Guidelines regulate how this vision will be implemented.

The D4D document has six [6] chapters as follows:

1. **Introduction:** provides the purpose and overview of the D4D, identifies the D4D's relationship to companion documents, and describes the historical context of the Shipyard redevelopment.
2. **Vision:** illustrates the overall concept for HPS2 as well as the relationship between the Shipyard and adjoining communities, specifically in regard to design, character, and connections.
3. **Districts & Key Destinations:** defines the design vision and intent for each of the HPS2 neighborhoods, including urban form, interface and interaction with the public realm, and transportation.
4. **Building Design Standards & Guidelines:** defines the design principles and standards regulating the form and character of buildings, including height, massing, design, signage, and lighting.
5. **Implementation:** offers an overview of the procedures for permitting individual parcels, granting variances, and amending the D4D.
6. **Appendix:** provides definitions and the following site maps for reference to support this D4D: Topography, District and Development Blocks, Land Use, and Phasing.

1.3 Document and Chapter Organization

USER GUIDE

Section Number Section Name

Figures

HUNTERS POINT SHIPYARD PHASE 2 DESIGN FOR DEVELOPMENT | 04.09.2018 DRAFT

3.3 Wharf District

Urban Form

Echoing the Shipyard's Naval period, the Wharf District will become a center for employment, innovation and entrepreneurship. Primarily focused on research and development, the neighborhood may also include light industrial and manufacturing operations as well as residential and ground level commercial uses.

Commercial space will be located within new and restored character-enhancing structures that reflect the needs of the modern workplace. Adhering to the historic street pattern, buildings echo the scale and massing of those that preceded them, with commanding views north, east, and south across the Bay. The generous height and footprint sizes of existing and future buildings relate to the grand scale of the Shipyard.

Public Realm

The Shipyard's primary transit center is located along Spear Avenue, the central axis of the neighborhood. Connecting to the Caltrain Station and Candlestick Point, the transit center also accommodates buses, shuttles, and a future water taxi/ferry service arriving at Dry Dock 4.

The Wharf District offers a unique, accessible, and highly-prized waterfront. The Cultural Heritage Park along Dry Docks 2 and 3 houses a variety of historic buildings and structures dating from the early 1900's, while the Water Room, Dry Dock 4, and the grand stairway provide extraordinary bay views.

1. Building 231
2. Building 253



34 CHAPTER 3 DISTRICTS & FEATURES

3.3 | WHARF DISTRICT

Content

HUNTERS POINT SHIPYARD PHASE 2 DESIGN FOR DEVELOPMENT | 04.09.2018 DRAFT

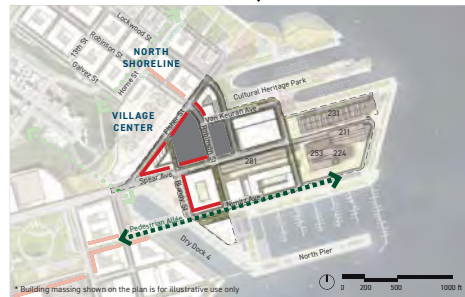

Figure 3.3a: WHARF DISTRICT

- Shared Parking Structures / Utility
- Existing Buildings
- Priority Ground Floor Activation

1. Waterfront Office Example
2. Adaptive Reuse Example



3.3 | WHARF DISTRICT

CHAPTER 3 DISTRICTS & FEATURES 35

Image

Standard Number and Title

Figures

4.1 Block Sizes and Mid-Block Breaks

4.1.1 Mid-Block Break Lot Divisions and Locations

INTENT

Mid-Block Breaks (MBBs) are intended to allow public access through private development blocks to promote connectivity and walkability and create a finer grain circulation system.

MBBs are regulated by the CPSPS2 Infrastructure Plan, Transportation Plan, and Streetscape Master Plan.

Mid-Block Break Specification Book will be provided per the DRDAP.

DEFINITIONS

"Mid-Block Breaks or MBBs"

A publicly accessible pedestrian, bicycle and/or vehicle lane way on private property as identified in Figure 4.1.b.

"Mid-Block Break Width"
The mandatory Street Wall to Street Wall width for a MBB and associated Setback zones.

"EVA"
Emergency Vehicular Access.

"Street Wall"
The aggregate effects of the façades of buildings along a property line adjacent to a street or open space. The typical context for this term is in defining the public realm and framing or engaging the street.

"Block Sizes"
Block Sizes and legal parcels are defined in the Final Map. Approximate parcel dimensions are provided in Figure 4.1a and are subject to change. Block sizes may be legal parcels or may be part of a legal parcel.

STANDARDS

4.1.1 Mid-Block Break Lot Divisions and Locations

Mid-Block Break locations and widths shall be built as defined in Figure 4.1a. MBB Widths shall be used to define the location of the Street Wall. Street Wall to Street Wall dimensions shall not be greater or less than required MBB Width. Refer to Figure 4.1a.

MBB locations across blocks shall be aligned. The first developed MBB establishes the required centerline for subsequent MBB alignment. All required amenities including street trees, lighting, and seating shall occur within the MBB Parcel or the adjacent Setback Zones. Refer to Figure 4.1b and Section 4.27 Private Open Space - Mid-Block Breaks.

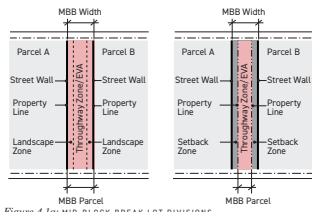

Figure 4.1a: MID-BLOCK BREAK LOT DIVISIONS

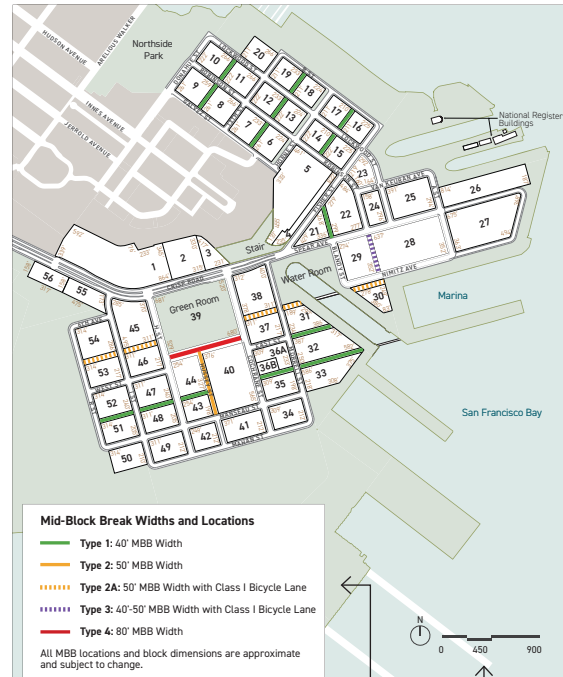

Figure 4.1b: MID-BLOCK BREAK WIDTHS AND LOCATIONS

Intent and Definitions

Standards and Guidelines

Illustrative Graphics

Figure Number and Name

Figure Legend

Scale

1.4 History

HPS2 occupies approximately 421 acres along the southeastern shoreline of San Francisco. The site has extensive waterfront land along the San Francisco Bay to the east and south, South Basin and Yosemite Slough to the west, and India Basin to the north. Hunters Point is relatively protected from the fog and harsh ocean winds that San Francisco is commonly known for. Nomadic Ohlone tribes and immigrant fishing communities have historically called this area home. The site later became a peripheral location within San Francisco, used as a commercial shipyard prior to being purchased and expanded by the US Navy coincident to WWII in the 1940's.

The original topography of the area has changed dramatically over time. Hunters Point Hill originally stretched a half mile into the bay, meeting the water's edge with steep banks. Large portions of the hill were later removed to fill in the end of the peninsula during the making of the Shipyard. Today, HPS2 is mainly characterized by flat topography as it meets the shoreline with constructed wharves, piers, dry docks, and low sea walls.

HPS2 will embrace a new future for the Shipyard by referencing the site's rich history through the design of the landscape and urban form.

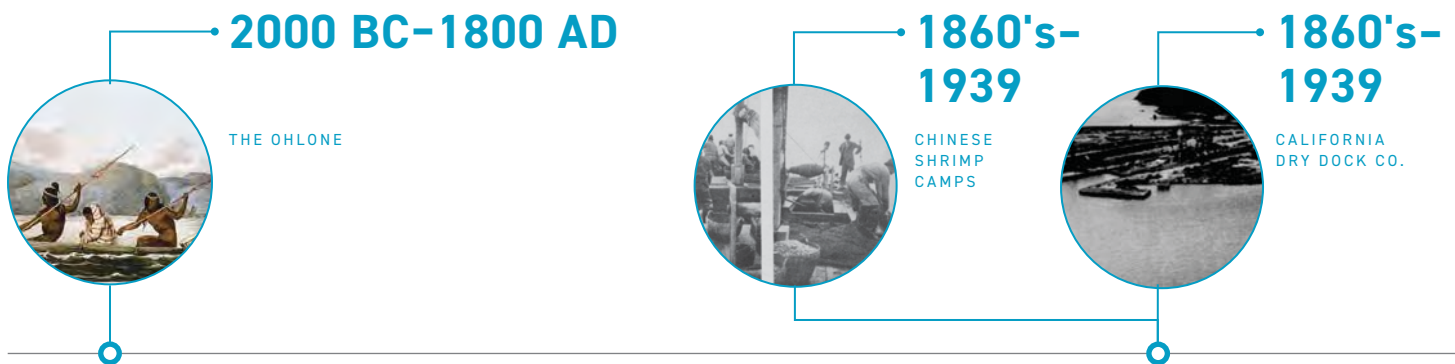

Figure 1.4a: PROJECT HISTORY AND TIMELINE

2000 BC-
1800 AD

The Ohlone

The Shipyard lies within the traditional territory of the indigenous Ohlone (Costanoan) people. Their habitation in close proximity to the San Francisco Bay provided access to clams, ocean and bay mussels, and oysters, which were important components of their diet. The Ohlone carved canoes out of balsa wood and used them to fish and hunt waterfowl and sea mammals. These canoes were also used for travel and trade across the bay waters and salt marshes.

For centuries, the waterfront has played an integral role in the lives of those who have inhabited this area. This powerful interaction between the sea and land will live on through the HPS2 development through waterfront open space promenades, activity areas, and view corridors.

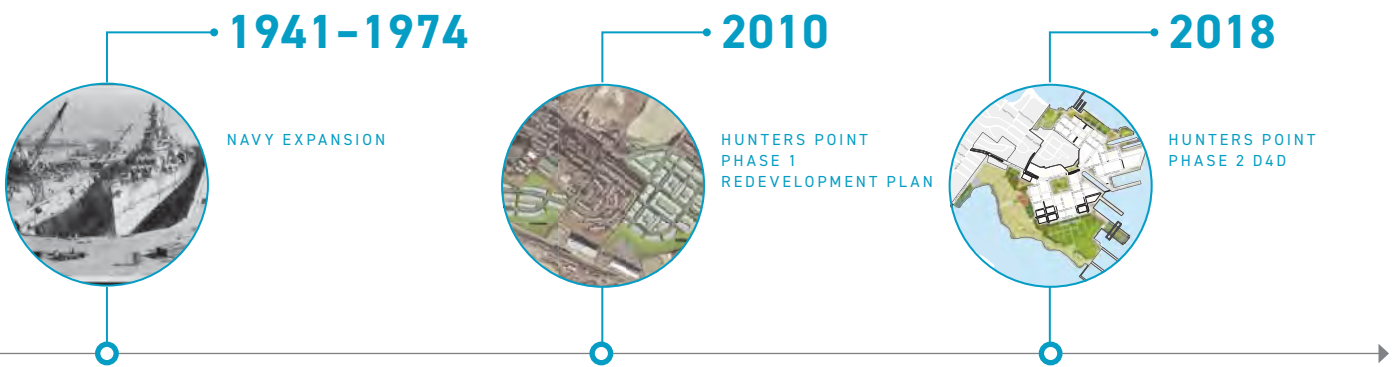

1860's-
1939

Chinese Shrimp Camps

Following the completion of the Transcontinental Railroad, Chinese immigrants who had previously made a living working on the railroad moved west and established shrimp camps. By the late 1860's they had fully developed the shrimping industry at Hunters Point using bag nets. As a result, a substantial amount of dried fish, abalone, abalone shells, and shrimp were exported to China.

Camps included a range of domestic and work-related structures associated with the shrimp industry. Most followed a similar layout, although this changed over time as population, technology, and social conditions altered. Typically, a camp consisted of several small shacks at the water's edge, a wharf, a processing area with boilers, drying grounds, storehouses, and living quarters. The amount of San Francisco fish and shrimp exported overseas led anglers of other ethnicities to petition the State to levy taxes on Chinese commercial fishing. In 1885 and 1886, six hundred Chinese were arrested for tax reasons. The Federal Government revived old trade laws and applied them to the dried fish and shrimp trade; Chinese vessels were seized and their captains fined.

The number of Chinese camps around the San Francisco Bay decreased from 50 in the 1880's to 26 in 1896. The 1900 US Census lists one Chinese fisherman at Hunters Point, but no evidence of large-scale fishing camps in the area. The State Legislature outlawed the bag net in 1910, and most of the shrimp fishermen abandoned the industry. A redesign of the bag net, which facilitated trolling for shrimp, was introduced in the 1920's. By the 1930's, the fishing villages were active once again. No fewer than twelve fishing camps were observed along Hunters Point shoreline.

In 1939, the San Francisco Health Department received a number of complaints surrounding the strong smell emitted by the fishing camps and responded by declaring them unsanitary and ordering several of the camps burned. Fishing activity also declined due to bay fill and pollution, as well as the Navy's move to Hunters Point in the 1940's.

1860's-
1939

California Dry Dock Co.

Access to deep water at the Shipyard drove the nature of its early maritime activities. Small shipyards that had been crowded out of the waterfront closer to the City's center began operating in and adjacent to the Shipyard as early as the 1860's.

Dry Dock 1, completed in 1868, was well situated with deep water and close proximity to the thriving scow schooner boat yards at India Basin just north of the Shipyard. Most of the boats built and repaired during this time at Hunters Point were scow schooners (boats with a broad, shallow hull instead of a deep keel); two boat yards adjacent to the Shipyard in India Basin are known to have built junks (a boat with a flat bottom, no keel, and a very large rudder) for Chinese fishermen.

The dry dock facilities expanded in 1901-1903 with the completion of Dry Dock 2, Buildings 204 (Gate and Pump House) and 205 (Dry Dock No. 2 Pump House). At the time, it was the most modern dry dock on the San Francisco Bay. After the second dock was constructed, Navy ships came to the area for dry dock service. Dry Dock 3 replaced Dry Dock 1 in 1918 in response to the increase in Naval contracts, and Building 140 (Pump House) was constructed in conjunction with this phase of development. In 1939, the Navy purchased the dry docks and adjacent support buildings 207 (Latrine building) and 208 (Shop Service, Tool Room and Canteen Building).

The Hunters Point Commercial Dry Dock Historic District is listed on the National Register of Historic Places (see *Figure 4.24a.*). This Historic District comprises Dry Docks 2, 3, and 4, and Buildings 140, 204, 205, 207 & 208.

1941–
1974

Navy Expansion

The Navy took possession of the Shipyard on December 18, 1941, less than two weeks after the attack on Pearl Harbor. From this point forward, mobilization for WWII occurred rapidly at Hunters Point. As part of the expansion of the Shipyard, a major reclamation project was undertaken to construct Dry Dock Numbers 4, 5, 6, and 7 for docking submarines, destroyers and aircraft carriers. Between December 18, 1941 and September 2, 1945, 661 ships docked at Hunters Point.

Immediately following WWII, Operation Magic Carpet used the Shipyard for the return of US service personnel from overseas. The facility continued to serve as a docking area for Navy ships for repair, overhaul, maintenance, and conversion. Other functions were transferred to the facility, including Ship Salvage Base, 12th Naval District, and the Radiological Defense Laboratory set up along the southern waterfront. Beginning in the early 1950s, the Shipyard began to focus on submarine repair. It was in this capacity that the Shipyard provided support to the US Naval fleet during the Korean and Vietnam conflicts.

Among remnants of the maritime history at the Shipyard are some exceptional character-enhancing buildings and structures that may serve not only to recall the past, but to inform future uses and activities. Retaining and restoring these buildings and maintaining the Navy's historical street network are integral parts of the new development. Existing buildings serve as a relic of the scale and industrial function of the Shipyard. The historic street grid relates to these buildings. WWII Buildings 211, 224, 231, 253, 281, 411, 351, and 813 are being studied for possible retention and adaptive reuse and the iconic Regunning Crane will be retained. In addition, Buildings 101, 140, 204, 205, 207, and 208 will be retained.



1&2. ARCHIVAL IMAGES OF THE WORKING SHIPYARD

1974- PRESENT

Post Military

In 1974, the Navy deactivated the Shipyard and leased the facility to private industry. In 1991, the Base Realignment and Closure Commission identified the Shipyard for closure. Over the next decade, the Navy and the City and County of San Francisco negotiated terms for the lease and subsequent transfer of the facility.

After decommissioning in 1974, the Shipyard was leased in 1976 to a private ship-repair company which sublet buildings to civilians including sculptor Jacques Terzian, a fabricator of found-object furniture and wall installations. Jacques' vision of transforming neglected buildings into affordable workspaces became reality in 1983 when a handful of artists began renting and renovating Shipyard studios. With co-developers Paula Terzian and David Terzian (Jacques' daughter and son), the Shipyard was soon home to 300 visual artists, musicians, and writers. Groups such as the Hunters Point Citizens Advisory Committee, the Shipyard Trust for the Arts and the Shipyard Artist Alliance have worked hard to maintain the vibrancy of this community of arts professionals.

The Bayview Hunters Point neighborhoods adjacent to the Shipyard are predominately home to communities of color that historically included many Shipyard workers and their families. These neighborhoods have had a higher rate of home ownership compared to other neighborhoods within San Francisco, but face a multitude of physical, economic, and social challenges. The US I-280 and CA 101 freeways physically isolate the Bayview neighborhood from the rest of the City. Closure of the Shipyard and de-industrialization of the district in the 1970s and 1980s increased unemployment and local poverty within the Bayview. Racial discrimination, pollution, substandard housing, and lack of investment in infrastructure have been notable and enduring challenges.

Revitalization of the historic Shipyard will create opportunities for housing, employment, open space, transit, and sustainable infrastructure that will complement the growth and resilience of Bayview Hunters Point.



3

3. ARCHIVAL IMAGES OF THE WORKING SHIPYARD

HUNTERS POINT SHIPYARD PHASE 2 DESIGN FOR DEVELOPMENT

2 | VISION

2.1 Project Vision

18

2 | Vision



*"I have great respect for the past.
If you don't know where you've come from,
you don't know where you're going. I have
respect for the past, but I'm a person of
the moment. I'm here, and I do my best
to be completely centered at the place I'm at,
then I go forward to the next place."*

Maya Angelou

Sir David Adjaye selected these words to reflect the vision for Hunters Point Shipyard, which recognizes and respects the history of the place and its connection to the water, sensitively responds to present-day needs, and demonstrates optimism for the future by creating space for the as yet unimagined.

2.1 Project Vision

The San Francisco Shipyard offers a once-in-a-lifetime opportunity to reimagine part of the city at a scale and context rarely encountered. The thinking that informed this Design For Development document is animated by a sense of stewardship, borne out of a recognition of the fact that the built environment created here will endure for generations to come. The aim of this work is to inspire designers to transcend typical notions of standards and compliance so that they may interpret and implement the principles of good city-making and work in keeping with the vision of this document.

Buildings will come and go and be renovated and altered. Permanence lies in the way people experience the spaces between buildings—the human-scaled urban fabric. The vision for the project draws upon the unadulterated authenticity of the Shipyard, continues the legacy of human ingenuity at the site, and creates a model of city-making for San Francisco and the world. The site presents the potential to respond at an impactful scale to some of the Bay Area’s most pressing issues, including access to housing, employment, and economic equality through a series of integrated-use districts that connect with the adjacent Bayview Hunters Point neighborhood. The master plan connects these integrated-use districts with abundant public open spaces, providing a diversity of housing types, and aspires to create sustainable infrastructure that will make the new buildings remarkably efficient.

The site encompasses histories beyond the legacy of the Shipyard. A large open space identified as the Green Room pays homage to Ohlone shell mounds, and interpretive signage will tell the story of the Chinese shrimp camps along the shoreline. The history of the site is connected to the ideals of the future by embracing the monumental scale of potential adaptive reuse buildings, reconciling them with what makes a San Francisco neighborhood distinct, and carrying those qualities through to the design standards for all buildings. Keeping the street grid intact allows for the potential adaptive reuse of a number of existing structures. These “seed buildings” continue an authentic connection with the past.





2
1. Shipyard Existing Photo
2. Shipyard Historic Photo



3
3. Shipyard Existing Photo
4. Shipyard Future Development Example





Figure 2.1a: HPS2 ILLUSTRATIVE PLAN

2.1 Project Vision Cont'd

The master plan incorporates certain commonalities found in San Francisco neighborhoods and adapts them to the unique site of the Shipyard. A prominent Pedestrian Allée, open space connections, and view corridors to the water enhance the public realm, stitch the districts of the site together and create a variation in experience. Features such as the dry dock are revitalized to serve as public gathering spaces framed by structures that have potential for adaptive reuse, taller buildings with a strong street wall, limited setbacks, and vibrant ground floor programming. Active and transparent ground floor storefronts focus the energy of the pedestrian realm along identified streets. A material palette to enhance the experiential texture and patina that is specific to the history of craft at the site is identified along specific streets, view corridors, and within public open spaces, lending a subtle distinctiveness to each district.

The project endeavors to couple the Shipyard's heritage of big ambitions with the small scale granularity of day-to-day human experience of people who will live, work, play, and walk through the site. The Shipyard is envisioned as a place that celebrates the monumentality of its past achievements, including exultant expressions of human ingenuity, and it will continue to be recognizable as a destination for big ideas and bold ambitions, replete with the quality and character of other great San Francisco neighborhoods.

1. Waterfront Open Space Example
2. Ground Floor Dining Example



2.1 Project Vision Cont'd

2.1.1 Embrace the Legacy, Authenticity, and Unique Character of the Shipyard

Situated on the southeastern edge of a city known for its topography, the Shipyard is a uniquely flat maritime landscape with a pronounced connection to the water and the horizon.

Draw Cues from the Scale and Craft of the Shipyard's Heritage Uses to Preserve the Unique Identity of the Site

- Retain the historic buildings and encourage the adaptive reuse of existing character-enhancing structures
- Construct new buildings that respond to the monumental scale of character-enhancing structures
- Incentivize architecture that evokes the legacy of craft and ingenuity at the Shipyard through Adaptive Reuse and Building Materials
- Incentivize adaptive reuse of the unique character-enhancing buildings at Block 28 and Block 40; these structures are of a monumental scale that express the history of the Shipyard. If these blocks are built anew, special requirements to achieve architectural excellence apply



1. Adaptive Reuse Example
2. New Building Example
3. Shipyard Existing Photo
4. Waterfront Open Space Example



Embrace the Maritime Character and Flat Topography of the Shipyards

- Preserve and reinforce views to the water through Building Heights and Setbacks
- Step down the height of buildings at the north and south perimeters of the site to emphasize the natural relationship with and proximity to the waterfront
- Reinforce the height and size of the buildings around the Water Room, Green Room, and Wharf District to meet and address the scale of the adjacent open spaces and water features
- Activate streets with ground floor uses along key corridors
- Activate the ground floor and provide variation in architectural expression along the Pedestrian Allée, which connects a variety of open spaces, residential, retail, and office uses



4

Build on the History of Human Ingenuity at the Site with Exemplary Measures of Large Scale Sustainability

- Aspire to provide state-of-the-art sustainability measures commensurate with the scale of the site which affords the opportunity to reduce its carbon footprint, lessen dependence on non-renewable energy, and significantly reduce water demand
- Create an "Eco-Grid" (subject to financial and regulatory feasibility and the Developer's discretion), which will provide opportunities to:
 - Pursue the implementation of sustainable, district-scale infrastructure
 - Develop a network of sustainable utility and data systems that will reduce impact of the Shipyards on the climate by leveraging the large scale of the site
 - Implement district solar energy generation, recyclable water facilities, and district-wide heating and cooling
 - Establish exemplary best practices for large scale sustainability and resiliency measures
- Leverage the roofs of buildings to accommodate renewable power
- Consider screening parking structure roofs with renewable power
- Allow district energy components within buildings

2.1 Project Vision Cont'd

2.1.2 Create a Model for City-Making That Continues San Francisco's Legacy of Distinct Neighborhoods

San Francisco's distinctive neighborhoods are destinations for residents and global visitors alike. The integrated use districts of this site restore the Shipyard as an engine of economic activity, create space for artists and makers, and benefit the Bayview Hunters Point community. The Shipyard will be reinstated as an economic driver for San Francisco by attracting world-class anchor tenants and research and education institutions. Through its large scale, the project establishes a new, refined approach to workforce urban development.



1



2

Rebuild the Shipyard as a Cultural and Economic Engine for Bayview Hunters Point

- Generate new employment at the Shipyard
- Build community, civic, and institutional resources
- Provide program uses and services that benefit existing neighbors and new residents

Establish Residential Neighborhoods with a Variety of Housing Typologies to Create Diverse Urban Life and Active Streetscapes

- Establish a network of streets and mid-block breaks with active building frontages and proximity to a variety of public open spaces and retail
- Provide residential buildings at various scales and typologies, from multifamily to townhomes
- Design buildings to create an appropriate residential pedestrian street experience

Provide Retail Uses that Activate the Streetscape and Amenities that Build Community

- Design buildings with ground floor activation and transparency to create vibrant, walkable streets
- Prioritize location of retail to focus activity along key streets and walkways
- Use retail and amenities to connect the districts, stimulate mobility, and create places for community gathering

Create Office and R&D Workplaces that Perpetuate San Francisco's Preeminence in the Global Innovation Economy

- Pursue adaptive reuse of select existing character-enhancing structures to create iconic architecture
- Construct new buildings that respond to the scale of existing structures and adjacent open spaces, particularly in the Warehouse and Wharf Districts
- Design large floor plate buildings that preserve flexibility, encourage innovation in workplace design, and attract world-class companies
- Design buildings with attention to architectural detail, quality of materials, and craftsmanship that honor the legacy of ingenuity at the Shipyard

Invigorate the Artistic Cultural District

- Retain Heritage Building 101 and complement it with a new artist studio building and plaza
- Locate active frontages for Artists and Makers along Fisher and Robinson Streets to encourage a vibrant cultural streetscape and destination

- 1. Residential Neighborhood Example
- 2. Residential Street Example
- 3. New Office Building Example
- 4. Office through Adaptive Reuse Example
- 5. Ground Floor Retail Example



3 DISTRICTS & FEATURES

3.1	Warehouse District	30
3.2	Village Center	32
3.3	Wharf District	34
3.4	North Shoreline	36
3.5	Green Room	38
3.6	Water Room	39
3.7	Pedestrian Allée	40
3.8	Waterfront Open Spaces	41

3 Districts & Features



Figure 3.0a: DISTRICTS & FEATURES

Districts

The site will comprise four distinct districts. Each district shares the same guiding principles and development goals, but may differ in the character of the public realm, street typologies, building design, and predominant uses.

- 3.1 Warehouse District:** Architectural diversity in scale and massing reflects the demands of the different uses that make up this District. Building designs celebrate monumentality by responding to the large scale of existing structures, as well as to large public open spaces found in the Green Room and Water Room. Buildings may become smaller in scale along the south waterfront, however, providing a more porous layout and allowing more visual connection from interior blocks to the water.
- 3.2 Village Center:** The Village Center accommodates the resident artist community with new studios and gallery space, supplemented by retail, maker space, and other related uses. The new building complements the distinctive scale and rhythm of Building 101. The architecture is appropriately scaled for a traditional artist community, overlooking a plaza with outdoor workspaces and a display area.
- 3.3 Wharf District:** Primarily focused on research and development, this neighborhood may also include makerspaces as well as ground-level commercial or residential uses. Adhering to the historic street pattern, dry docks, and piers, buildings echo the scale and massing of those that preceded them.
- 3.4 North Shoreline:** Predominately residential, buildings range from low- to mid-rise and are domestic in style and scale. The network of streets make for a walkable neighborhood.

Key Destinations and Features

The following key features bring the districts together:

- 3.5 Green Room:** An eight[8] acre urban park sits at the center of the Warehouse District. The park is a well-designed and highly-maintained urban landscape to engage individuals living and working at the Shipyards.
- 3.6 Water Room:** The Water Room opens up to Dry Dock 4. It provides unobstructed views of the Bay and acts as a powerful urban node, linking the Hilltop and waterfront.
- 3.7 Pedestrian Allée:** A generous 50-foot-wide Pedestrian Allée and East-West bike pathway through the Shipyards connects major public spaces such as the Water Room, Green Room, and the Waterfront. This avenue offers ever-changing experiences across open spaces and the built environment. This procession of environments is complemented with low-rise residential, mid-rise residential, ground floor retail, and offices.
- 3.8 Waterfront Open Spaces:** The waterfront open spaces provide a number of different experiences, such as promenades for walking and bicycling, a marina, sports fields, and an ecological landscape for native habitats. A diversity of waterfront edge conditions provide a variety of experiences as well as access to the water. Some are hard edge conditions (sea walls, rip-rap, ecologically enhanced bulkheads) and others are soft edge conditions (marsh lands, vegetated slopes.)

3.1 Warehouse District

Urban Form

The Warehouse District is a vibrant mixed-use neighborhood centered around the Green Room. The Green Room may be complemented by two existing Navy buildings from the World War II era that frame its northern and southern edges and provide a sense of scale and character. New buildings fronting the Water Room and Green Room respond appropriately to the open spaces.

A thoughtful use of building materials, scale, and massing, provide architectural character, and visual interest, and shape the pedestrian realm. Priorities include creating strong street walls at Crisp Road, the Pedestrian Allée, and around the Green Room; activating the ground floor; and framing key view corridors.

Public Realm

The Pedestrian Allée and bike pathway connects large, naturally landscaped open spaces on the southwestern quadrant of the neighborhood with the Green Room, and continue to bridge Dry Dock 4 and the Wharf District.

The Warehouse District is bordered by the Water Room and grand waterfront open spaces that include acres of baseball and soccer fields, a marina, and large natural landscapes. The Bay Trail extends along the shoreline to provide visual and physical connections to the North Shoreline, the Yosemite Slough Bridge, and Candlestick Point.

Ground floor activation is prioritized in the buildings around the Green Room, the Water Room, and the Pedestrian Allée.

A wastewater treatment facility and a police and fire station are located in this district. The character-enhancing elements of these buildings have been considered in the writing of the D4D.

1. Building 813
2. Building 351
3. Building 411



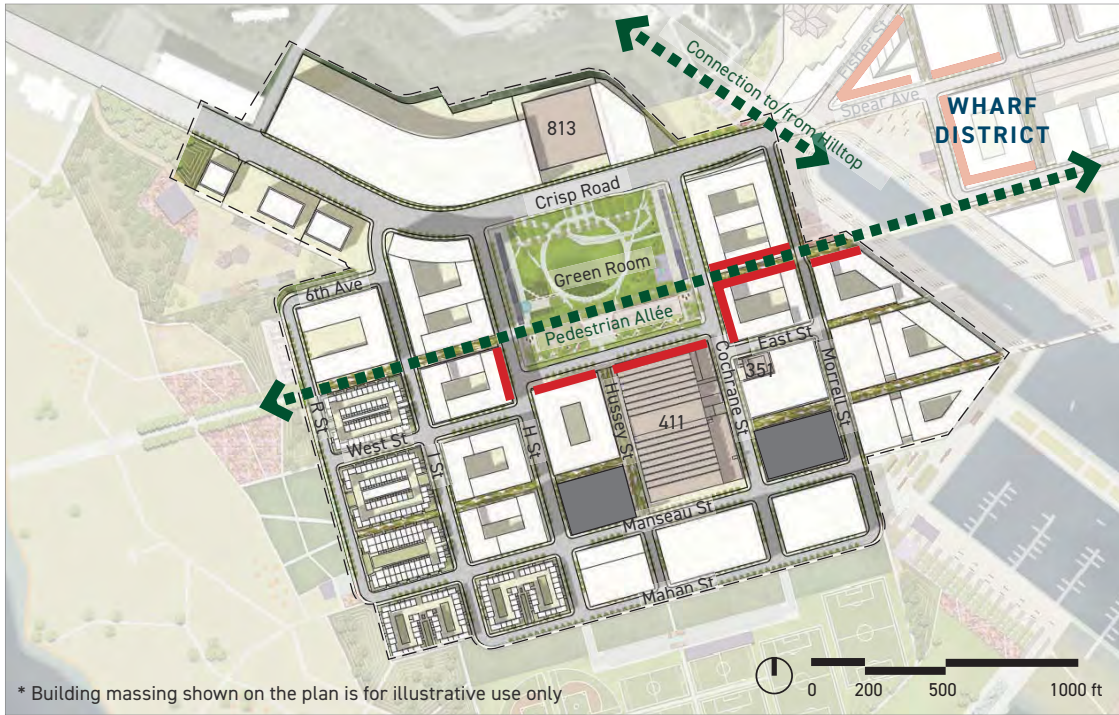
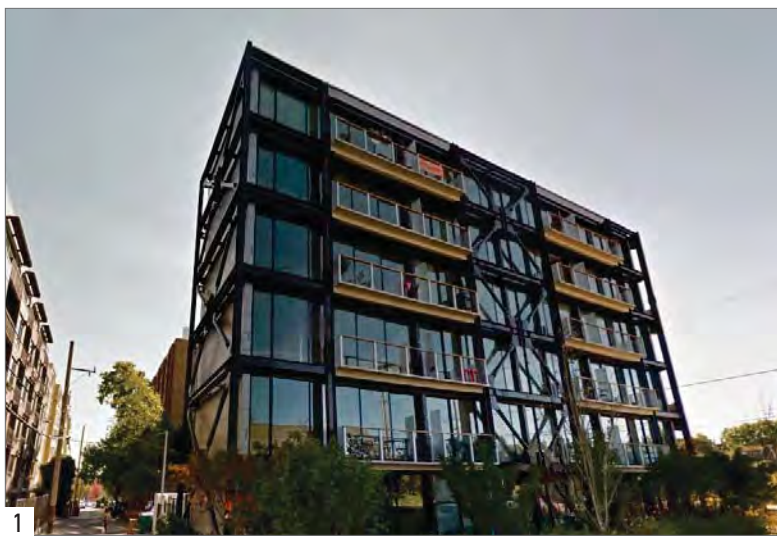

Figure 3.1a: WAREHOUSE DISTRICT



- Shared Parking Structures/Utility
- Existing Buildings
- Priority Ground Floor Activation

1. Mid-Rise Residential Example
2. Open Space Example
3. Ground Floor Activation Example



3.2 Village Center

Urban Form

The Village Center is the creative and cultural hub of the Shipyard and the point of convergence for the other three Shipyard Districts. The Village Center builds on the history of a strong arts and maker community with new artist studios and gallery space supplemented by retail, storefront maker spaces, galleries, and other arts-related uses.

A new Shipyard Artist Studios building frames a plaza for outdoor work spaces and display of artwork. This new building complements the distinctive scale and rhythm of Heritage Building 101, which has been the home for a community of artists since the 1980's.

Public Realm

The nexus of Fischer and Robinson Streets is lined with artists' studios, galleries, and neighborhood retail. The plazas to the north and south of Building 101 provide the primary open space within the Village Center. The low horizontal lines of the Village Center are sharply distinguished from the hillside open space, which rises 85 feet from Fisher to Hilltop Park.

1. Building 101



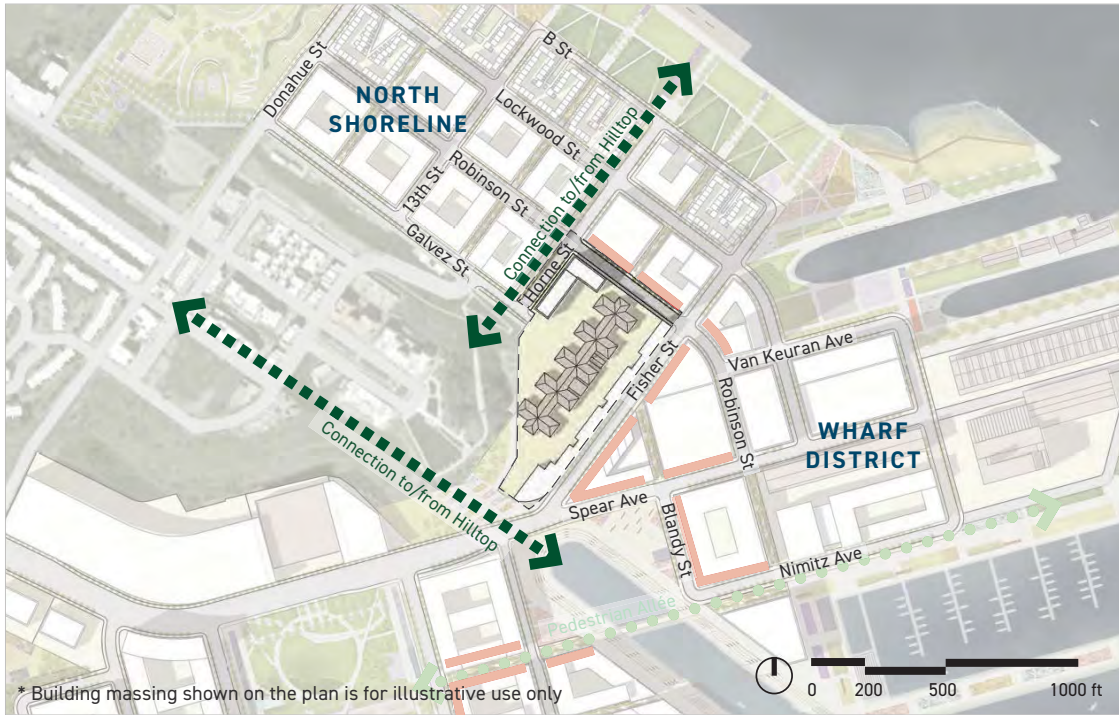

Figure 3.2a: VILLAGE CENTER



■ Building 101 (Artists' Studios)

1 & 2. Artists' Studios Examples
3. Maker Space Examples



3.3 Wharf District

Urban Form

Echoing the Shipyard's Naval period, the Wharf District will become a center for employment, innovation and entrepreneurship. Primarily focused on research and development, the neighborhood may also include light industrial and manufacturing operations as well as residential and ground level commercial uses.

Commercial space will be located within new and restored character-enhancing structures that reflect the needs of the modern workplace. Adhering to the historic street pattern, buildings echo the scale and massing of those that preceded them, with commanding views north, east, and south across the Bay. The generous height and footprint sizes of existing and future buildings relate to the grand scale of the Shipyard.

Public Realm

The Shipyard's primary transit center is located along Spear Avenue, the central axis of the neighborhood. Connecting to the Caltrain Station and Candlestick Point, the transit center also accommodates buses, shuttles, and a future water taxi/ferry service arriving at Dry Dock 4.

The Wharf District offers a unique, accessible, and highly-prized waterfront. The Cultural Heritage Park along Dry Docks 2 and 3 houses a variety of historic buildings and structures dating from the early 1900's, while the Water Room, Dry Dock 4, and the grand stairway provide extraordinary bay views.

1. Building 231
2. Building 253



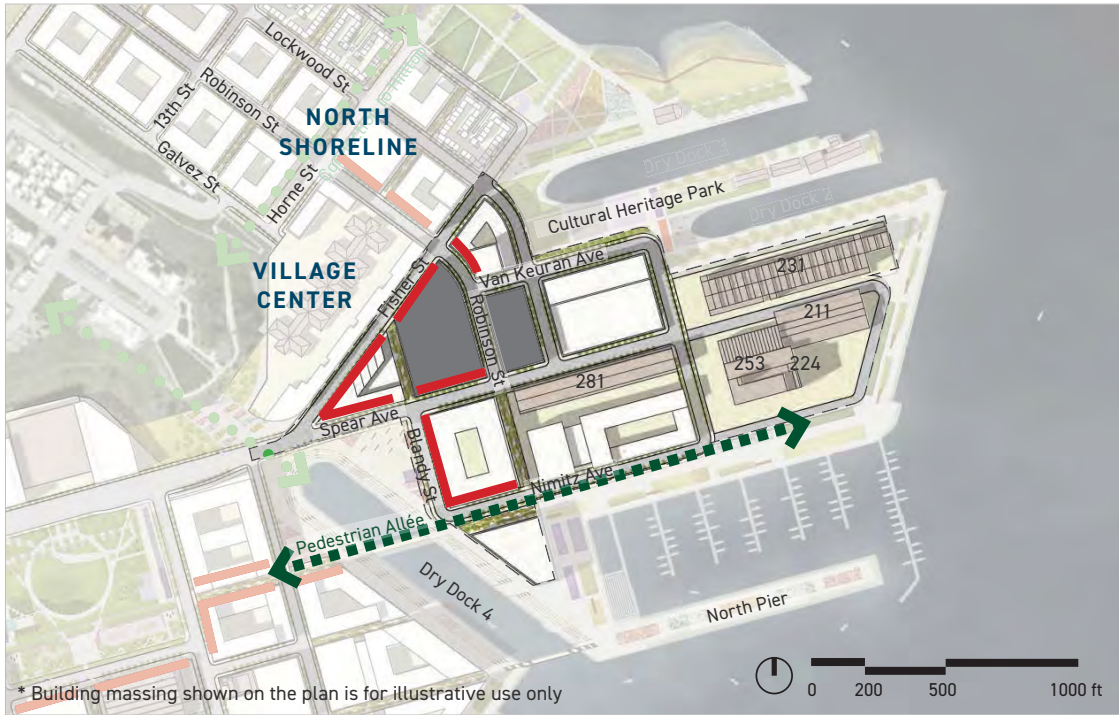

Figure 3.3a: WHARF DISTRICT

- Shared Parking Structures / Utility
- Existing Buildings
- Priority Ground Floor Activation

1. Waterfront Office Example
2. Adaptive Reuse Example



3.4 North Shoreline

Urban Form

Embracing its historic residential legacy, the North Shoreline is the residential heart of HPS2, providing a range of housing types in proximity to the waterfront. Primarily low-to mid-rise, buildings relate directly to adjacent public spaces and rights-of-way, stepping down in height towards the shoreline. Toward the waterfront, buildings may become smaller in scale and less dense in layout, which allows more visual connection from interior blocks to the water. The North Shoreline also includes neighborhood-serving retail and business services, childcare, and small professional offices near Fisher Street and Robinson Street. The iconic high-rise towers located on either side of Fisher Street define the skyline of the Shipyard.

Public Realm

Bicycle-oriented Robinson Street and transit-rich Lockwood Street draw residents from the site's northern gateway at Innes Avenue and Donahue Street into the Shipyard's neighborhood center. A generous setback is designed on Robinson Street and Lockwood Street to enhance the sense of a neighborhood gateway and to allow for private open spaces, stoops and transitions from the private to public realm.

The Waterfront Promenade along the northeastern edge of the neighborhood provides views across the water to downtown San Francisco. Northside Park, at the northern edge of the Shipyard, is a 13-acre area with passive and active open spaces serving both the residents of Shipyard North Shoreline District and the adjoining Hunters Hill and Indian Basin neighborhoods. Both building and park design provide connectivity while also respecting the privacy of residential dwellings adjoining the promenade.

East-west streets, mid-block breaks, and private open spaces extend views to the parks and Waterfront Promenade. This promenade extends the Bay Trail's walking and bike routes into the neighborhood, via a series of paths connecting to neighborhood streets and allées. The broad, landscaped space along Horne Street connects the park into the neighborhood with manicured trees that preserve glimpses of the Bay.

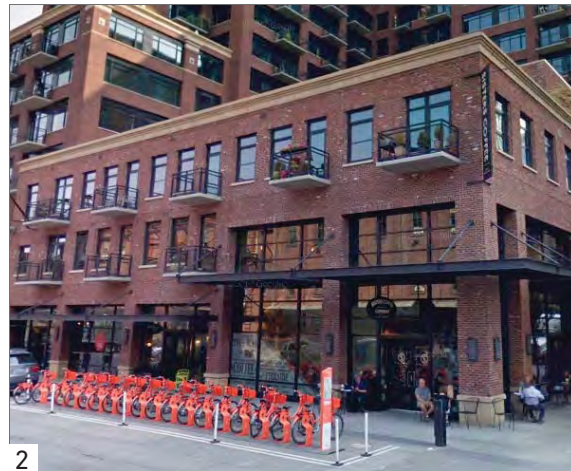

Figure 3.4a: NORTH SHORELINE



- Shared Parking Structures / Utility
- Priority Ground Floor Activation

1. Residential Tower Example
2. Residential Mid-Rise Example



3.5 Green Room

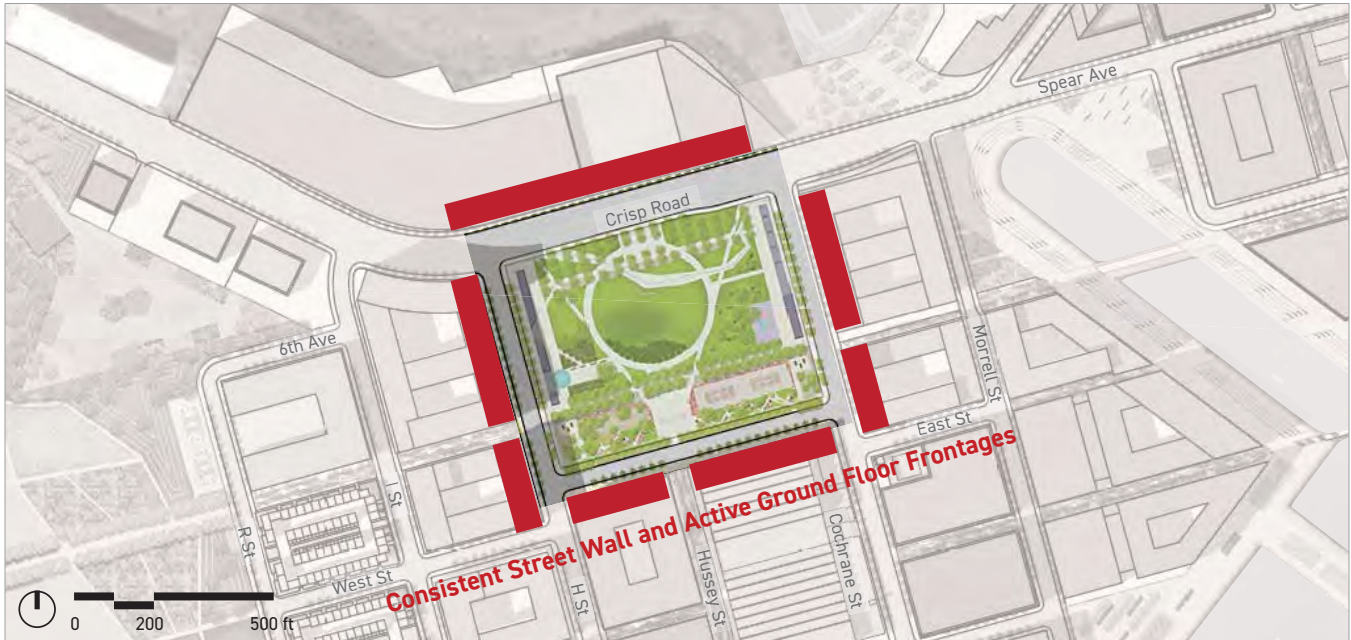

Figure 3.5a: KEY DESTINATIONS AND FEATURES - GREEN ROOM

- New buildings frame the Green Room to reinforce the historic legacy of large buildings through scale, massing, and consistent street walls.
- The district design represents and brings together multiple histories of the Shipyard with iconic adaptive reuse structures.
- One of two outdoor civic "rooms," the Green Room is situated at the heart of the Warehouse District. It is designed as a park with community programs, gatherings, and festivals.
- A pavilion dedicated to Maya Angelou offers a moment of quiet reflection.

1 & 2. Green Room Examples



3.6 Water Room

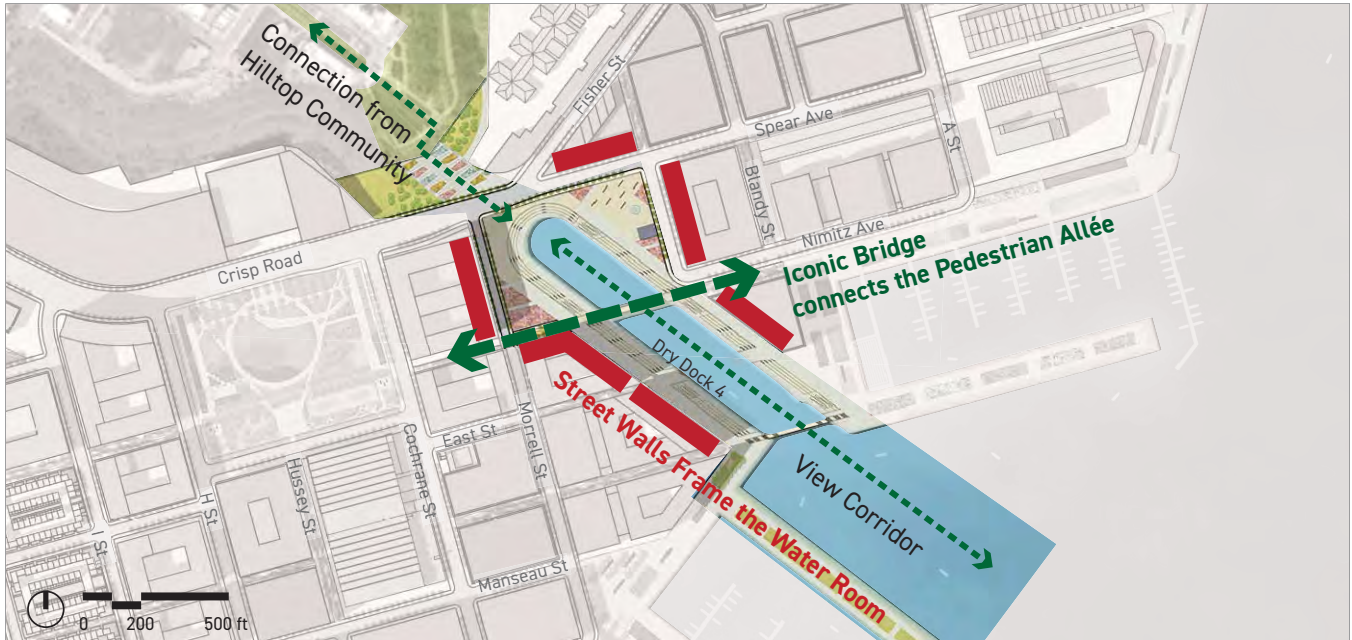

Figure 3.6a: KEY DESTINATIONS AND FEATURES - WATER ROOM

- Buildings around the Water Room are scaled and designed to create consistent street walls that frame this contemporary public space.
- The buildings create an unobstructed view corridor and frame a grand stair with generous access from the top of Hilltop Park down to the Waterfront.
- One of two outdoor civic "rooms," the Water Room is a four-acre civic square that weaves the most striking shoreline feature—Dry Dock 4—into the heart of the shipyard development.
- An iconic bridge connects the Pedestrian Allée.

1 & 2. Water Room Examples



1



2

3.7 Pedestrian Allée

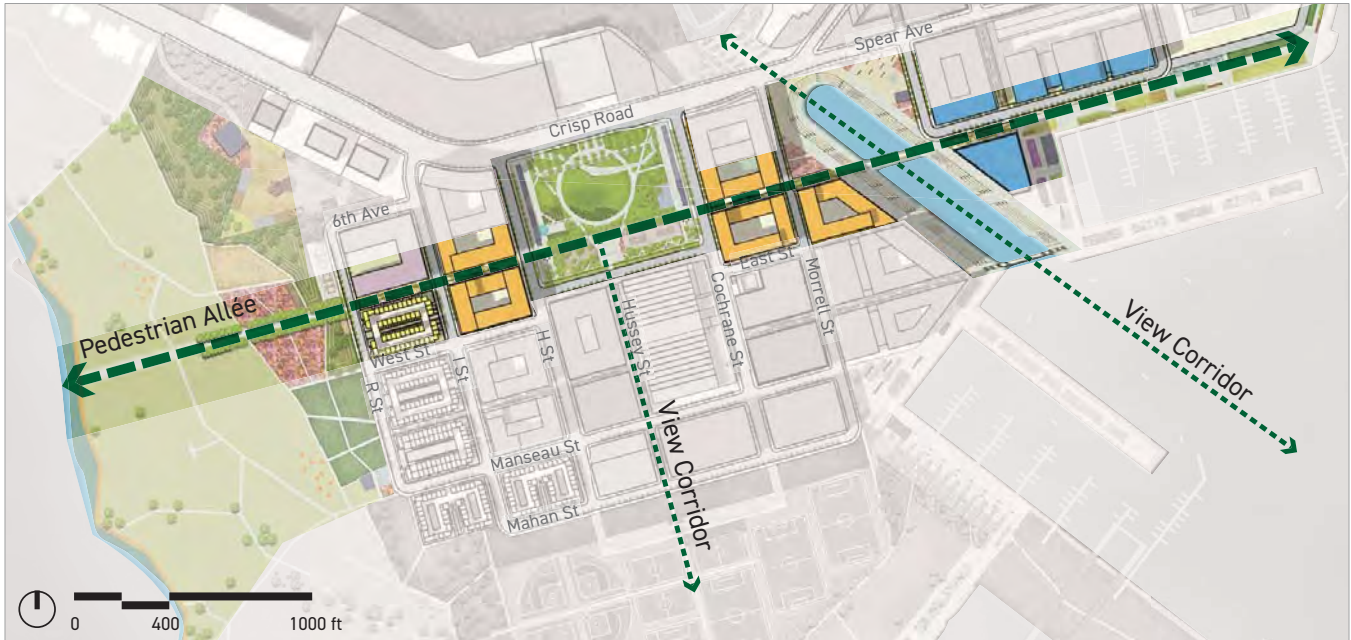

Figure 3.7a: KEY DESTINATIONS AND FEATURES - PEDESTRIAN ALLÉE

- Building Step Backs along the Mid-Block Breaks bring light to the corridor, while the consistent street walls define and frame view corridors.
- Ground Floor Activation at the base of the buildings and concentrated retail zones create a safe and exciting walking experience.
- The sequence of appropriately scaled open spaces—with a mix of low-rise residential, mid-rise residential, office and research buildings, and ground-floor activation—creates multiple experiences.
- A generous east-west pedestrian and bicycle path connects major public spaces such as the Water Room, the Green Room, Waterfront Open Spaces, and the Bay Trail.

1 & 2. Pedestrian Allée Examples



3.8 Waterfront Open Spaces



Figure 3.8a: KEY DESTINATIONS AND FEATURES - WATERFRONT OPEN SPACES

- Through bulk and massing, buildings in districts are scaled appropriately. Compared with the adjacent residential buildings to the north, buildings in the Wharf District increase in scale to emphasize the Dry Docks and Naval piers. Buildings may step down in height towards the northern and southern waterfront open spaces.
- Building parcels along the development perimeter provide access to the waterfront open spaces that host a number of diverse experiences such as promenades for walking, a marina where sailing can dispatch, thriving natural habitats, and a regional sports facility to draw people from across the region.

1 & 2. Waterfront Open Space Examples



HUNTERS POINT SHIPYARD PHASE 2 DESIGN FOR DEVELOPMENT

4 DESIGN STANDARDS & GUIDELINES

4.1-4.25	Building Design	50
4.26-4.27	Private Open Space	134
4.28-4.31	Signage	146
4.32	Lighting	160
4.33	Private Infrastructure	162

4 Design Standards & Guidelines

The Design Standards and Guidelines provide regulatory controls that guide development to align with the HPS2 Vision. Controls consist of Intent, Definitions, Standards, and Guidelines. Certain controls include an Application section that outlines additional information including intent, definitions, and guidance on application of Standards.

Intent: Describes the principal goals, objectives and rationale of each Standard and/or Guideline; as well as alignment of specific features or provisions to the project vision, principles, design drivers and physical framework.

Standard: Mandatory, objective and quantifiable specifications or other requirements applicable to the Project.

Guideline: Mandatory specifications or requirements that are inherently qualitative and therefore require interpretation.

Application: Provides direction on implementation of Standards and Guidelines.

Standards and Guidelines function as a system of controls to shape development consistent with the City and community aspirations for an active, vibrant, livable and distinctive waterfront district. The Intent, Standards, and Guidelines are used to describe and delineate each of the four key development categories: Building Design, Private Open Space, Building Signage, and Building Lighting.

Refer to Chapter 6 for all Term Definitions.



Anticipated Development Map

- R1 Residential Density I (15-75 Units Per Acre)
- R2 Residential Density II (50-125 Units Per Acre)
- R4 Residential Density IV (175-285) Units Per Acre)
- ART Artist or Maker
- CM Commercial (Includes Office, R&D, Retail & Hotel Uses)
- CU Community Use

- OS Parks & Open Space
- U Infrastructure / Utility
- SP Shared Parking Structures*
- Priority Ground Floor Activation

*Shared Parking Structures are permitted on Blocks 1 and 32 (locations to be determined upon Schematic Design approval)

Land uses are governed by the Redevelopment Plan. This figure is an illustrative example that is subject to change.

Block 36B is the currently identified location for the Fire Station lot, subject to change pursuant to the Disposition and Development Agreement (DDA). The Fire Station is exempt from the following:

- Building Setbacks
- Building Height
- Street Wall
- Ground Floor Activation
- Blank Wall

Figure 4.0a: ANTICIPATED DEVELOPMENT MAP *Illustrative use only*

CHAPTER 4 TABLE OF CONTENTS

Building Design

4.1	Block Sizes and Mid-Block Breaks	50	4.8	BE/PE Building and Public Realm Enhancements	88
4.1.1	Mid-Block Break Lot Divisions and Locations	50	4.8.1	Building and Public Realm Enhancement Measures for M, L, XL Buildings	88
4.2	Building Setback	56	BE1	Apply One[1] Additional Bulk/Massing Control	89
4.2.1	Building Setbacks	56	BE2A	Orient Private Courtyards and/or Atria Onto a Public ROW or MBB (Per Street Fronting Elevation)	89
4.2.2	Mid-Block Break Setback	56	BE2B	Orient Private Courtyards and/or Atria Onto a Public ROW or MBB (Multiple Street Fronting Elevations)	89
4.3	Developable Area Coverage	59	BE3	Provide Visual and Physical Access to Interior Courtyard and/or Atrium	89
4.3.1	Developable Area Coverage	59	BE4	Permanently Open Public Access to Open Space	89
4.4	Building Height	60	BE5	Reduction in Floor Plate Area of Upper Floors	90
4.4.1	Building Height	60	BE6	Expressive Entrances	90
4.4.2	MBB Building Stepbacks	62	BE7	Increased Transparency	90
4.4.3	Building Height Exceptions	62	BE8	Distinct Corner Architectural Feature	90
4.4.4	Roof Area Building Height Exception	63	BE9	Roof Expression	91
4.4.5	Street Wall	65	BE10	Additional Active Entrances	91
4.4.6	Implied Façade	65	BE11	Ground Floor Activation Step-Up	91
4.4.7	Street Wall Exceptions for Adaptive Reuse	65	PE1	Public Access through the Building	91
4.4.8	Street Wall Exceptions for Recessed Areas	65	PE2	Public Access through Open Space Connection	91
4.5	Architectural Controls by Building Scale	67	4.9	Tower Controls	92
4.5.1	Architectural Controls by Building Scale	67	4.9.1	Tower Locations	92
4.5.2	Maximum Plan Length	67	4.9.2	Tower Floor Aspect Ratio	92
4.5A	Flow Chart for Architectural Controls	68	4.9.3	Tower Height Variation	92
4.6	FC Façade Composition	70	4.9.4	Tower Massing and Articulation	92
4.6.1	Façade Composition (FC)	70	4.9.5	Tower Mechanical Equipment	92
4.6.2	Block to Block Variation	71	4.9.6	Tower Mechanical Equipment Screening	92
FC1	Façade Modulation Strategies	72	4.10	Projections	94
FC2	Façade Articulation Strategies	76	4.10.1	Projections	94
FC3	Façade Fenestration Strategies	78	4.10.2	Habitable Projections	94
FC4	Material/Color Strategies	80	4.10.3	Non-Habitable Projections	94
4.7	BM Bulk and Massing	81	4.10.4	Other Projections	94
4.7.1	Bulk and Massing Strategies	81	4.10.5	Projection Exemptions	94
BM1	Significant Building Breaks	82	4.10.6	Maximum Projection Area	94
BM2	Upper Floor Stepbacks	84	4.11	Ground Floor Activation	95
BM3	Façade Variation (FV)	86	4.11.1	Zone 1 and 2 Active Entrances	97
			4.11.2	Zone 3 Active Entrances	97
			4.11.3	Active Ground Floor Depth	97
			4.11.4	Ground Floor Height	97
			4.11.5	Waterfront Activation	97
			4.11.6	Guidelines for Ground Floor Residential Design	97
			4.11.7	Ground Floor Activation	98
			4.11.8	Shared Parking Structures Activation	98
			4.11.9	Ground Floor Active Use Transparency	100
			4.11.10	Ground Floor Active Use Glass and Glazing	100

4.12	Building Entries	103
4.12.1	Primary Building Entries	103
4.12.2	Green Room Building Entries	103
4.12.3	Ground Floor Residential Unit Entries	103
4.12.4	Building Entries	103
4.13	Parking and Service Entrances	104
4.13.1	Parking and Service Entrances Locations	104
4.13.2	Combined Parking and Service Entrances	104
4.13.3	Separate Parking and Service Entrances	104
4.13.4	Maximum Parking and Service Entrances	104
4.13.5	Parking and Service Entrances	104
4.13.6	Parking and Service Entrances (Blocks 38 & 45)	104
4.14	Screening	106
4.14.1	Screening	106
4.14.2	Screening of Utilities Visible at Grade	106
4.14.3	Screening Materials	107
4.14.4	Screening for Rooftop Equipment	107
4.14.5	Screening for Upper Floor Parking	107
4.14.6	Screening for Ground Floor Parking	107
4.14.7	Rooftop Screening for Parking	107
4.15	Shared Parking Structures	108
4.15.1	Shared Parking Structure Locations	108
4.15.2	Number of Shared Parking Structures	108
4.15.3	Shared Parking Structure Design	108
4.15.4	Convertible Shared Parking Structures	108
4.15.5	Floor Heights for Convertible Shared Parking Structures	109
4.15.6	Shared Parking Structure Lighting	109
4.15.7	Shared Parking Structure Ground Floor Uses	109
4.16	Rooftops	110
4.16.1	Rooftop Façades	110
4.17	Blank Walls	112
4.17.1	Ground Floor Blank Walls	112
4.17.2	Upper Floor Blank Walls	112
4.18	Daylight	113
4.18.1	Residential Daylight	113
4.18.2	Commercial Daylight	113

4.19	Façade Material	114
4.19.1	Bird-Safe Design	114
4.19.2	Material Quality	114
4.19.3	Material Selection	114
4.19.4	Ground Floor Materials	114
4.19.5	Marine Environment Materials	114
4.19.6	Prohibited Materials	114
4.20	Class I - Bicycle Parking	123
4.20.1	Bicycle Parking Capacity	123
4.20.2	Bicycle Parking Location	123
4.21	Vehicular Parking and Loading	124
4.21.1	Vehicle Parking and Loading	124
4.22	Skyway Connections	126
4.22.1	Skyway Connections	126
4.23	Green Room Datum	128
4.23.1	Green Room Datum	128
4.24	Adaptive Reuse	130
4.24.1	Adaptive Reuse	130
4.24.2	Adaptive Reuse Exemptions	132
4.25	Key Sites Blocks 28 and 40	133
4.25.1	Key Sites Blocks 28 & 40	133

Private Open Space

4.26	Private Open Space	134
4.26.1	Private Open Space	134
4.26.2	Private Common Open Space on Waterfront Blocks	134
4.26.3	Private Setbacks	134
4.26.4	Fences	134
4.26.5	Defensible Space	135
4.26.6	Orientation	135
4.26.7	Planting Palette	135
4.26.8	Irrigation	135

4.27	Private Open Space - Mid-Block Breaks	144
4.27.1	Public Access	144
4.27.2	Throughway Dimensions	144
4.27.3	Surfaces	144
4.27.4	Street Trees	144
4.27.5	Lighting	144
4.27.6	Community Spaces	145
4.27.7	Landscaping	145
4.27.8	Minimizing Vehicular Speeds	145

Signage

4.28	Building Signage	146
4.29	All Signs	148
4.29.1	Transparency	148
4.29.2	Concealed Electrical Signage Elements	148
4.29.3	Typefaces & Colors	148
4.29.4	Sign Materials	148
4.29.5	Graphic Style	148
4.29.6	Integration	148
4.29.7	New Technology Signs	149
4.29.8	Sign Illumination	149
4.29.9	Prohibited Signage	150
4.30	Permanent Signs	151
4.30.1	Commercial Wall Signage	151
4.30.2	Storefront and Retail Wall Signage	152
4.30.3	Residential Wall Signage	152
4.30.4	Projecting Signs	153
4.30.5	Window Signs	154
4.30.6	Identifying, Freestanding, or Directional Signs	155
4.30.7	Canopy/Awning Signage	156
4.30.8	Street or Unit Address Signs Nameplates	157
4.31	Temporary Signs	158
4.31.1	Temporary Signs	158
4.31.2	Portable Signs	159

Lighting

4.32	Building Lighting	160
4.32.1	Glare Reduction	160
4.32.2	Energy Consumption	160
4.32.3	Building Entrances	161
4.32.4	Dark Sky	161
4.32.5	Dark Sky Exemption	161

Private Infrastructure

4.33	Private Infrastructure	162
4.33.1	Odor Control at the Recycled Water Facility	162
4.33.2	Screening of Eco-District or Eco-Grid Utilities Visible at Grade	162

This page is intentionally left blank.

4.1 Block Sizes and Mid-Block Breaks

4.1.1 Mid-Block Break Lot Divisions and Locations

INTENT

Mid-Block Breaks (MBBs) are intended to allow public access through private development blocks to promote connectivity and walkability and create a finer grain circulation system.

MBBs are regulated by the CPHPS2 Infrastructure Plan, Transportation Plan, and Streetscape Master Plan.

Mid-Block Break Specification Book will be provided per the DRDAP.

DEFINITIONS

"Mid-Block Breaks or MBBs"

A publicly accessible pedestrian, bicycle and/or vehicle lane way on private property as identified in *Figure 4.1.b*.

"Mid Block Break Width"

The mandatory Street Wall to Street Wall width for a MBB and associated Setback zones.

"EVA"

Emergency Vehicular Access.

"Street Wall"

The aggregate effects of the façades of buildings along a property line adjacent to a street or open space. The typical context for this term is in defining the public realm and framing or engaging the street.

"Block Sizes"

Block Sizes and legal parcels are defined in the Final Map. Approximate parcel dimensions are provided in *Figure 4.1b* and are subject to change. Block sizes may be legal parcels or may be part of a legal parcel.

STANDARDS

4.1.1 Mid-Block Break Lot Divisions and Locations

Mid-Block Break locations and widths shall be built as defined in *Figure 4.1a*. MBB Widths shall be used to define the location of the Street Wall. Street Wall to Street Wall dimensions shall not be greater or less than required MBB Width. Refer to *Figure 4.1a*.

MBB locations across blocks shall be aligned. The first developed MBB establishes the required centerline for subsequent MBB alignment. All required amenities including street trees, lighting, and seating shall occur within the MBB Parcel or the adjacent Setback Zones. Refer to *Figure 4.1b* and Section 4.27 Private Open Space - Mid-Block Breaks.

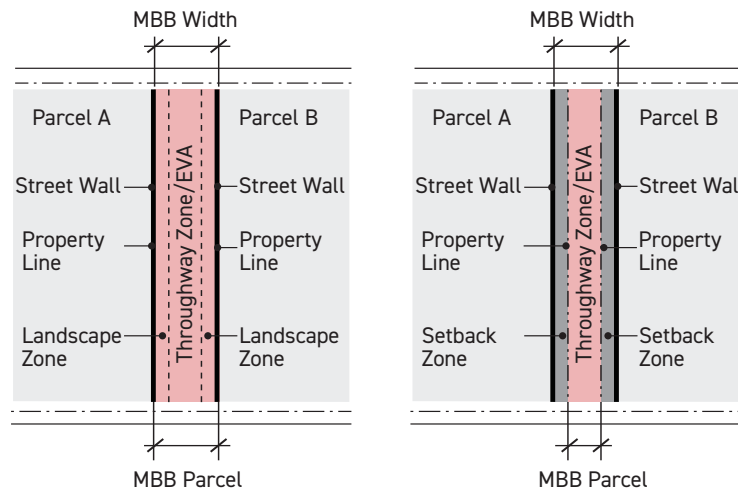

Figure 4.1a: MID-BLOCK BREAK LOT DIVISIONS

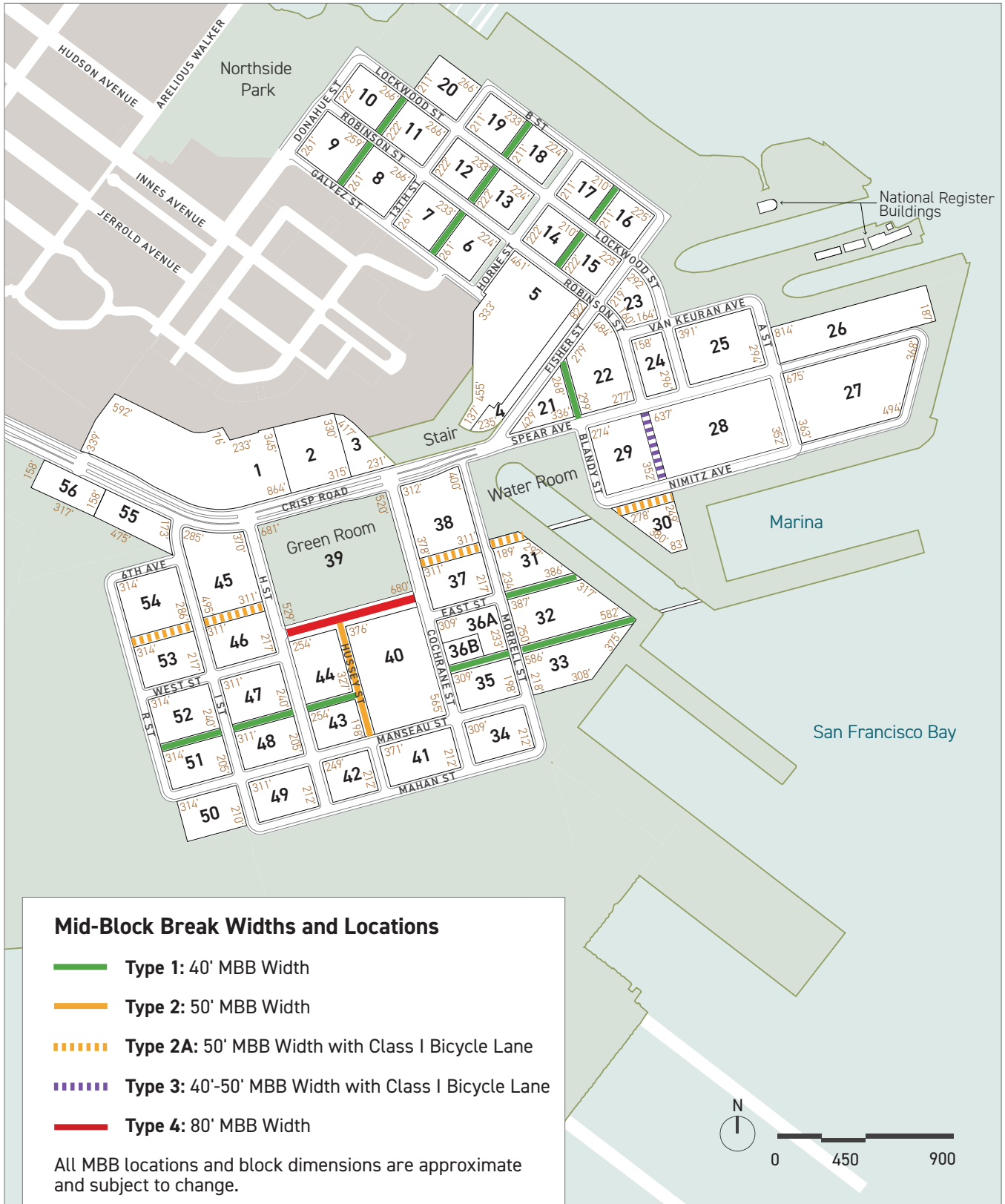

Figure 4.1b: MID-BLOCK BREAK WIDTHS AND LOCATIONS

4.1 Block Sizes and Mid-Block Breaks Cont'd

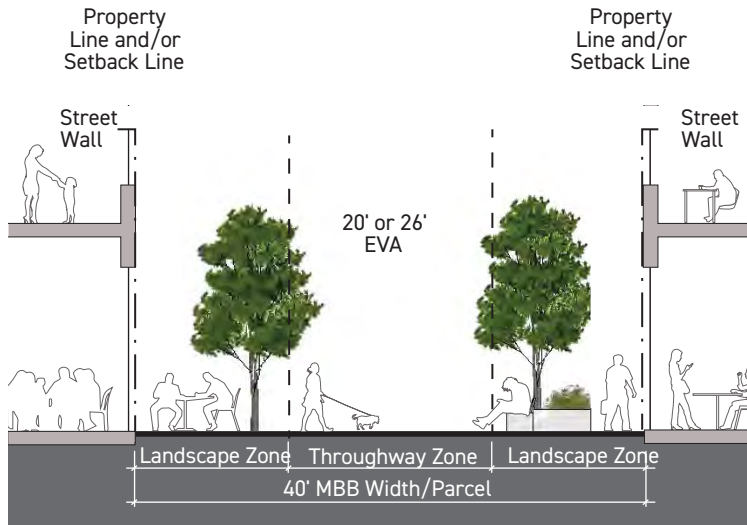

Figure 4.1c: TYPE 1 MID-BLOCK BREAK WIDTH (40') COMMERCIAL

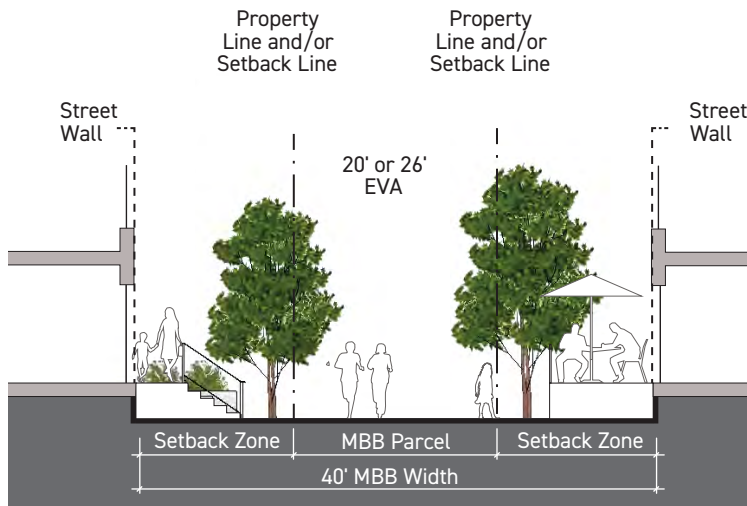

Figure 4.1d: TYPE 1 MID-BLOCK BREAK WIDTH (40') RESIDENTIAL

4.1 Block Sizes and Mid-Block Breaks Cont'd

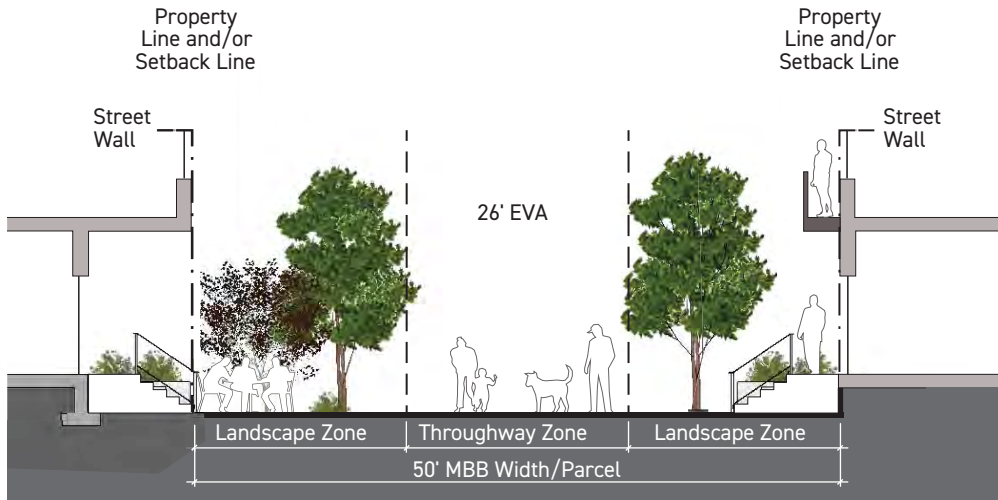

Figure 4.1e: TYPE 2 MID-BLOCK BREAK WIDTH (50')

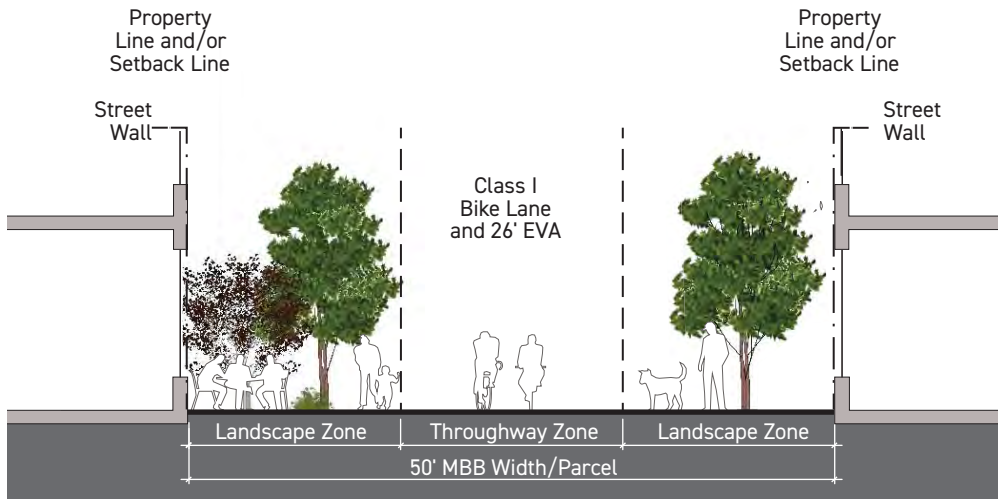

Figure 4.1f: TYPE 2A MID-BLOCK BREAK WIDTH (50') WITH CLASS I BICYCLE LANE

4.1 Block Sizes and Mid-Block Breaks Cont'd

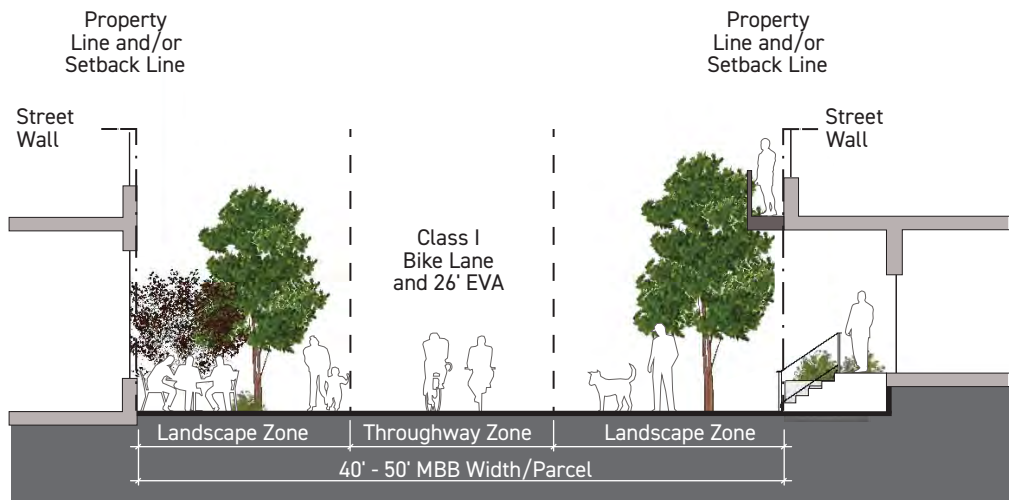

Figure 4.1g: TYPE 3 MID-BLOCK BREAK WIDTH (40' - 50') WITH CLASS I BICYCLE LANE

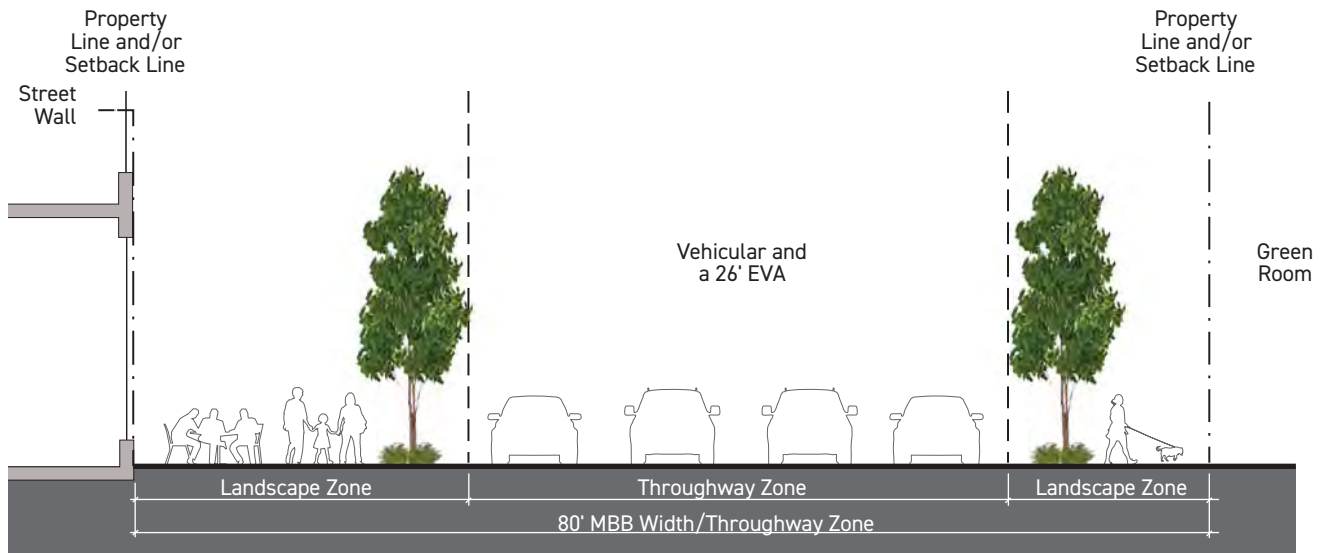

Figure 4.1h: TYPE 4 MID-BLOCK BREAK WIDTH (80')

This page is intentionally left blank.

4.2 Building Setback

- 4.2.1 Building Setback
- 4.2.2 Mid-Block Break Setback

INTENT

Setback requirements provide a minimum and maximum range for Building Face locations and describe a relationship between the building and the public right-of-way for each building location.

Setback Zones 1 and 2 provide an urban Street Wall that frames the public realm and establishes a relationship for buildings fronting streets and public gathering spaces.

Setback Zones 3 through 6 provide spaces for transitions between the public and private realm, including but not limited to landscaping, stoops, and porches. These spaces increase the amount of privacy for ground floor residential units. Larger Setbacks on Robinson and Lockwood Streets, Zones 5 and 6, provide additional area for wider sidewalks, sidewalk seating, landscaping and stoops that will create a sense of arrival into the Shipyard from the neighborhoods to the north on these transportation corridors and bicycle routes.

DEFINITIONS

"Building Face"

A plane of the exterior wall of the building along a public right-of-way, open space, or other publicly accessible space. The term is typically used in the context of its relationship to an adjacent street or public area. Where a minimum Street Wall is required, the Building Face aligns with the maximum Setback.

DEFINITIONS

"Setback"

The required horizontal distance between the Building Face and a property line. See *Figure 4.2a*.

STANDARDS

4.2.1 Building Setback

The Building Face is required to be set back from a property line by a horizontal distance of no less than the minimum Setback and no greater than the maximum Setback as established by *Figure 4.2b*.

Setback requirements do not apply to existing buildings if retained or adaptively reused.

The Setback zone shall be used to create one or more of the following:

- Residential private open spaces (4.26)
- Building entries (4.12)
- Commercial open spaces
- Publicly accessible plazas
- Outdoor seating zones
- Walk-up windows for vending
- Stoops and unit entries (4.12 & 4.26)
- Fences (4.26)
- Stormwater treatment
- Below-grade parking structures (with adequate depth to meet landscape standards for setback area above)
- Screened utility areas (4.14)
- Landscape areas (4.27)
- Or similar
- Refer to Section 4.26 Private Open Space.

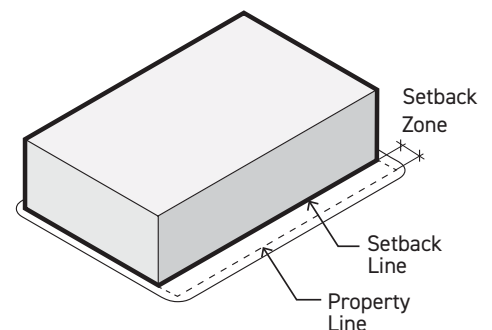

Figure 4.2a: BUILDING SETBACK

Allowable projections into the setback zone are controlled in Standard 4.10.1 Projections.

4.2.2 Mid-Block Break Setback

Setbacks along MBBs are subject to change depending on the final MBB property line location. Setback lines shall be set so that the Street Wall location is located at the MBB Width dimension required in Section 4.1 and *Figure 4.2b*.

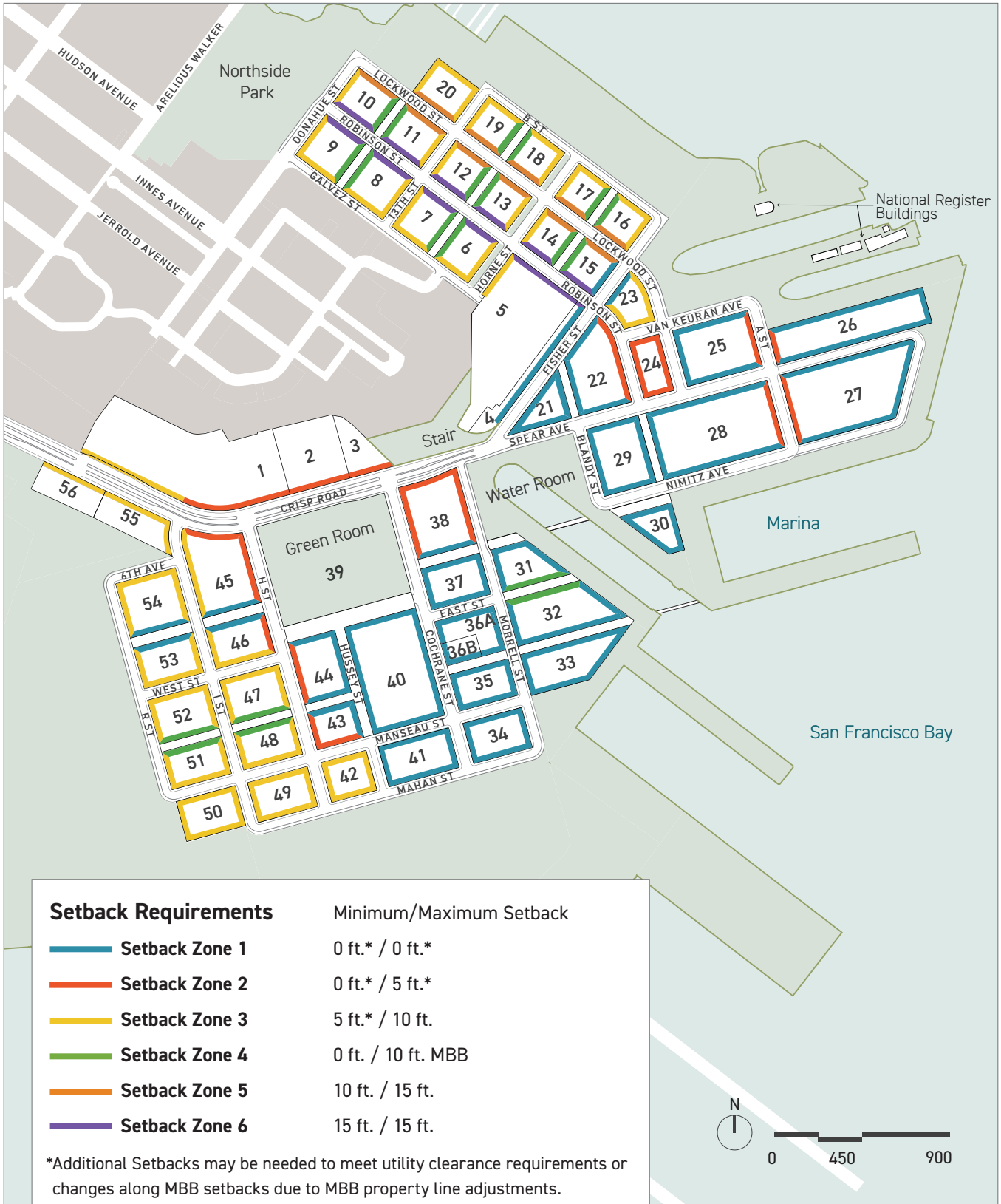

Figure 4.2b: SETBACK REQUIREMENTS



Figure 4.2c: VIEW LOOKING SOUTH

Massing study for illustrative purposes only.



Figure 4.2d: VIEW LOOKING NORTH

Massing study for illustrative purposes only.

4.3 Developable Area Coverage

4.3.1 Developable Area Coverage

INTENT

To regulate the Building Envelope by building lot coverage at various height thresholds in order to ensure that the overall bulk of buildings is at an appropriate scale.

DEFINITIONS

"Developable Area"

All land inside the legal property line, excluding Setbacks.

"Coverage"

The percentage of Floor Plate in relation to the Developable Area that is regulated at various height thresholds, as indicated in *Figure 4.3a* and *Figure 4.3b*.

"Floor Plate"

The Gross Floor Area for an individual floor level of a building.

"Gross Floor Area"

Definition provided in Chapter 6.

STANDARDS

4.3.1 Developable Area Coverage

Developable Area coverage by all habitable and non-habitable building area, including structured parking, is limited as indicated below:

Residential and Residential Mixed-Use Buildings:

Building Height (ft.)	Maximum Allowable Area (Gross sq. ft.)
0-40	100% of Developable Area
41-85	75% of Developable Area
86-120	30,000 sq. ft. maximum (block 45)
121+	12,500 sq. ft. maximum (blocks 15 and 23)

Non-Residential Buildings:

Building Height (ft.)	Maximum Allowable Area (Gross sq. ft.)
0-40	100% of Developable Area
41-95	90% of Developable Area
96-120	80% of Developable Area

For buildings over [120] ft. in height, additional tower design standards apply. Refer to 4.9 Tower Controls.

Shared Parking Structures are not subject to 4.3.1 Developable Area Coverage standard.

Buildings may span multiple parcels between Blocks 1, 2, and 3, Blocks 36A and 36B, and Blocks 55 and 56, respectively.

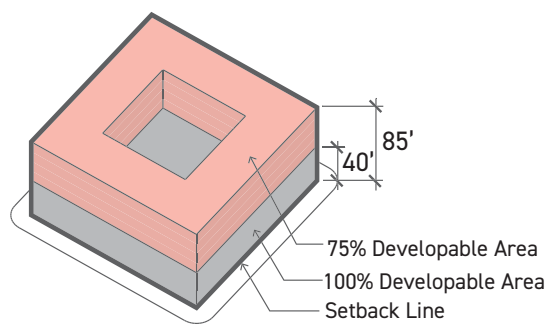

Figure 4.3a: DEVELOPABLE AREA COVERAGE RESIDENTIAL & RESIDENTIAL MIXED-USE BUILDINGS

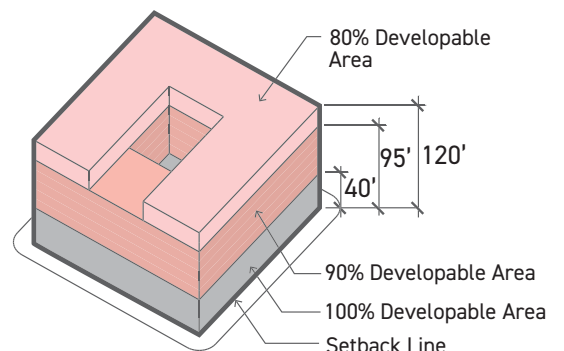

Figure 4.3b: DEVELOPABLE AREA COVERAGE NON-RESIDENTIAL BUILDINGS

4.4 Building Height

4.4.1 Building Height

INTENT

Maximum Building Height, Street Wall, and Stepback requirements establish the building scale in each district. Taller buildings frame urban open spaces and define a skyline that steps down from the hillside towards the waterfront, optimizing views and facilitating the transition to the natural landscape. Stepbacks on the south side of residential and retail focused Mid-Block Breaks allow additional daylight to open space.

DEFINITIONS

"Stepback"

The distance that upper levels of a building may be inset from the primary Building Face.

"Implied Façade"

An Implied Façade is a Building Face that completes the apparent massing through vertical and horizontal architectural elements, such as the roof line, columns, angular shifts, or other elements, that maintain the visual continuity of the Street Wall.

STANDARDS

4.4.1 Building Height

Maximum height requirements are established for all development blocks, as illustrated in *Figure 4.4a*.

Building Height is measured from the highest corner at finished sidewalk grade to the average point on the finished roof in the case of a flat roof, and from the average height of the rise in the case of a pitched or stepped roof, or similarly sculpted roof form. See *Figure 4.4a*.

For parcels adjacent to streets with a slope greater than 5%, Building Height is determined by measuring at the mid-point of the building at the sidewalk grade adjacent to each street-fronting Building Face. The maximum height envelope may extend from one frontage up to a depth of half the distance to the opposite side of the block. Multiple frontages may be used to determine maximum Building Height envelope. See *Figure 4.4b*.

Towers shall be located within the Flexible Tower Zone, as shown in *Figure 4.4c*.

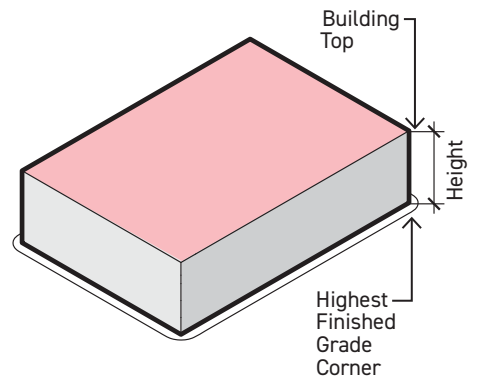

Figure 4.4a: BUILDING HEIGHT

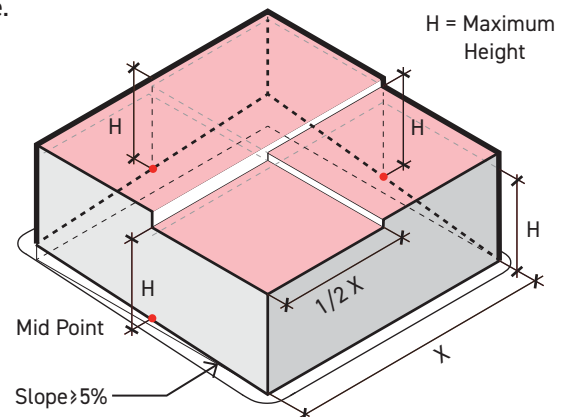

Figure 4.4b: BUILDING HEIGHT ON SLOPE

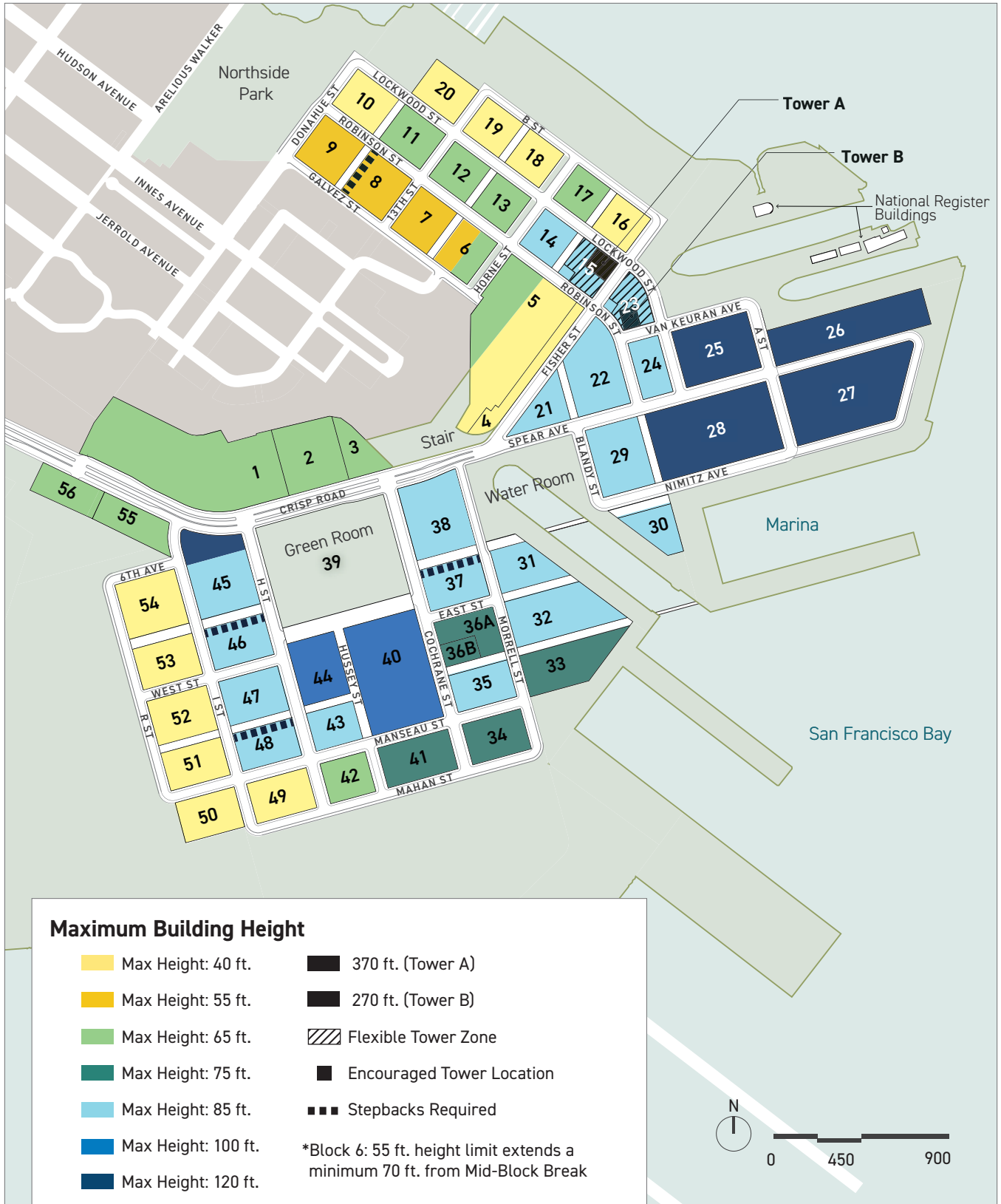

Figure 4.4c: MAXIMUM BUILDING HEIGHT

4.4 Building Height Cont'd

- 4.4.2 Mid-Block Break Building Stepbacks
- 4.4.3 Building Height Exceptions

INTENT

To increase the amount of sunlight that reaches the ground plane of Mid-Block Breaks.

STANDARDS

4.4.2 Mid-Block Break Building Stepbacks

Stepbacks are required at designated locations as indicated in *Figure 4.4c*.

Stepbacks shall occur at a minimum of a 1:1.2 ratio above [45] ft. in building height. The first [70] ft. of building frontage perpendicular to H and Cochrane Streets are exempt. See *Figure 4.4d* and *Figure 4.4e*.

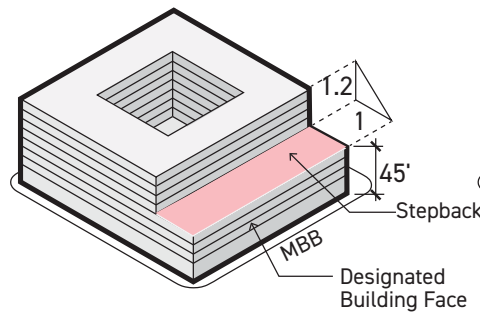

Figure 4.4d: BUILDING STEPBACK

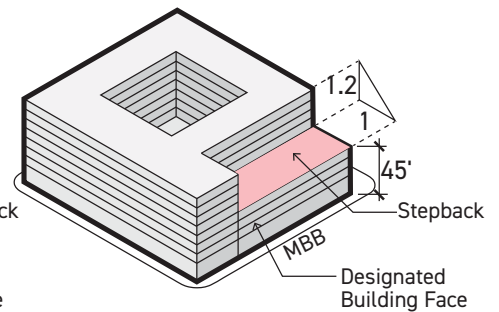

Figure 4.4e: BUILDING STEPBACK

INTENT

To define the type, number, height, and area of elements allowed to exceed the maximum Building Height.

STANDARDS

4.4.3 Building Height Exceptions

The following may extend up to [16] ft. above the maximum Building Height:

- Spires, towers, and other non-habitable architectural features
- Mechanical equipment and appurtenances necessary to the operation or maintenance of the building or structure itself, including chimneys, ventilators, plumbing vent stacks, cooling towers, water tanks, elevator, stair and mechanical penthouses, skylights, window-washing equipment and associated screens
- Sustainable building systems and roof-mounted equipment, such as solar collectors and wind turbines
- Habitable amenity spaces

4.4 Building Height Cont'd

4.4.4 Roof Area Building Height Exception

STANDARDS

Ventilators, vent stacks and mechanical exhaust systems for laboratory uses may extend above the maximum Building Height as necessary to the operation of the building only to the extent required by the corresponding codes. (i.e. building code, health code, etc.).

The screening of Roof-Mounted Equipment shall be stepped back from top of parapet at a ratio of 1:1.2 and no less than ten[10] ft. from the parapet or roof edge. See *Figure 4.4f*.

Parapets may extend up to four[4] ft. above the maximum Building Height.

4.4.4 Roof Area Building Height Exception

The total square footage of enclosed area(s) within rooftop Screening and penthouses shall be no greater than 30% of the total roof area. See *Figure 4.4g*.

Enclosed habitable amenity spaces covering not more than [2,500] sq. ft. of the overall roof area and appurtenant to outdoor amenity spaces may extend up to [16] ft. above the maximum Building Height. See *Figure 4.4h*.

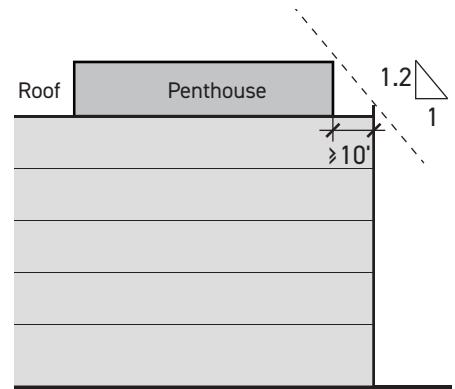

Figure 4.4f: PENTHOUSE STRUCTURE REQUIREMENTS

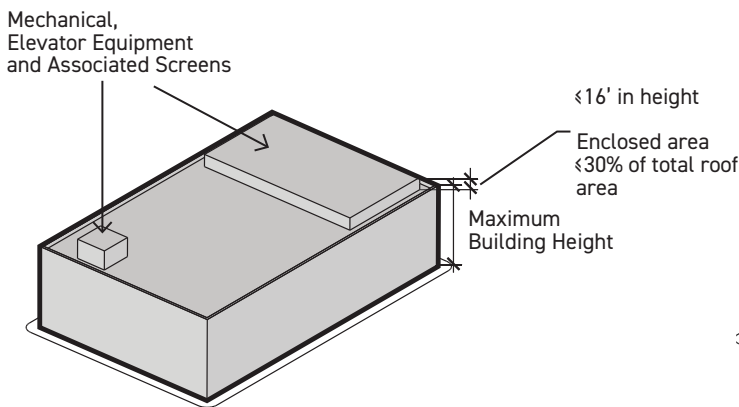

Figure 4.4g: BUILDING HEIGHT EXCEPTION

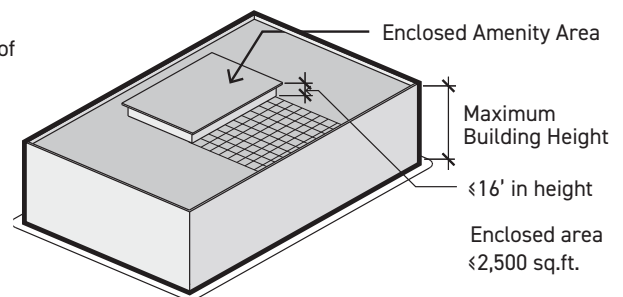

Figure 4.4h: BUILDING HEIGHT EXCEPTIONS ENCLOSED AMENITY AREA

4.4 Building Height Cont'd

- 4.4.5 Street Wall
- 4.4.6 Implied Façade
- 4.4.7 Street Wall Exceptions for Adaptive Reuse
- 4.4.8 Street Wall Exceptions for Recessed Areas

INTENT

To create a strong Building Face that defines the public realm by ensuring a minimum amount of the Building Face is located at the setback line.

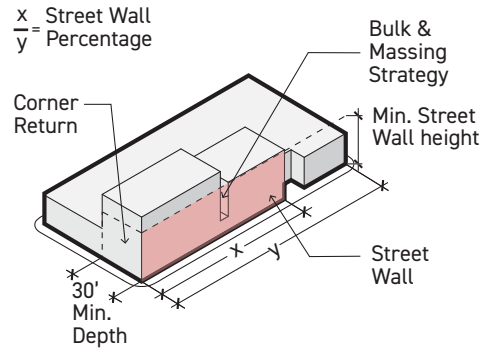

Figure 4.4i: STREET WALL

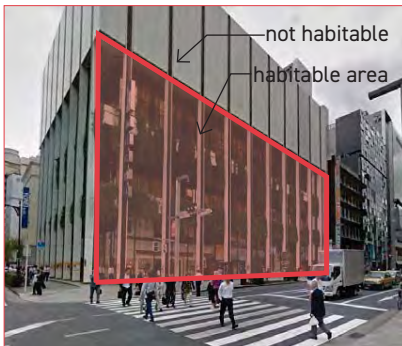

Figure 4.4j: IMPLIED FAÇADE

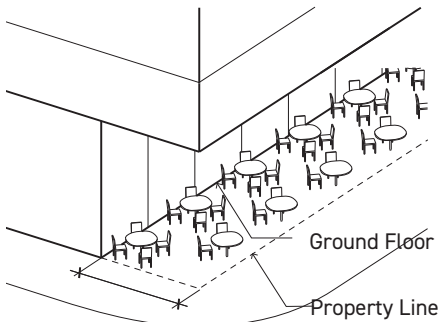

Figure 4.4k: COVERED OUTDOOR SEATING

STANDARDS

4.4.5 Street Wall

Minimum Street Wall heights and Street Wall percentage requirements are established by *Figure 4.4l*.

The Street Wall shall occur within an area bounded by the minimum and maximum Setbacks. The minimum height shall be maintained for a minimum depth of [30] ft. from the Street Wall. In the case of a corner where two different Street Wall heights adjoin, the higher of the two shall prevail for the required depth of [30] ft. Street Wall requirements are calculated independently for each Street Fronting Elevation. Refer to *Figure 4.4i*.

Bulk and Massing and Façade Composition strategies as defined in Section 4.6 and Section 4.7 that are used to meet the Standard requirement shall be counted toward the required Street Wall percentage.

4.4.6 Implied Façade

A required Street Wall may be achieved by an Implied Façade that complies with the height and percentage requirements of the Street Wall Standard. Height of the Street Wall shall be met by habitable building area. Refer to *Figure 4.4j*.

4.4.7 Street Wall Exceptions for Adaptive Reuse

Street Wall requirements do not apply to Adaptive Reuse buildings if retained.

4.4.8 Street Wall Exceptions for Recessed Areas

Street Wall Zones 1-A, 1-B and 2 permit covered outdoor areas at the ground floor, recessed from the Street Wall up to [15] ft. in depth, to allow for patio spaces, entrances, publicly accessible plazas, outdoor seating zones, and/or walk-up windows. The outdoor area shall be no greater than two Stories in height and the Street Wall shall be maintained for the Building above the recessed area. Such an outdoor area shall be immediately accessible by an entrance to the building. Refer to *Figure 4.4k*.

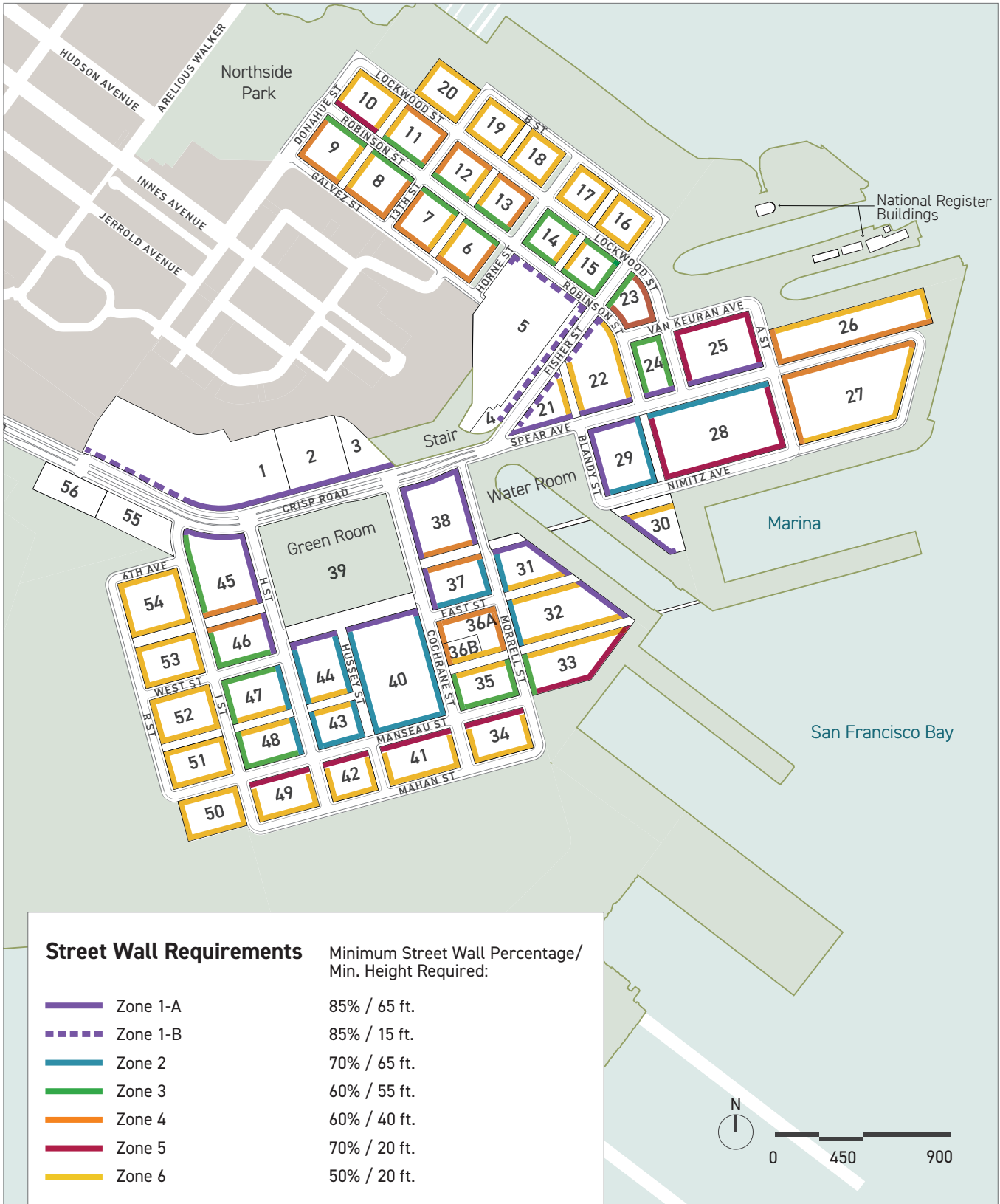

Figure 4.41: STREET WALL REQUIREMENTS



Figure 4.4m: BUILDING SIZES: S, M, L, XL

4.5 Architectural Controls by Building Scale

- 4.5.1 Architectural Controls by Building Scale
- 4.5.2 Maximum Plan Length

INTENT

To determine which controls apply, refer to Flow Chart for "4.5A Architectural Controls by Building Scale Cont'd" (Page 68) which outlines a path to compliance for each building size category. The sections following the Flow Chart describe how Façade Composition, Bulk and Massing, Building and Public Realm Enhancements are regulated and applied.

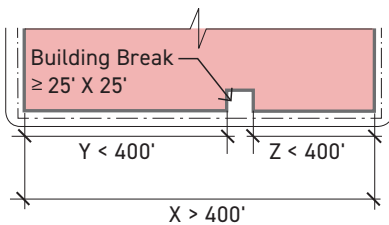

Figure 4.5a: FLOOR PLATE AREA AND MAXIMUM PLAN LENGTH

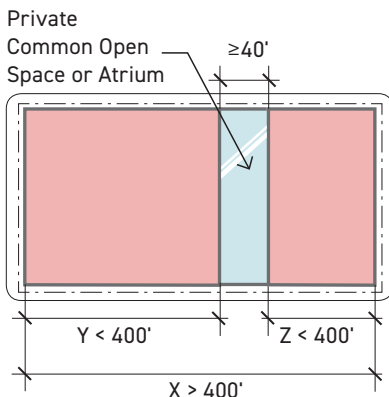

Figure 4.5b: MAXIMUM PLAN LENGTH

DEFINITIONS

"Maximum Plan Length"

The maximum linear dimension of a building measured in plan along a building elevation parallel to the immediately adjacent public right-of-way, MBB, or public open space.

"Street Fronting Elevation"

Building façades facing onto a public right-of-way, MBB, or public open space.

"Small Buildings" (S): Small Buildings include all buildings that have a Maximum Plan Length that is less than [150] ft. in length.

"Medium Buildings" (M): Medium Buildings include all buildings that have a Maximum Plan Length greater than [150] ft. in length along any facade and have a maximum Floor Plate less than [70,000] sq. ft.

"Large Buildings" (L): Large Buildings include all buildings with a maximum Floor Plate between [70,000] and [100,000] sq. ft.

"Extra Large Buildings" (XL): Extra Large Buildings include all buildings with a maximum Floor Plate greater than [100,000] sq. ft.

STANDARDS

4.5.1 Architectural Controls by Building Scale

Buildings have been grouped in four[4] categories: Small (S), Medium (M), Large (L) and Extra Large (XL). All buildings shall meet the Façade Composition Standards. In addition to Façade Composition Standards, Medium, Large and Extra Large buildings shall follow Bulk and Massing Standards and Building and Public Realm Enhancement Standards (see Flow Chart on page 68).

4.5.2 Maximum Plan Length

No Street Fronting Elevation shall have a Maximum Plan Length greater than [400] ft. without one[1] of the following: See *Figure 4.5a*.

- A building break that is at minimum [25] ft. by [25] ft. in dimension and extends from roof plane to sidewalk grade.
- A private common open space or Atrium that connects through to the opposite side of the block. Open space may include Skyways. Open space shall be at minimum [40] ft. wide in each dimension with a view to the sky. See *Figure 4.5b*.

4.5A Architectural Controls by Building Scale Cont'd

FLOW CHART FOR ARCHITECTURAL CONTROLS

All Buildings shall meet the Façade Composition Standards. In addition to Façade Composition Standards, Medium, Large and Extra Large Buildings shall follow Bulk and Massing Standards and Building and Public Realm Enhancement Standards.

FC

4.6.1 Façade Composition

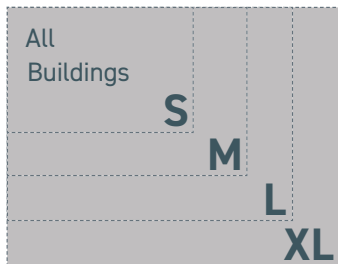

Apply two[2] Façade Compositions:
See Page 70

FC1 Façade Modulation

FC2 Façade Articulation

FC3 Fenestration

FC4 Material/Color

BM

4.7.1 Bulk and Massing

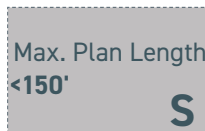

No Bulk and Massing Approaches or Building and Public Realm Enhancement Measures Required



Apply one[1] Bulk and Massing Approach:
See Page 81

BM1 Significant Breaks

BM2 Upper Floor Stepbacks

BM3 Façade Variation

BE/PE

4.8.1 Building and Public Realm Enhancements

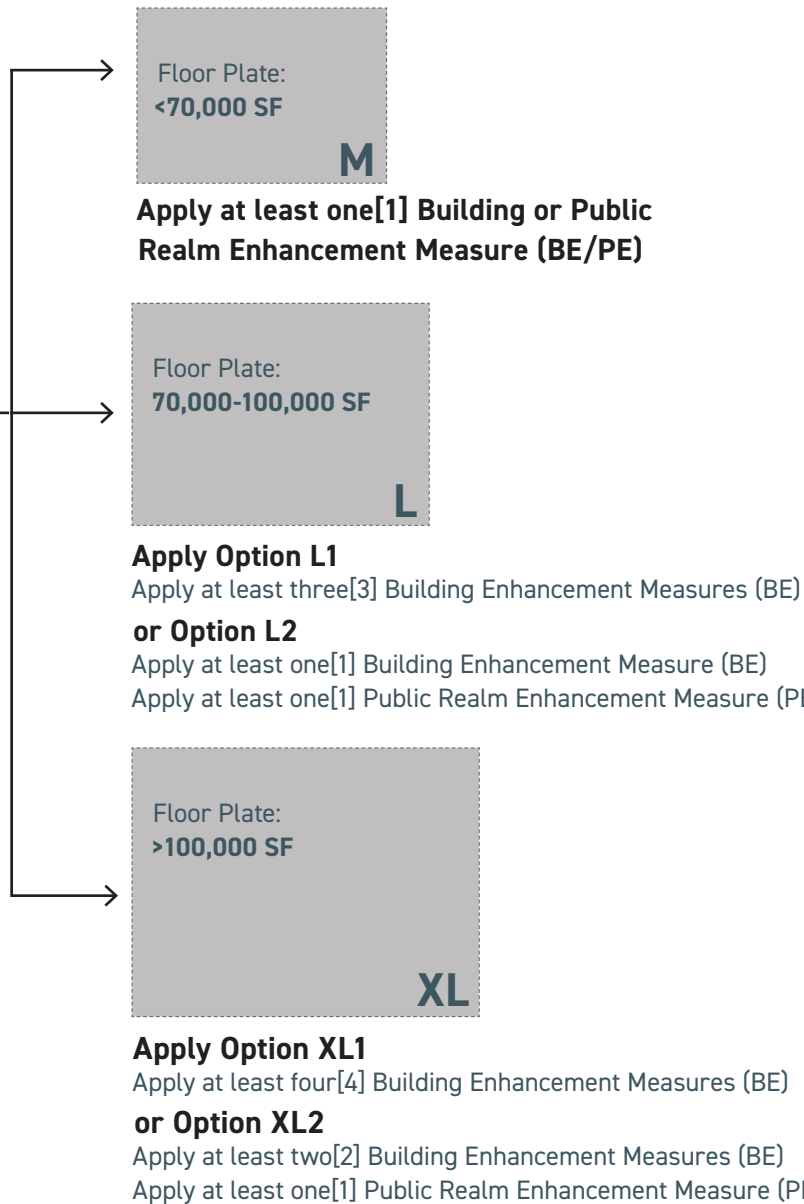

Building Enhancement Measures (BE):

See Page 88

- BE1** Apply one[1] Additional Bulk and Massing Approach
- BE2** Orient Private Courtyards and/or Atria onto a Public Right-of-Way or MBB
- BE3** Visual and Physical Access to Interior Courtyard/Atrium
- BE4** 24/7 Access to Open Space
- BE5** Reduction in Floor Plate Area of Upper Floors
- BE6** Expressive Entrance
- BE7** Increased Transparency
- BE8** Distinct Corner Architecture Feature
- BE9** Roof Expression
- BE10** Additional Active Entries
- BE11** Additional Ground Floor Activation

Public Realm Enhancement Measures (PE):

- PE1** Public Access through the Building
- PE2** Public Access through Open Space Connections

4.6 **FC** Façade Composition

4.6.1 Façade Composition

INTENT

To create character, distinction, and visual interest on the facades of all buildings.

DEFINITIONS

"Façade Composition"

Large scale facade geometry and smaller scale facade tectonics, including material selection and detailing.

"Street Fronting Elevation"

Building façades facing onto a public right-of-way, MBB, or public open space.

"Variations in Façade Composition"

Variations in Façade Composition create visual interest and avoid monotony. This can be achieved by using either two[2] different Façade Compositions or by using two [2] distinctly different designs of the same Façade Composition. In case of the latter, the two [2] designs must be recognizably different in expression.

STANDARDS

4.6.1 Façade Composition

Street Fronting Elevations of all buildings shall have a minimum of two [2] Façade Compositions. The same application shall not fulfill the requirement for more than one Façade Composition.

Choose two[2] Façade Compositions:

FC1	Façade Modulation	FC3	Fenestration
FC2	Façade Articulation	FC4	Material/Color



Figure 4.6a: BUILDING A

Example: Building A uses the following two[2] Façade Compositions:
See *Figure 4.6a*.

FC1 Façade Modulation:
Angular Shift and Horizontal Shift

FC3 Fenestration:
Punched Windows



Figure 4.6b: BUILDING B

Example: Building B uses the following two[2] Façade Compositions.
See *Figure 4.6b*.

FC2 Façade Articulation:
Sun Shading Devices

FC3 Fenestration:
Boxed Windows and Curtain Wall

4.6 **FC** Façade Composition Cont'd

4.6.2 Block to Block Variation

INTENT

To provide architectural variety and visual interest from Block to Block by demonstrating distinction between opposing Block faces and between Block faces adjacent to each other along a street, MBB, or other open space.

STANDARDS

4.6.2 Block to Block Variation

Buildings shall be distinct from one[1] Block Façade to adjacent Block Façade by incorporating variations in at least two[2] Façade Compositions. See *Figure 4.6c*.

Vary façade with two[2] Compositions:

- | | | | |
|------------|---------------------|------------|----------------|
| FC1 | Façade Modulation | FC3 | Fenestration |
| FC2 | Façade Articulation | FC4 | Material/Color |

Example: If Block A and Block B both use the same Façade Modulation (FC1) and Fenestration (FC3), then Block A and B shall be a distinct variation from one another in their Material/Color (FC4) and Façade Articulation (FC2). See *Figure 4.6c* and *Figure 4.6d*.

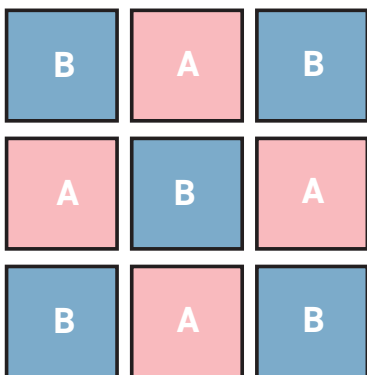

Figure 4.6c: BLOCK TO BLOCK VARIATION (ADJACENT BLOCK FAÇADES SHALL BE DISTINCT FROM BLOCK A)

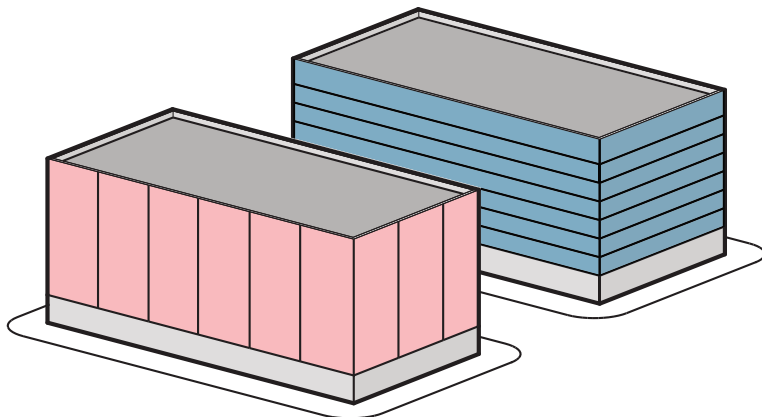

Figure 4.6d: BLOCK A (VERTICAL ARTICULATION AND MATERIAL COLOR) BLOCK B (HORIZONTAL ARTICULATION AND MATERIAL COLOR)

4.6 **FC** Façade Composition Cont'd

FC1 Façade Modulation Strategies

INTENT

To shape building massing and provide visual interest, scale, and rhythm to a building and/or building Façade.

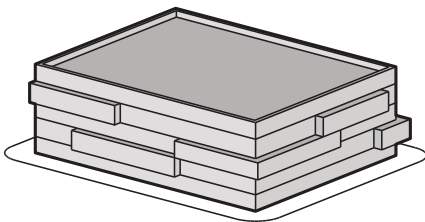
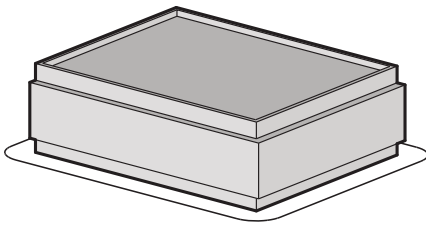

Figure 4.6e: HORIZONTAL SHIFT

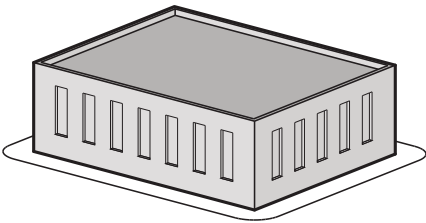

Figure 4.6f: VERTICAL SHIFT

APPLICATION

FC1 Façade Modulation

Façade Modulations shall include plan shifts in the Façades, expressions of building structure, Building Projections, and other strategies that provide visual interest and depth that is recognizable from a distance. Plan shifts and framing shall be a minimum of two [2] ft. in depth. The extent and scale of Façade Modulations shall be proportional to and in keeping with the scale of the entire building. Double skins and structural expressions that are character-defining features of the façade have no minimum depth requirements.

Changes in the Façade plane made for the application of the Façade Modulation may be used to create an Implied Façade.

MODULATION STRATEGIES

The following are a non-exhaustive list of Façade Modulation strategies:

"Horizontal Shift"

The Façade is defined by horizontal subdivisions which project forward or push back from each other. The horizontal subdivisions may, but need not be, determined by the location of the building floor slabs.

See *Figure 4.6e*.

"Vertical Shift"

The Façade is subdivided into "bays" that protrude or recess from a predetermined datum. These bays may be expressive of a programmatic or structural characteristic of the building. See *Figure 4.6f*.

4.6 FC Façade Composition Cont'd

FC1 Façade Modulation Strategies



1. & 2. Horizontal Shift Example
3. 4. & 5. Vertical Shift Example



4.6 **FC** Façade Composition Cont'd

FC1 Façade Modulation

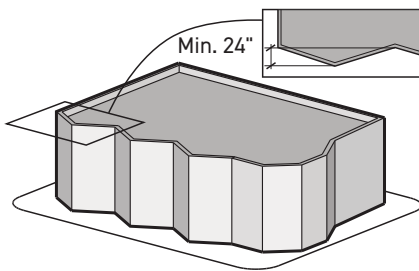

Figure 4.6g: ANGULAR SHIFT

MODULATION STRATEGIES

"Angular Shift"

A series of sloped or faceted surfaces along the façade. Angular shifts shall be minimum [24] in. in depth. See *Figure 4.6g*.

"Framing"

Elements of a Façade can be identified as modules through the use of a frame or framing element. A frame can be a continuous protrusion which follows some perimeter at the façade scale. See *Figure 4.6h*.

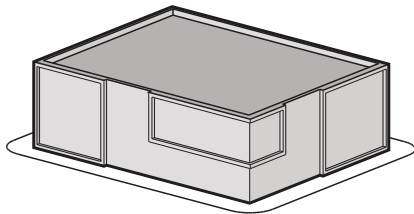

Figure 4.6h: FRAMING

"Double Skin"

A Façade system created by a second enclosure, typically lighter and slightly translucent or perforated, outboard of the main exterior Building Envelope. A double skin may have operable components and is meant to add depth and intricacy by way of light and shadows along the Façade. See *Figure 4.6i*.

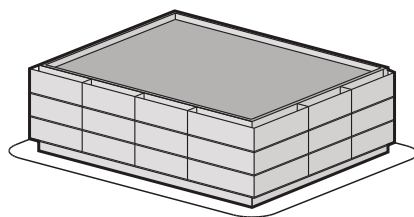

Figure 4.6i: DOUBLE SKIN

"Structural Expression"

Actual structural elements such as beams, columns, cross-bracing, or fastenings can naturally break up a building's Façade if made visible along a building's exterior. See *Figure 4.6j*.

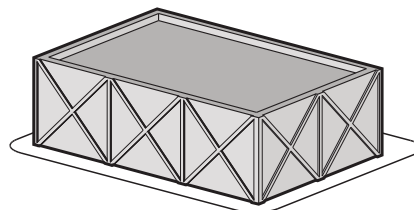

Figure 4.6j: STRUCTURAL EXPRESSION

4.6 FC Façade Composition Cont'd

FC1 Façade Modulation



- 1. Double Skin Example
- 2. Angular Shift Example
- 3. Structural Expression Example
- 4. Angular Shift Example
- 5. Framing Example

4.6 FC Façade Composition Cont'd

FC2 Façade Articulation

INTENT

To create a cohesive Façade system. Façade Articulation strategies are intended to create visual interest, texture, and shadows, through the tectonics, materiality, and craft of the facade.

DEFINITION

"Façade Articulation"

Expressions of material properties, craft, treatment, pattern and/or assembly that create visible shadows and/or texture across the Building Façade.

APPLICATION

FC2 Façade Articulation

Articulation can either emphasize distinct components of a Façade or create smooth, continuous transitions between elements to emphasize the "whole." A non-exhaustive list of strategies are listed below:

Articulation Strategies:

- Vertical Recesses
- Horizontal Extensions
- Architectural Fins
- Louvers
- Shading Devices
- Cornices
- Punched Openings
- Window Reveals
- Screening Devices
- Balconies
- Or Similar

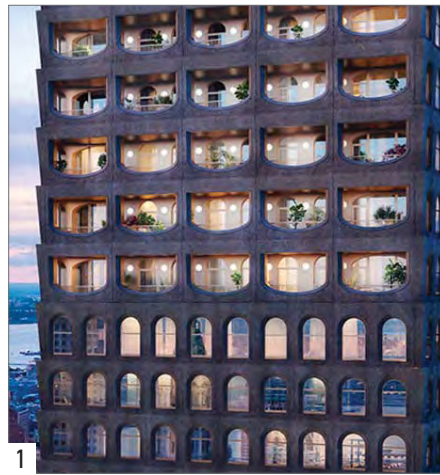

1

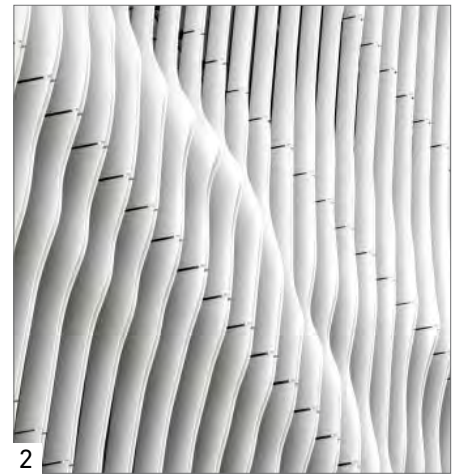

2



3

1. Punched Openings Example
2. Architectural Fins Example
3. Balcony Example

4.6 FC Façade Composition Cont'd

FC2 Façade Articulation



1. Vertical Recesses and Punched Openings Example
2. Architectural Fins and Louvers Example
3. Punched Openings Example
4. Balcony, Extensions and Recesses Example
5. Punched Openings Example
6. Shading Devices and Cornice Example

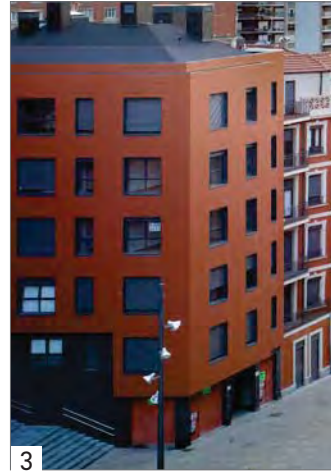
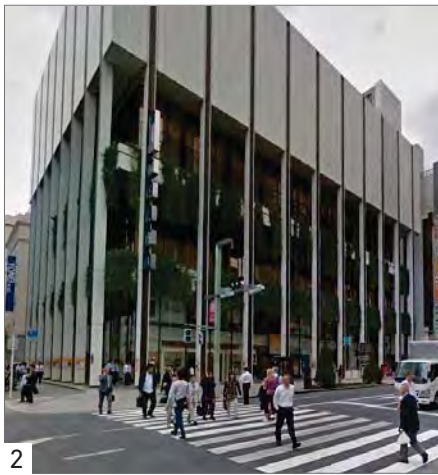

4.6 **FC** Façade Composition Cont'd

FC3 Fenestration

INTENT

Building Fenestration strategies are Façade composition elements that contribute to the character of a building and the feel of the urban environment. These strategies modulate Daylight and potential for natural ventilation in buildings.

DEFINITION

"Fenestration"

The design, construction, or presence of openings in a building. Fenestration includes windows, doors, louvers, vents, wall panels, skylights, storefronts, curtain walls, and sloped systems.

APPLICATION

FC3 Fenestration

Fenestration strategies include a variety of techniques to bring Daylight into a building and help define the character of a building. Fenestration strategies include shape, size, pattern, rhythm, and location of façade apertures.

Successful fenestration strategies stand out as a central component or feature of a building's enclosure. Such strategies strengthen the expression of the building's architectural character. A non-exhaustive list of strategies are listed below:

Fenestration Strategies:

- Glass Curtain Wall
- Punched Window
- Window Wall
- Double Skin
- Boxed Window
- Bay Window
- Glazed Atrium at the façade
- Or Similar

4.6 FC Façade Composition Cont'd

FC3 Fenestration

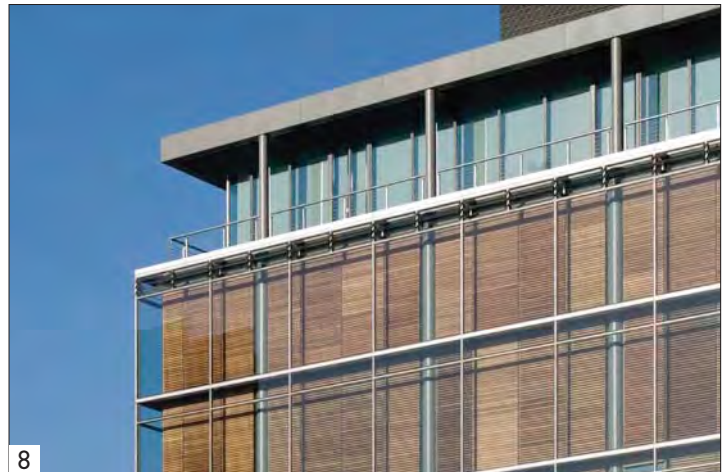

- 1. Punched Windows Example
- 2. Punched Windows + Curtain Wall Example
- 3. Punched Windows Example
- 4. Curtain Wall Example
- 5. Curtain Wall and Atrium Example
- 6. Curtain Wall with Boxed Windows Example
- 7. Window Wall Example
- 8. Double Skin Example

4.6 FC Façade Composition Cont'd

FC4 Material/Color

INTENT

The intentional application of Material/Color creates a defined architectural vocabulary that provides visual interest and contributes to the urban character. The materiality, patina, texture, color and craftsmanship respond to the unique quality of the district.

DEFINITION

"Material/Color"

The application of materials, color, shades and texture for a building when used as a quality- and character-defining features of the Façade.

For the purposes of meeting standard 4.6.1 Façade Composition, Variations in Material/Color strategies shall include a change in color and a change in material or a change in application of material such as change in pattern and/or texture. Color differences alone do not qualify as a variation.

APPLICATION

FC4 Material/Color

Material and color may be used as a volumetric application, as an organizing element, or to create contrast between different building elements. Refer to 4.6 Façade Materials. A non-exhaustive list of strategies are as follows:

Material/Color Strategies:

- Volumetric Application
- Organizing Feature
- Structural
- Tectonics
- Character Defining Feature



2



3

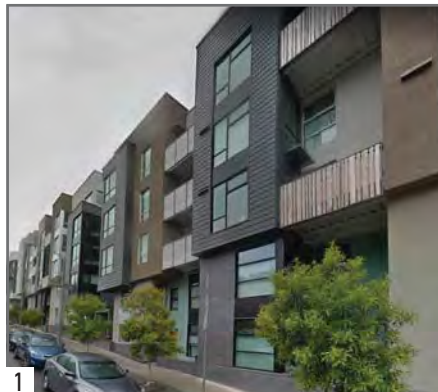

1



4

1. Materials and Colors as a Volumetric Application Example
2. Metal used as Monolithic Application Example
3. Brick as Organizing Element Example
4. Character-Defining Façade Composition Example

4.7 **BM** Bulk and Massing

4.7.1 Bulk and Massing Approach

INTENT

To facilitate a varied urban form and shape building scale and geometry. To reflect neighborhood character and provide a human-scale pedestrian realm as well as an attractive skyline when viewed from afar.

DEFINITIONS

"Bulk and Massing"

Bulk and Massing regulations are the combination of controls (lot size, lot coverage, open space, yards, heights and setbacks) that determine the maximum Building Envelope.

"Apparent Face"

The unbroken plane of a Building within a single Façade composition.

"Primary Façade Plane"

The plane that incorporates the primary Façade of a Street Fronting Elevation.

STANDARDS

4.7.1 Bulk and Massing Approach

Medium, Large, and Extra Large Buildings shall use at least one[1] of the following approaches for breaking up the Bulk and Massing of Building Façades greater than [150] ft. in length. Buildings are not required to use the same Bulk and Massing Approach for every Façade.

Choose at least one[1] approach:

- BM1** Significant Breaks
- BM2** Upper Floor Stepbacks
- BM3** Façade Variation

4.7 **BM** Bulk and Massing Cont'd

BM1 Significant Breaks

INTENT

To reduce the Bulk and Massing of buildings by the introduction of vertical breaks within the Façade Plane. Such breaks may articulate building mass or provide rhythm to the Façade.

APPLICATION

BM1 Significant Breaks

An Apparent Face on a Street Fronting Elevation shall be no greater than [150] ft. in length without a Significant Break in the Primary Façade Plane.

Significant Breaks shall be in the form of vertical interruptions within the Primary Façade Plane that are at least as wide and deep as 10% of the longest adjoining Apparent Building Face. (Example: If the longest Apparent Face is [100] ft. in length, the Significant Break shall be at least ten[10] ft. wide and ten[10] ft. deep; if the longest Apparent Face is [150] ft. in length, the Significant Break shall be at least [15] ft. wide and [15] ft. deep.)

Significant Breaks shall extend from the roof plane to a building height of [25] ft. or less from the sidewalk grade. The break may extend to grade.

Significant Breaks may occur at any rhythm or length of a Primary Façade Plane. The minimum Significant Break dimension is two[2] ft. by two[2] ft.

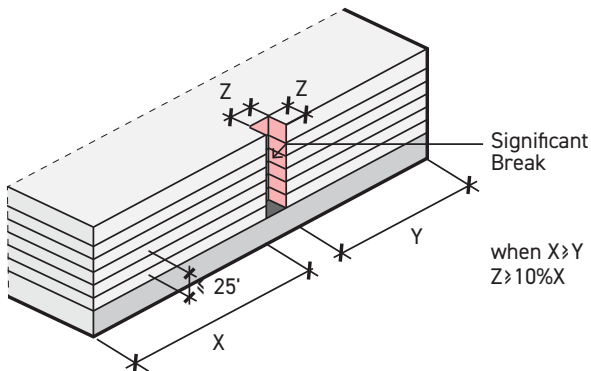

Figure 4.7a: SIGNIFICANT BREAKS A

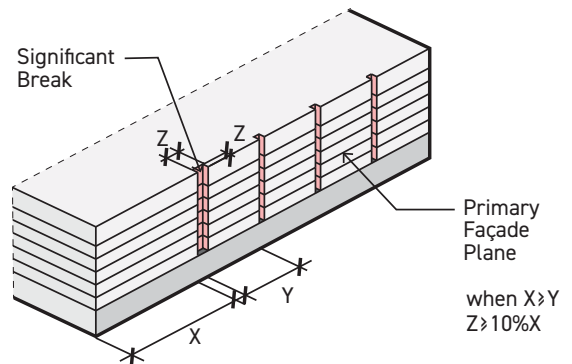

Figure 4.7b: SIGNIFICANT BREAKS B

4.7 **BM** Bulk and Massing Cont'd

BM1 Significant Breaks



1. & 2. Significant Break

4.7 **BM** Bulk and Massing Cont'd

BM2 Upper Floor Stepbacks

INTENT

To reduce the Bulk and Massing of buildings by stepping back the upper floors and thereby reducing the perceived height of the building, and to provide more sunlight to the public realm while reinforcing the character and providing visual interest to the building and roof plane.

APPLICATION

BM2 Upper Floor Stepbacks

At a minimum, the topmost floor of the building shall step back from the Primary Façade Plane.

The Stepback shall be an average minimum of ten[10] ft. from the Primary Façade Plane.

A minimum of 60% of the façade length shall step back a minimum of ten[10] ft. from the Primary Façade Plane.

Upper floor(s) shall Stepback at the following heights:

STEPBACK REQUIREMENTS BY BUILDING HEIGHT	
Building Height	Stepback Height
≤85 ft.	Top floor or lower
85 - 120 ft.	86 ft. or lower

Figure 4.7c: STEPBACK REQUIREMENTS BY BUILDING HEIGHT

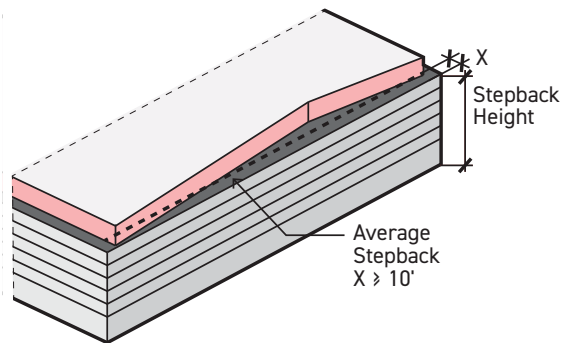

Figure 4.7d: AVERAGE MINIMUM STEPBACK

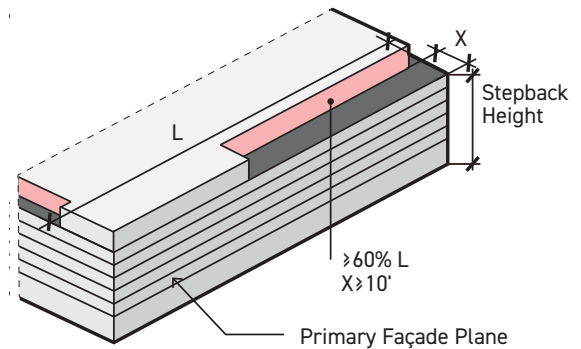

Figure 4.7e: MINIMUM LENGTH OF STEPBACK

4.7 **BM** Bulk and Massing Cont'd

BM2 Upper Floor Stepbacks



1

1. Upper Floor Building Stepback

4.7 **BM** Bulk and Massing Cont'd

BM3 Façade Variation

INTENT

To reduce the appearance of building bulk by incorporating significant changes within the Primary Façade's composition.

DEFINITION

"Variation"

A significant change or difference in form, proportion, position, condition, quantity, level or other compositional characteristic. Variation describes adjacent elements comprising both similar and different attributes that are recognizable as related.

APPLICATION

BM3 Façade Variation

Façades on all Street Fronting Elevations greater than [150] ft. in length shall be broken down into smaller Façade segments, or Apparent Faces, through significant changes in Façade Composition. The significant change may be a Horizontal Variation, a Vertical Variation, or a combination of Horizontal and Vertical Variations, including an angular Variation in the façade.

A significant change in Façade Composition shall include a Variation

in at least two[2] of the following Façade Compositions: Modulation, Articulation, Fenestration, and/or Material/Color.

FV1 Horizontal Variations

At least two[2] Horizontal Variations shall occur for any façade that exceeds [150] ft. in length representing a building base, middle and top. Or at least one[1] Horizontal Variations with a Vertical Variation in at least one[1] of the horizontal façade compositions. See *Figure 4.7f* and *Figure 4.7g*.

FV2 Vertical Variations

A Variation in Façade Composition shall occur at a minimum [150] ft. or less of façade plan length. The adjacent apparent face shall be at least 10% as wide as the longest adjoining apparent face. Variations may occur at any rhythm or cadence. See *Figure 4.7h* and *Figure 4.7i*.

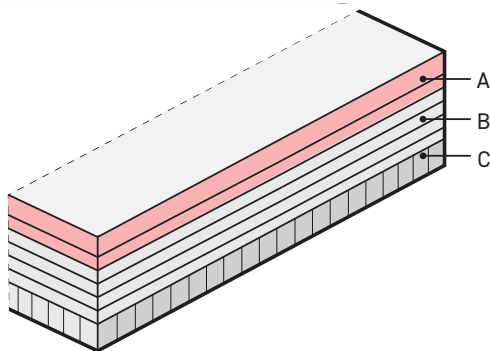

Figure 4.7f: EXAMPLE OF FV1 HORIZONTAL VARIATION A

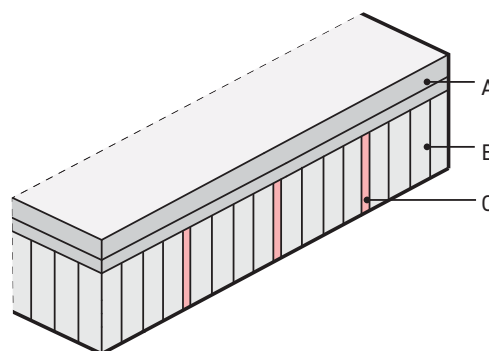

Figure 4.7g: EXAMPLE OF FV1 HORIZONTAL VARIATION B

4.7 **BM** Bulk and Massing Cont'd

BM3 Façade Variation



- 1. Façade Variation FV1 Horizontal
- 2. Façade Variation FV2 Vertical

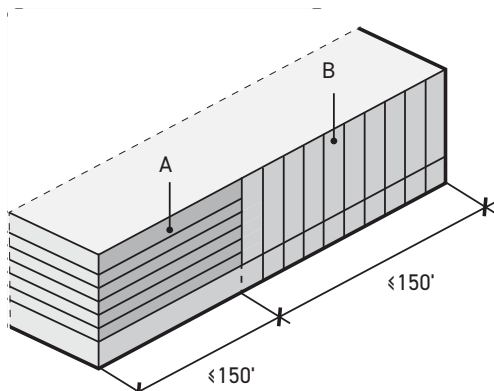

Figure 4.7h: EXAMPLE OF FV2 VERTICAL VARIATION A

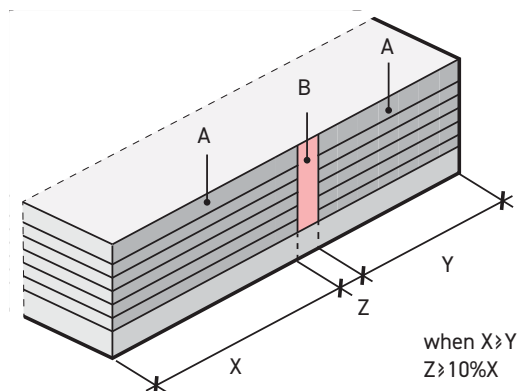

Figure 4.7i: EXAMPLE OF FV2 VERTICAL VARIATION B

4.8 **BE/PE** Building and Public Realm Enhancements

4.8.1 Building and Public Realm Enhancement Measures for M, L, XL Buildings

INTENT

To break down the scale of buildings and to create sufficient relationships between the interior of the building and the Public Realm through enhancement measures that shape architectural and spatial features.

DEFINITIONS

"Building Enhancement"

An architectural design feature that improves the character of the building and adds interest to the design.

"Public Realm Enhancement"

An expansion of the pedestrian network that provides public access through private developments.

STANDARDS

4.8.1 Building and Public Realm Enhancement Measures for M, L, XL Buildings

Medium (M), Large (L) and Extra Large (XL) buildings shall apply additional enhancement measures as outlined below. The required number of enhancement measures apply to and shall be visible from each Street Fronting Elevation. Any combination of building and Public Realm Enhancement Measures may be applied to a building so that the minimum required number of measures are visible from each Street Fronting Elevation. (Example: a Distinct Corner would apply to two[2] Street Fronting Elevations; an Expressive Entrance would only apply to each Street Fronting Elevation from which it is visible.)

Medium Buildings (M)

Medium Buildings shall apply at least one[1] additional Building Enhancement Measures and/or Public Realm Enhancement Measure.

Large Buildings (L)

Large Buildings shall apply at least three[3] additional Building Enhancement Measures or shall apply at least one[1] additional Building Enhancement Measure and at least one[1] Public Realm Enhancement Measure.

Extra Large Buildings (XL)

Extra Large Buildings shall apply at least four[4] additional Building Enhancement Measures or shall apply at least two[2] additional Building Enhancement Measures and at least one[1] Public Realm Enhancement Measure.

4.8 BE/PE Building and Public Realm Enhancements

- BE** Building Enhancement Measures
- PE** Public Realm Enhancement Measures

Cont'd

BUILDING ENHANCEMENT MEASURES (BM)

BE1 Apply One[1] Additional Bulk/Massing Approach
 Apply one[1] additional approach from the 4.7.1 Bulk and Massing Approach. See *Figure 4.8a*.

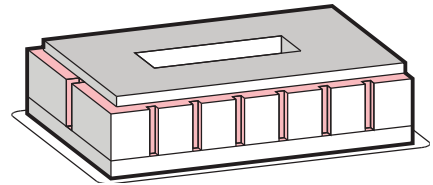

Figure 4.8a: BE1 - APPLY ONE ADDITIONAL BULK/MASSING CONTROL (EXAMPLE: SIGNIFICANT BREAKS + UPPER FLOOR STEPBACK EXAMPLE)

BE2A Orient Private Courtyards and/or Atria Onto a Public ROW or MBB (Per Street Fronting Elevation)
 A minimum of one[1] private courtyard and/or Atrium shall face onto a public right-of-way or Mid-Block Break. Courtyards and Atria shall be of a minimum dimension of [40] ft. x [40] ft. Lowest level of courtyards and/or Atria shall be no higher than [25] ft. from sidewalk grade. See *Figure 4.8b*.

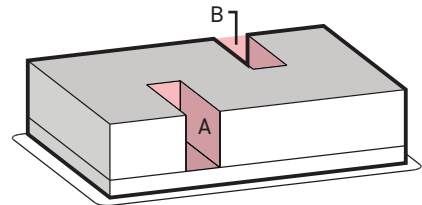

Figure 4.8b:
 BE2A - COURTYARD/TRIA A OR B
 BE2B - COURTYARD/TRIA A + B

BE2B Orient Private Courtyards and/or Atria Onto a Public ROW or MBB (Multiple Street Fronting Elevations)
 A minimum of two[2] open-air courtyards shall face onto two[2] public rights-of-way or Mid-Block Breaks or HPS2 open spaces. The two[2] open-air courtyard area dimensions shall be a total of 20 percent of the longest Street Fronting Elevation. Courtyards and Atria shall be of a minimum dimension of [40] ft. x [40] ft. All Street Fronting Elevations receive credit for applying this measure. See *Figure 4.8b*.

BE3 Provide Visual and Physical Access to Interior Courtyard and/or Atrium
 Provide Visual and Physical Access through an open-air portal entry into an interior courtyard or direct access into an Atrium from a public right-of-way, open space or Mid-Block Break. Visual access into the building shall be at minimum [25] ft. wide and a minimum two[2] stories in height. The lowest level of courtyards and/or Atria shall be no higher than [25] ft. from sidewalk grade. The physical access may be public or private. See *Figure 4.8c*.

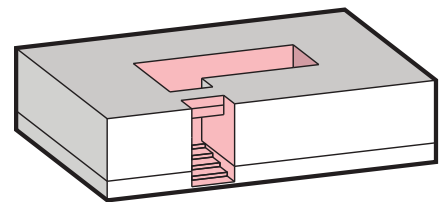

Figure 4.8c: BE3 - PROVIDE VISUAL AND PHYSICAL ACCESS TO INTERIOR COURTYARD AND/ OR ATRIUM

BE4 Permanently Open Public Access to Open Space
 Provide ground floor open space with no fencing or barriers that is permanently open and accessible to the public. Ground floor publicly accessible open space shall have a minimum dimension of [40] ft. by [40] ft. See *Figure 4.8d*.

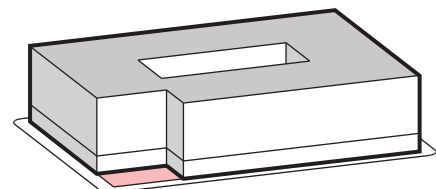

Figure 4.8d: BE4 - PERMANENTLY PUBLIC ACCESS TO OPEN SPACE

4.8 BE/PE Building and Public Realm Enhancements

- BE** Building Enhancement Measures
- PE** Public Realm Enhancement Measures

Cont'd

BE5 Reduction in Floor Plate Area of Upper Floors

Provide an additional 30% reduction of Floor Plate at the upper levels as follows: for buildings [75] ft. and taller, reduce the upper two levels by 30% of Floor Plate relative to the floor beneath; for buildings less than [75] ft. tall, reduce the top Floor Plate by 30% relative to the floor beneath. Each Street Fronting Elevation receives credit for applying this measure. See *Figure 4.8e*.

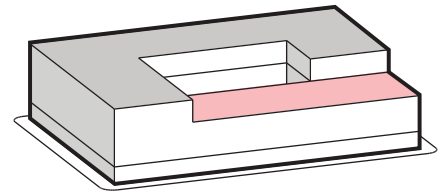

Figure 4.8e: BE5 - REDUCTION IN FLOOR PLATE AREA OF UPPER FLOORS

BE6 Expressive Entrance

Provide an Expressive Entrance to enhance identity and visual access into the building. For residential buildings, the Expressive Entrance shall be at minimum [20] ft. wide along the façade and a minimum two[2] stories in height. For commercial and mixed-use buildings, the Expressive Entrance shall be at minimum [35] ft. wide along the façade and a minimum two[2] stories in height. See *Figure 4.8f*.

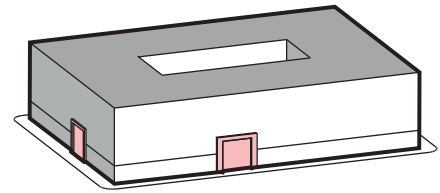

Figure 4.8f: BE6 - EXPRESSIVE ENTRANCE

BE7 Increased Transparency

For commercial buildings, provide a minimum 60% Transparency for the entire Street Fronting Elevation. For residential buildings, provide a minimum 35% Transparency for the entire Street Fronting Elevation. Areas counted in meeting this requirement must be comprised of Transparent Glazing. See *Figure 4.8g*.

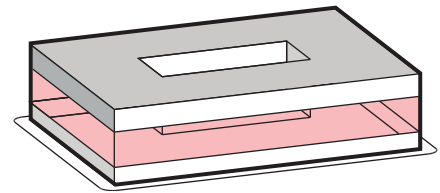

Figure 4.8g: BE7 - INCREASED TRANSPARENCY

BE8 Distinct Corner Architectural Feature

Provide a distinct architectural feature of special character and design that accentuates a change or interruption in the architectural language of the building. The corner element shall be at least [25] ft. in width and change in height by a minimum of five[5] ft. above or below the adjacent roof line and/or be integrated with a Roof Expression. See *Figure 4.8h*.

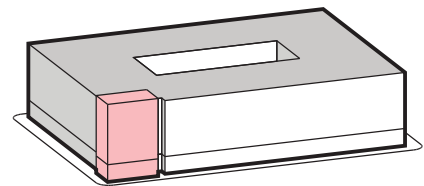

Figure 4.8h: BE8 - DISTINCT CORNER ARCHITECTURAL FEATURE

4.8 BE/PE Building and Public Realm Enhancements

- BE** Building Enhancement Measures
- PE** Public Realm Enhancement Measures

Cont'd

BE9 Roof Expression

A roof expression shall be observed as a recognizable shape or profile against the sky as visible from eye-level in the adjacent pedestrian realm. It may accentuate a change or interruption in the architectural language of the building. See *Figure 4.8i*.

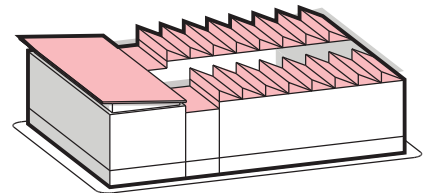

Figure 4.8i: BE9 - ROOF EXPRESSION

BE10 Additional Active Entrances

For Ground Floor Zones 1 and 2, provide a total of two[2] Active Entrances per [75] ft. of Street Fronting Elevation. For Zone 3, provide a total of two[2] Active Entrances per [100] ft. of Street Fronting Elevation. Refer to 4.11 Ground Floor Activation. See *Figure 4.8j*.

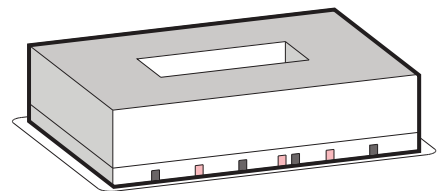

Figure 4.8j: BE10 - ADDITIONAL ACTIVE ENTRANCES

BE11 Additional Ground Floor Activation

Increase Ground Floor Activation from that required by designated Ground-Floor Active Use Zone to meet the percentage of Ground Floor Activation required by the next higher Ground-Floor Active Use Zone (see Ground-Floor Activation Plan on Page 95). Example: Building in Ground-Floor Active Use Zone 2 increases Ground Floor Activation to meet the requirements of Ground-Floor Active Use Zone 1.

PUBLIC REALM ENHANCEMENT MEASURES

PE1 Public Access through the Building

Provide at-grade public access during business hours extending through to the opposite side of the block. Public access shall provide access between a public right-of-way, Mid-Block Break or HPS2 open space to another public right-of-way, Mid-Block Break or HPS2 open space. This pass-through shall be at a minimum two[2] stories in unobstructed height and [25] ft. in width. Above the lowest two[2] stories, public access pass-through may be crossed by catwalks, Skyway connections, habitable spaces, and/or floor plates. All Street Fronting Elevations receive credit for applying this measure. See *Figure 4.8k*.

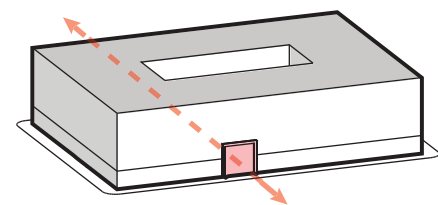

Figure 4.8k: PE1 - PUBLIC ACCESS THROUGH THE BUILDING

PE2 Public Access through Open Space Connection

Provide at-grade public access during business hours in the form of a private common open space that connects through to the opposite side of the block. Open space shall be open to the sky at a minimum of [40] ft. in width. Skyways may be located over open spaces. All Street Fronting Elevations receive credit for applying this measure. See *Figure 4.8l*.

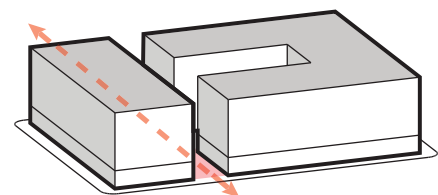

Figure 4.8l: PE2 - PUBLIC ACCESS THROUGH OPEN SPACE CONNECTION

4.9 Tower Controls

- 4.9.1 Tower Locations
- 4.9.2 Tower Floor Aspect Ratio
- 4.9.3 Tower Height Variation
- 4.9.4 Tower Massing and Articulation
- 4.9.5 Tower Mechanical Equipment
- 4.9.6 Tower Mechanical Equipment Screening

INTENT

To provide standards particular to Towers. Where Towers are designed to meet the ground, Tower standards apply to the entire Tower, all the way to the ground. Where Tower designs are integrated with a podium on the same block, all other standards apply to the portion of the block that is not within the footprint of the tower above.

DEFINITIONS

"Floor Aspect Ratio"

The ratio that controls the proportions of the Floor Plate. Floor Aspect Ratio compares the shorter plan dimension of the Floor Plate to the longer plan dimension. A square Floor Plate would have an aspect ratio of 1:1.

STANDARDS

4.9.1 Tower Locations

Towers shall be located within the flexible tower zones and Towers "A" and "B" shall be a minimum [160] ft. apart. See *Figure 4.9a*.

4.9.2 Tower Floor Aspect Ratio

To maintain the slender appearance of Towers, the Floor Plates shall not exceed [12,500] sq. ft. and the Floor Aspect Ratio shall range between 1:1.2 and 1:1.6. A rectangular Floor Plate without notches is an acceptable form. See *Figure 4.9b*.

4.9.3 Tower Height Variation

The Towers on Blocks 15 and 33 shall differ in height from one another by at least 33%.

4.9.4 Tower Massing and Articulation

Towers shall be stepped, sculpted, tapered, and/or have FC2 - Façade Articulation.

If stepped, the building shall have a 33% reduction in floor area for the top 10% of floors. If sculpted, tapered, or articulated, the maximum floor area for the Tower above [85] ft. in height shall be no greater than the equivalent maximum floor area if there was a 33% reduction in floor area for the top 10% of floors.

4.9.5 Tower Mechanical Equipment

Mechanical Equipment shall not exceed the Maximum Building Height of the Tower by more than 10%. The mechanical equipment shall not occupy a floor plate greater than [10,625] sq. ft. (85% of the allowable floor plate size).

4.9.6 Tower Mechanical Equipment Screening

Mechanical equipment shall be screened from view to its full vertical extent.

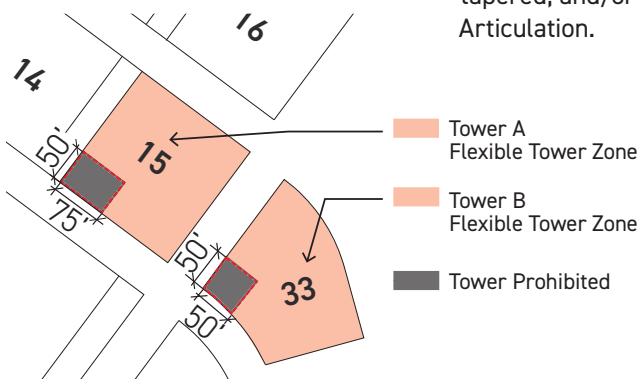

Figure 4.9a: FLEXIBLE TOWER ZONE

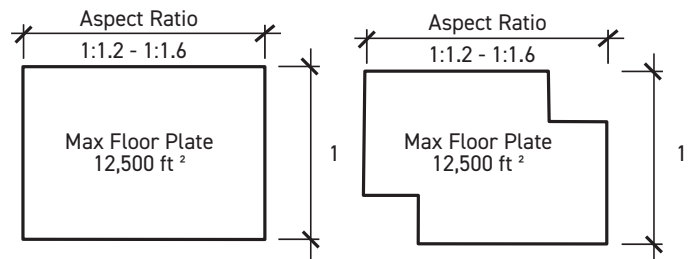

Figure 4.9b: TOWER FLOOR PLATE

4.9 Tower Controls Cont'd

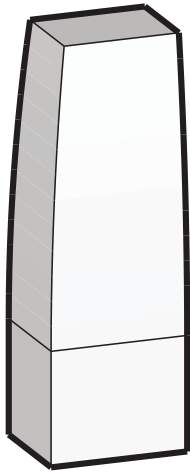

Figure 4.9c: TAPERED TOWER EXAMPLE

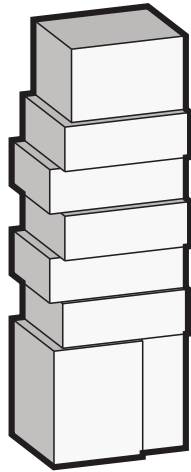

Figure 4.9d: SCULPTED TOWER EXAMPLE

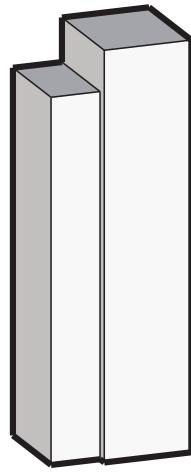

Figure 4.9e: STEPPED TOWER EXAMPLE

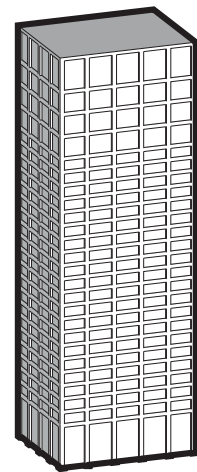
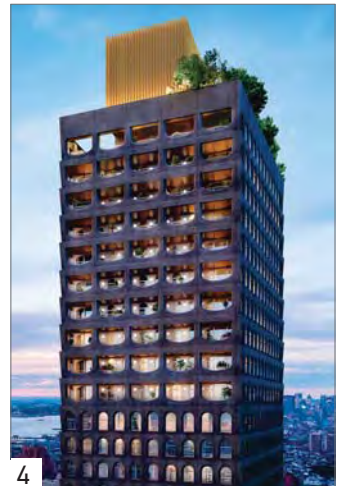

Figure 4.9f: FAÇADE ARTICULATION TOWER EXAMPLE



1. Tapered Tower Example
2. Sculpted Tower Example
3. Stepped Tower Example
4. Facade Articulation Tower Example

4.10 Projections

- 4.10.1 Projections
- 4.10.2 Habitable Projections
- 4.10.3 Non-Habitable Projections
- 4.10.4 Other Projections
- 4.10.5 Projection Exemptions
- 4.10.6 Maximum Projection Area

INTENT

To provide visual interest and architectural creativity.

DEFINITIONS

"Habitable Projection"

A portion of the building enclosed by walls and a roof which extends beyond the property or minimum Setback line. Examples include a bay window, a corner element, or a regularly occurring Façade modulation that extends through some or all floors of a building.

"Non-Habitable Projection"

A portion of the building not enclosed by walls and a roof which extends beyond the property or minimum Setback line. Examples include usable balconies or outdoor decks, structural projections, screens, Awnings, fins, or similar architectural elements.

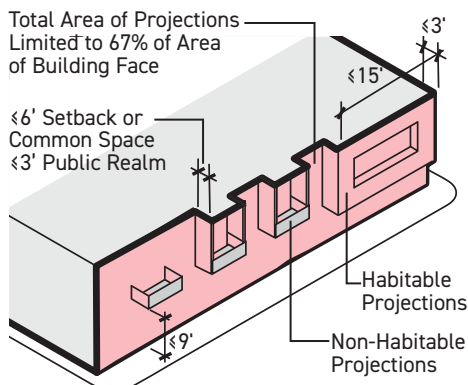

Figure 4.10a: PROJECTIONS

STANDARDS

4.10.1 Projections

Projections into the Setback area, right-of-way, Mid-Block Break, or public open space are allowed as follows: See *Figure 4.10a*.

4.10.2 Habitable Projections

A habitable space may project three[3] ft. beyond the Building Face, either into a Setback zone or into the public realm. No individual Habitable Projection may exceed [15] ft. in length. All Projections shall have a minimum vertical clearance of nine[9] ft. above the sidewalk. All Projections shall have a minimum separation distance equal to the depth of the Projection.

4.10.3 Non-Habitable Projections

Non-habitable spaces may extend into Setbacks or private open spaces by no more than six[6] ft. into a Setback or private open spaces or in no case over three[3] ft. into the public realm. No individual Non-Habitable Projection may exceed [15] ft. in length. All Projections shall have a minimum vertical clearance of nine[9] ft. above the sidewalk. All Projections shall have a minimum separation distance equal to the depth of the Projection.

4.10.4 Other Projections

Decorative elements such as belt courses, cornices, sills and eaves that extend not more than [30] in. beyond the building face are exempt from this standard.

4.10.5 Projection Exemptions

Decks, patios and steps at the first floor of occupancy that extend to the property line are exempt from this standard.

Fences and railings up to [42] in. in height are exempt from this standard.

Retail signs, canopies and awnings that do not extend more than five[5] ft. beyond the property line with a minimum vertical clearance above the sidewalk of at least nine[9] ft. are exempt from this standard.

4.10.6 Maximum Projection Area

The cumulative total of all types of projections shall not exceed 67% of the Building Face.

4.11 Ground Floor Activation

INTENT

To create an interesting and inviting pedestrian environment and to enhance neighborhood safety and security by encouraging "eyes on the street." The goal of Ground Floor design is to employ architectural methods to increase visibility and foster activity while also deterring unwanted behaviors.

DEFINITIONS

"Active Uses"

Ground Floor land uses that create an interesting and inviting pedestrian environment that enhance neighborhood safety and security by encouraging, "eyes on the street," visibility and vibrancy.

"Active Entrance"

A building entrance into an active Ground Floor use. Entrance may be public or private. Single uses may have multiple active Ground Floor entries.

"Active Frontage"

Building Façade length lined with Active Uses

Type "A" Active Uses:

- Retail
- Restaurants
- Community uses
- Commercial lobbies
- Entertainment uses
- Or similar

Type "B" Active Uses:

- Commercial services
- Medical offices
- Storefront offices
- Commercial and residential lobbies
- Parking Structure lobbies
- Professional services
- On-site sales and leasing offices
- Childcare facilities
- Private common open spaces or atria
- Maker spaces
- Art-related uses such as publicly accessible gallery spaces
- Amenity spaces
- Co-working spaces
- Open offices
- Conference rooms
- Cafeterias
- Break rooms
- Bicycle Workshop
- Bicycle Parking*
- Or similar

Type "C" Active Uses:

- Residential lobbies
- Residential amenity spaces
- Stoop porches
- Terraces
- Ground Floor dwelling units with direct, individual pedestrian access to a public right-of-way, MBB or public open space (Ground Floor studio units, embedded one bedrooms and senior housing units are not required to have direct access)

Non-Active Uses:

- Vehicle parking
- Parking and loading entrances
- Emergency egress
- Mechanical and utility rooms
- Exit stairwells and service shafts
- Or similar

4.11 Ground Floor Activation Cont'd

*Bicycle Parking may be considered an Active Use if it is consistent with the Guidelines below:

- Bicycle Parking rooms shall have circulation space along the entire street-facing perimeter.
- Direct and secure access shall be provided from the sidewalk or pedestrian easement.
- Bicycle Parking shall be visually interesting and can use graphics, art, color, etc. to meet this requirement.
- Bicycle Parking Façade shall provide direct visual access into the bicycle parking room. Individual Bicycle Parking stalls or racks can be screened from the Public Realm for security.
- Bicycle Parking shall be well lit but light trespass and glare shall be kept to a minimum.

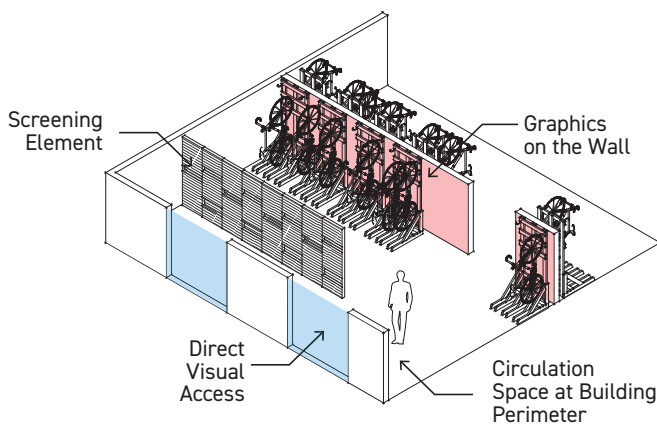

Figure 4.11a: BICYCLE PARKING



1. & 2. Active Bicycle Storage Examples

4.11 Ground Floor Activation Cont'd

- 4.11.1 Zone 1 and 2 Active Entrances
- 4.11.2 Zone 3 Active Entrances
- 4.11.3 Active Ground Floor Depth
- 4.11.4 Ground Floor Height
- 4.11.5 Waterfront Activation
- 4.11.6 Guidelines for Ground Floor Residential Design

INTENT

To create an interesting and inviting pedestrian environment through increased activity in and out of Ground Floor Active Uses and to maintain an adequate size and scale of Active Use spaces.

STANDARDS

4.11.1 Zone 1 and 2 Active Entrances

Each Street Facing Elevation in Zones 1 and 2 shall have a minimum average of one[1] Active Entrances per [75] ft. or less of Active Frontage. See *Figure 4.11b*.

4.11.2 Zone 3 Active Entrances

Each Street Facing Elevation in Zone 3 shall have a minimum average of one[1] Active Entrances per [100] ft. or less of Active Frontage. See *Figure 4.11b*.

4.11.3 Active Ground Floor Depth

The minimum depth of ground floor active uses for all non-residential buildings, not including service corridors, is [20] ft.; for residential buildings the minimum is ten[10] ft.

4.11.4 Ground Floor Height

Type "A" and Type "B" active uses shall have a minimum ground floor to floor height of [15] ft.

4.11.5 Waterfront Activation

A minimum [3,500] sq. ft. of publicly accessible Type "A" use shall be provided along the waterfront façades of Blocks 26, 27 or 28. The Type "A" Active Use may be located in one or multiple spaces and/or blocks.

4.11.6 Guidelines for Ground Floor Residential Design

Ground floor residential Active Uses shall follow the San Francisco "Guidelines for Ground Floor Residential Design."

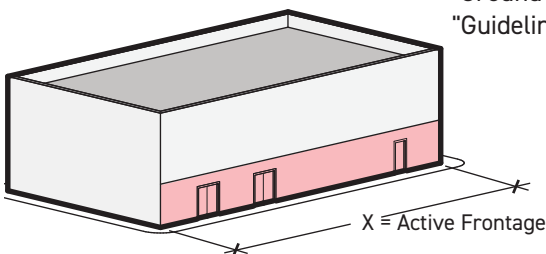

$$\frac{X}{150} * [2] = \text{Entries Req. for Zone 1 \& 2}$$

$$\frac{X}{100} * [1] = \text{Entries Req. for Zone 3}$$

Figure 4.11b: ACTIVE ENTRANCES CALCULATION

4.11 Ground Floor Activation Cont'd

- 4.11.7 Ground Floor Activation
- 4.11.8 Shared Parking Structures Activation

INTENT

To maintain a minimum amount of active ground floor frontages on all public right-of-ways, Mid-Block Breaks, and public open spaces.

DEFINITIONS

"Shared Parking Structure"

A separate structure providing Accessory Parking to off-site lawful non-Accessory uses and not attached to or included within a building containing a lawful non-Accessory use.

STANDARDS

4.11.7 Ground Floor Activation

The percentage of Ground Floor Activation is calculated by taking the total combined length of all Active Frontages around the perimeter of a Block and dividing by the overall length of all Façades within that same Block. See *Figure 4.11c*.

At Zones 1, 2 and 3, each Street Facing Elevation shall have a minimum of 50% Active Uses.

Zone 1

Buildings shall contain a minimum 85% of Type "A" Active Frontages uses on the Ground Floor.

Zone 2 and 3

Buildings shall contain a minimum 75% of Active Frontages on the Ground Floor. Active uses shall consist of those established in *Figure 4.11d*.

Zone 4

Shared Parking Structures in Zone 4 shall comply with 4.11.8 Shared Parking Structures Activation. If buildings in Zone 4 are built as primarily commercial or residential uses, Ground Floor activation rules for Zones 2 and 3 shall apply.

4.11.8 Shared Parking Structures Activation

All corners of Shared Parking Structures shall include Type "A", "B" or "C" Active Uses for a minimum of [20] ft. by [20] ft. dimension. In addition, Shared Parking Structures shall include a minimum of 25% of Type "A", "B" or "C" Active Uses on the ground floor.

If two[2] Shared Parking Structures face one another, at least one[1] of the two facing façades shall include at minimum 75% of active uses on the ground floor.

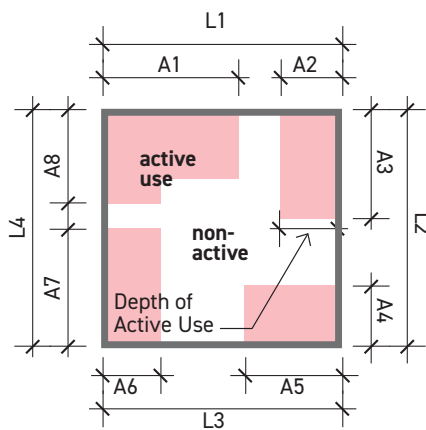

$$\frac{(A1 + A2 + A3 + A4 + A5 + A6 + A7 + A8)}{(L1 + L2 + L3 + L4)} = \% \text{ Active}$$

Figure 4.11c: ACTIVE USE PERCENTAGE CALCULATION



Figure 4.11d: GROUND FLOOR ACTIVATION REQUIREMENTS

4.11 Ground Floor Activation Cont'd

- 4.11.9 Ground Floor Active Use Transparency
- 4.11.10 Ground Floor Active Use Glass and Glazing

INTENT

To provide visual access to the Ground Floor Building interior, enhance Public Realm safety by providing "eyes on the street", to provide lighter color architectural materials at the ground floor and to minimize blank walls.

DEFINITIONS

"Transparent Glazing"

Glass and glazing systems that are designed to provide visual access and light transmittance.

"Active Use Transparency"

The surface area of Transparent Glazing as a proportion of the surface area of the Ground Floor Active Frontage.

STANDARDS

4.11.9 Ground Floor Active Use Transparency

Active Frontage shall be fenestrated with transparent windows and doorways and allow visibility to the inside of the Building to meet the minimum percentage for each Active Use type as follows and as illustrated in *Figure 4.11e*.

4.11.10 Ground Floor Active Use Glass and Glazing

Ground Floor and retail storefront glass shall be maximum 15% reflective, visible light transmittance greater than 80%, and without tint or coloration in the glass substrate. Non-storefront glazing may have up to 50% reflectivity.

Transparent Glazing shall be used to allow a constant relationship between the inside space and the public realm. Dark tinted and/or opaque glazing is not permitted.

Type "A" and "B":

Active Frontage shall incorporate no less than 60% of transparent glazing in the vertical zone between four[4] ft. and eight[8] ft. in height from finished Ground Floor.

Type "C":

Active Frontage for Residential units shall incorporate no less than 30% of Transparent Glazing in the vertical zone between four[4] ft. and eight[8] ft. in height from the finished ground floor.

Lobby and amenity spaces shall be 60% transparency glazing in the vertical zone between four[4] ft. and eight[8] ft. in height from the finished Ground Floor.

$$\frac{\text{Area of Transparent Façade(sq. ft.) between 4 ft. and 8 ft. in Height}}{\text{Length of Active Frontage(ft) * 4 ft.}} = \% \text{ of Transparency}$$

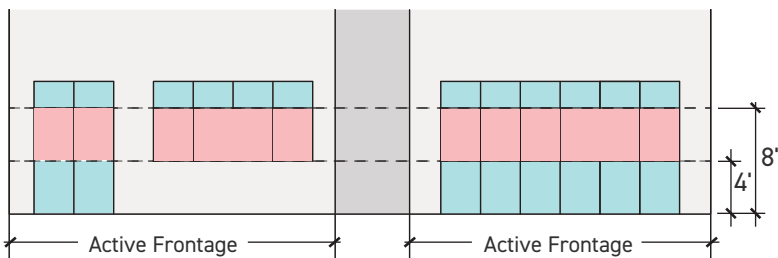

Figure 4.11e: GROUND FLOOR TRANSPARENCY CALCULATION

1 & 2. Ground Floor Transparency Examples



4.11 Ground Floor Activation Cont'd

This table summarizes the ground floor design controls of the four different Ground Floor Activation zones. Each of the controls listed here is defined in Section 4.11 and 4.17.

Ground Floor Frontage	Zone 1	Zone 2	Zone 3	Zone 4
4.11 Active Uses	Type "A"	Type "A" or "B"	Type "A","B" or "C"	Type "A","B" or "C"
4.11.1 & 4.11.2 Active Entrances	Each Street Facing Elevation in Zones 1 and 2 shall have a minimum average of one[1] active entrances per [75] ft. or less of Façade length		Each Street Facing Elevation in Zone 3 shall have a minimum average of one[1] active entrances per [100] ft. or less of Façade length	N/A
4.11.6 Ground Floor Activation	Buildings shall contain a minimum 85% of Type "A" Active Frontages uses on the Ground Floor	Buildings shall contain a minimum 75% of Active Frontages on the Ground Floor Each Street Facing Elevation shall have a minimum 50% of Active Uses		N/A
4.11.7 Shared Parking Structure Activation	N/A	N/A	N/A	All corners of Shared Parking Structures shall include Type "A", "B" or "C" Active Uses for a minimum of [20] ft. by [20] ft. dimension. In addition, Shared Parking Structures shall include a minimum of 25% of Type "A", "B" or "C" Active Uses on the ground floor If two[2] Shared Parking Structures face one another, at least one[1] of the two facing Façades shall include at minimum 75% of Active Uses on the Ground Floor
4.17.1 Ground Floor Blank Walls	(Not active use zone): Each Blank Wall shall not occupy over eight[8] linear ft. of Street Fronting Elevation. The total amount of Blank Wall shall be limited to 20% of the total Active Frontage.		Each Blank Wall shall not occupy over [12] linear ft. of Street Fronting Elevation. The total amount of Blank Wall shall be limited to 30% of the total Active Frontage.	N/A
4.17.2 Upper Floor Blank Walls	For all buildings, upper level Blank Walls shall not occupy over [30] linear ft. for the entire height of the façade above the base. The total amount of Blank Wall shall be limited to 50% of the total upper-level Building Façade. Shared property-line Building faces are exempt.			For Shared Parking Structures, Screening and/or openings shall not be considered Blank Walls. Green walls that are a significant architectural feature of the Façade will not be considered a Blank Wall Site utilities on Blocks 36B, 55 and/or 56 and Adaptive Reuse Buildings are exempt from the Blank Wall standard.

Figure 4.11f: GROUND FLOOR ACTIVATION ZONE CHART

4.11 Ground Floor Activation Cont'd

This table summarizes the ground floor design controls of the three different Ground Floor Activation types. Each of the controls listed here is defined in Section 4.11.

Ground Floor Frontage	Type "A"	Type "B"	Type "C"
4.11.3 Active Ground Floor Depth	All non-residential Buildings, not including service corridors, is [20] ft. For residential buildings the minimum is ten[10] ft.		
4.11.4 Ground Floor Heights	Minimum ground floor to floor height of [15] ft.		N/A
4.11.5 Waterfront Activation	Minimum [3,500] sq. ft. of publicly accessible Type "A" use shall be provided along the waterfront Façades of Blocks 26, 27 or 28. The amount of use may be in one or multiple spaces and/or Blocks	N/A	N/A
4.11.9 Ground Floor Active Use Transparency	Active Frontage shall be fenestrated with transparent windows and doorways and allow visibility to the inside of the Building to meet the minimum percentage for each Active Use type.		
4.11.10 Ground Floor Active Use Glass and Glazing	Active Frontage shall incorporate no less than 60% of transparent glazing in the vertical zone between four[4] ft. and eight[8] ft. in height from finished Ground Floor.		Active Frontage for Residential units shall incorporate no less than 30% of Transparent Glazing in the vertical zone between four[4] ft. and eight[8] ft. in height from the finished Ground Floor. Lobby and amenity spaces shall be 60% transparency glazing in the vertical zone between four[4] ft. and eight[8] ft. in height from the finished Ground Floor.

Figure 4.11g: GROUND FLOOR ACTIVATION TYPE CHART

4.12 Building Entries

- 4.12.1 Primary Building Entries
- 4.12.2 Green Room Building Entries
- 4.12.3 Ground Floor Residential Unit Entries
- 4.12.4 Building Entries

INTENT

To provide Ground Floor activation, pedestrian access to buildings and architectural articulation.

DEFINITIONS

"Primary Building Entries"

The main entries to a building.

STANDARDS

4.12.1 Primary Building Entries

All buildings shall have a Primary Building Entry from a public right-of-way, public open space, publicly accessible private open space, or Mid-Block Break.

4.12.2 Green Room Building Entries

Where a building is facing the Green Room, the Primary Building Entry shall front the Green Room

4.12.3 Ground Floor Residential Unit Entries

Ground Floor residential units shall be elevated above the street by a minimum average of between two[2] ft. and four[4] ft. Where street grades are in excess of 5% slope, the average height may exceed four[4] ft. in height.

GUIDELINES

4.12.4 Building Entries

Entrances shall be easily identifiable and well-lit for convenience, visual interest and increased safety. commercial/retail entrances shall be easily identifiable and distinguishable from residential entrances.

1. Clearly Defined Building Entry Example
2. Primary Building Entry Example
3. Entry to Residential Example



4.13 Parking and Service Entrances

- 4.13.1 Parking and Service Entrances Locations
- 4.13.2 Combined Parking and Service Entrances
- 4.13.3 Separate Parking and Service Entrances
- 4.13.4 Maximum Parking and Service Entrances
- 4.13.5 Parking and Service Entrances
- 4.13.6 Parking and Service Entrances (Blocks 38 & 45)

INTENT

Strategically locate Parking and Service Entrances in order to mitigate adverse impacts to pedestrians and bicyclists.

DEFINITIONS

"Parking Entrance"

Entries allowing vehicular access to parking areas, including Shared Parking Structures, podium parking, and/or below grade parking.

"Service Entrance"

Entries allowing vehicular access for trucks and/or deliveries, loadings, and/or access to trash rooms.

STANDARDS

4.13.1 Parking and Service Entrances Locations

Parking and Service Entrances are permitted in locations established by *Figure 4.13b*.

4.13.2 Combined Parking and Service Entrances

Each combined parking ingress and egress for off-street parking shall be a maximum width of [24] ft. This may be increased to a maximum of [27] ft. where:

- there is shared access to off-street parking and loading; or
- the extra width is necessary to accommodate the fleet of emergency services or utility providers.

4.13.3 Separate Parking and Service Entrances

Separate vehicular ingress/egress shall each be a maximum width of [11] ft. and be spaced at a minimum of [60] ft. apart.

4.13.4 Maximum Parking and Service Entrances

The sharing of parking and Service Entrances is encouraged. The number of entrances is limited to two[2] ingress and two[2] egress points per block plus one[1] Service Entrance. Shared vehicular entrances shall be a minimum of [40] ft. from block corners and [20] ft. from building entrances.

4.13.5 Parking and Service Entrances

Block 25 may host a transit center. Shall this block require loading access, the design of that access will be developed in close coordination with SFMTA to minimize any potential conflicts with the transit center operations.

GUIDELINES

4.13.6 Parking and Service Entrances (Blocks 38 & 45)

Blocks 38 and 45 shall minimize the impact of parking and Service Entrances on public open spaces. Options to minimize the impact may include providing separate ingress and egress access, locating parking and service access on an MBB, or similar strategies.

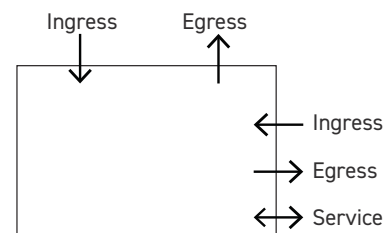

Figure 4.13a: PARKING INGRESS AND EGRESS PER BLOCK

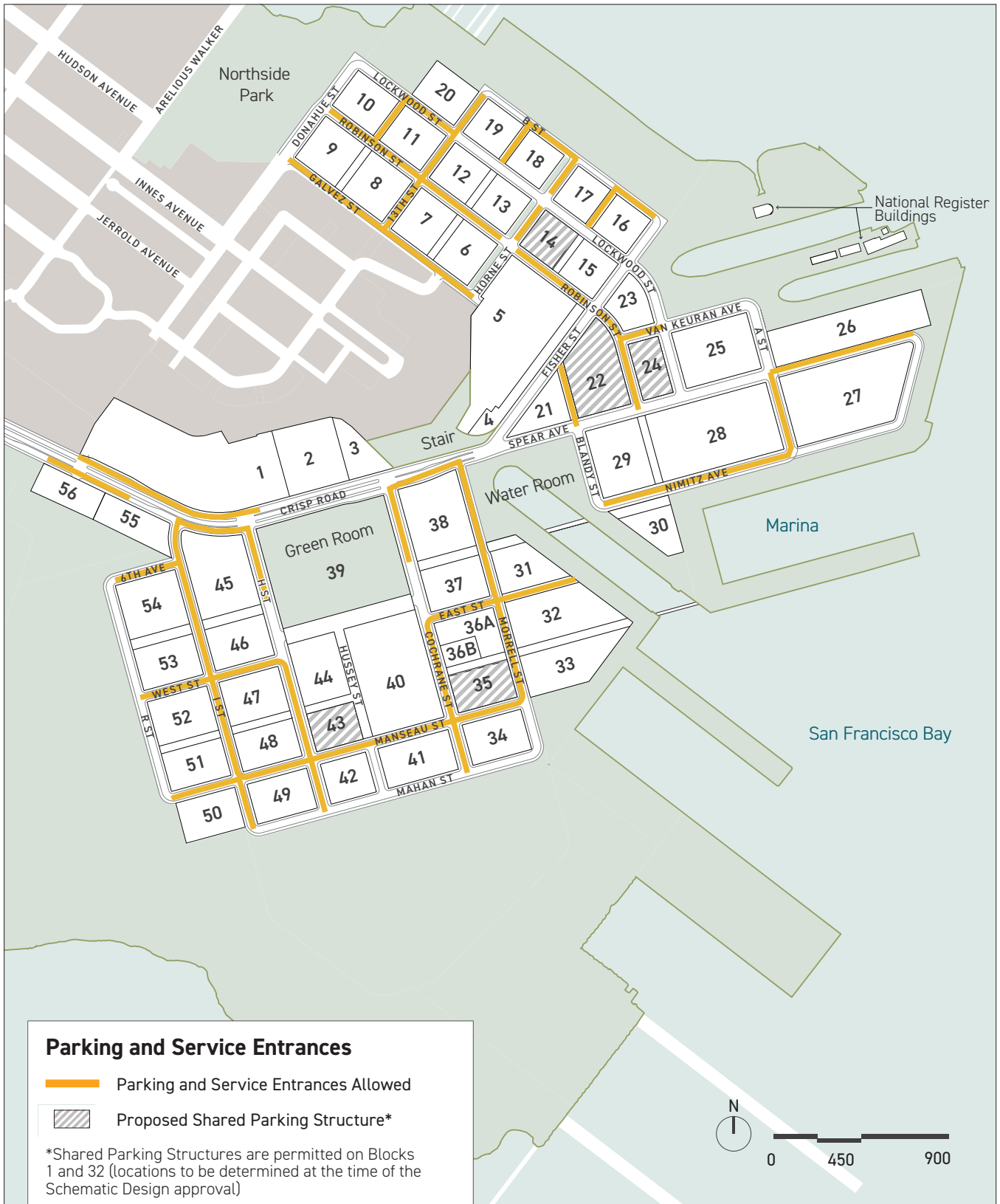

Figure 4.13b: PARKING AND SERVICE ENTRANCES

4.14 Screening

4.14.1 Screening

4.14.2 Screening of Utilities Visible at Grade

INTENT

To mitigate any adverse impacts of utilities, equipment, and vehicles on the Public Realm.

DEFINITIONS

"Screening"

A physical visual barrier that obstructs or obscures the view of an object or objects. Screening may include shading devices, trellises, canopies, fences, landscaping, and architectural treatments.

STANDARD

4.14.1 Screening

Screening is required to limit visibility of the following facilities and conditions:

- At-grade utilities visible from the Public Realm
- Utilities in the Setback areas
- Ground Floor utilities, mechanical rooms, and alcoves with exterior walls
- Eco-District or Eco-Grid utilities and utility facilities visible above ground
- Rooftop mounted equipment
- Vehicles in parking stalls, rooftops and ramps at shared parking garage structures and podium parking garages

Solar collectors and wind turbines are exempt.

4.14.2 Screening of Utilities Visible at Grade

Enclosure or Screening shall be designed as a logical extension of and/or compatible with the adjacent Building and an integral part of the overall Building design. Screening material and detailing shall be comparable in quality to that of the rest of the Building. Landscaping alone shall not qualify as Screening of at-grade utilities.



1

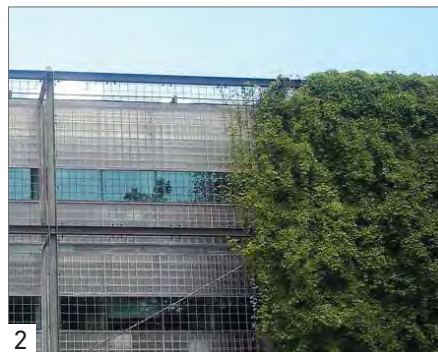

2



3

1. Metal Screening Example
2. Landscaping and Metal Screening Example
3. Metal Screening Example

4.14 Screening Cont'd

- 4.14.3 Screening Materials
- 4.14.4 Screening for Rooftop Equipment
- 4.14.5 Screening for Upper Floor Parking
- 4.14.6 Screening for Ground Floor Parking
- 4.14.7 Rooftop Screening for Parking

4.14.3 Screening Materials

Screening materials shall be durable and high quality. Screening shall be consistent with the architectural character of the building.

Examples of Screening Materials:

- **Landscaping:** Planting must include systems for maintenance, such as irrigation.
- **Concrete:** Cast-in-place or pre-cast concrete
- **Metal:** Panels, sheet materials, or shingles
- **Wood:** Paneling, and other natural materials
- **Glass:** Clear, colored, or translucent with reflectivity up to 50%.

4.14.4 Screening for Rooftop Equipment

Rooftop mechanical equipment and appurtenances to be used in the operation or maintenance of a building shall be arranged so as not to be visible from any point at or below the roof level of the subject building. Rooftop mechanical equipment shall be obscured by walls, parapet, or Screening.

Enclosure or Screening shall be designed as a logical extension of the building form and integral part of the overall building design. Cladding and detailing shall be comparable in quality to that of the rest of the building.

If the required Screening is an extension of the building wall below, the architectural treatment or characteristics shall be continued on the "screen" and the top of the equipment shall be below the maximum Building Height. Height Exceptions are noted in 4.4.3.

4.14.5 Screening for Upper Floor Parking

All parapet edges and/or façades shall be designed to screen vehicles from public view at all levels.

All parapet edges of parking trays, including the roofs, shall be high enough to screen adjacent properties from light trespass from vehicle headlights and direct view of building lighting.

Parking above the ground level shall be screened in a manner that accentuates ground floor uses, minimizes mechanical features and is in keeping with the overall massing and architectural vocabulary of the building.

4.14.6 Screening for Ground Floor Parking

Parking at the ground level shall be located at a minimum [25] ft. from any Setback line facing a public Right-of-way, MBB, or Open Space. Ground Floor parking in Shared Parking Structures and vertical mechanical parking structures may be located up to the Setback line. Ground Floor screening may include non-habitable spaces such as art installations, murals, green walls, landscaping, or similar uses.

4.14.7 Rooftop Screening for Parking

All exposed-to-the-sky parking stalls shall have shading or screening of one of the following types: trellises, solar collectors, PV trellises, trees, glass canopies, fabric shade structures or similar devices, such that parked vehicles cannot be viewed from any point below the roof level and not easily-viewed from adjacent buildings or public vista points.

4.15 Shared Parking Structures

- 4.15.1 Shared Parking Structure Locations
- 4.15.2 Number of Shared Parking Structures
- 4.15.3 Shared Parking Structure Design
- 4.15.4 Convertible Shared Parking Structures

INTENT

To provide architecturally integrated parking facilities that meet the needs and demands of the surrounding neighborhood.

DEFINITIONS

"Shared Parking Structure"

A separate structure providing Accessory Parking to off-site lawful non-Accessory uses and not attached to or included within a building containing a lawful non-Accessory use.

"Convertible"

A Shared Parking Structure designed to be converted into another use and/or designed to be mechanized and deconstructable.

STANDARDS

4.15.1 Shared Parking Structure Locations

Shared Parking Structures shall only be located on Blocks 1, 14, 22, 24, 32, 35, or 43. Shared Parking Structures on any other block not facing the waterfront, the Green Room or the Water Room shall require OCII Commission approval as a Secondary Use, pursuant to Secondary Use approval standards in the Plan. If a use other than a Shared Parking Structure is constructed in a Ground Floor Zone 4, the Ground Floor zone shall be revised to match the zone across the street, except along Robinson Street, which shall be Zone 2, Blocks 22, 24.

4.15.2 Number of Shared Parking Structures

A maximum number of seven^[7] Shared Parking Structures shall be permitted in HPS2. An increase in number of Shared Parking Structures beyond seven^[7] in HPS2 shall require OCII Commission approval

as a Secondary Use, pursuant to Secondary Use approval standards in the Plan, as well as to better serve the transportation and circulation needs of HPS2 while enhancing the pedestrian-level activation and urban design of HPS2.

4.15.3 Shared Parking Structure Design

Shared Parking Structures shall comply with all applicable Standards and Guidelines, including, but not limited to, Architectural Controls by Building Scale, Section 4.5.

4.15.4 Convertible Shared Parking Structures

Shared Parking Structure shall be Convertible. All floors shall be flat except required ramps for vehicular circulation.

Exception: A Shared Parking Structure that does not comply with the convertibility standard shall contain a 25% increase in Ground

4.15 Shared Parking Structures Cont'd

- 4.15.5 Floor Heights for Convertible Shared Parking Structures
- 4.15.6 Shared Parking Structure Lighting
- 4.15.7 Shared Parking Structure Ground Floor Uses

GUIDELINES

Floor Active Frontage over the minimum amount required in the Ground Floor Zones on *Figure 4.11d*. Shared Parking on Block 32 shall contain a minimum of 75% Active Frontage.

4.15.5 Floor Heights for Convertible Shared Parking Structures

Ground Floor height for Convertible Shared Parking Structures shall be a minimum [15] ft. All upper floors shall have nine[9] ft. clear floor to ceiling height. If a mechanical parking system does not contain structural floors, it is exempt from this Standard.

4.15.6 Shared Parking Structure Lighting

Security lighting shall be directed away from surrounding land uses using state-of-the-art fixtures to minimize light trespass and glare.

4.15.7 Shared Parking Structure Ground Floor Uses

Shared Parking Structures shall include Ground Floor facilities that support commuter cyclists including at least one[1] of the following: bike share facilities, changing rooms and showers, bike repair shops, bike racks, and/or secure bike storage.

1. Lighting at Parking Garage Example
2. Screening Example
3. Lighting at Parking Garage Example



4.16 Rooftops

4.16.1 Rooftop Façades

INTENT

To create distinctive or interesting roofs where visible from the hilltop or adjacent buildings.

DEFINITIONS

"High Albedo"

Materials that reflect sunlight and limit the amount of heat gained through those materials. High Albedo Roofing materials are chosen to reduce unwanted heating of roof surfaces.

"Vegetated Roof Covers"

A roof of a building that is partially or completely covered with vegetation and a growing medium, planted over a waterproofing membrane.

GUIDELINES

4.16.1 Rooftop Façades

Rooftops visible from the hilltop, adjacent buildings, and/or from spaces within the same building shall be designed as a "fifth façade".

The "fifth façade" can be met in the following ways: Where building roofs are free of solar panels, mechanical equipment, or other sustainability infrastructure, they shall be designed to include systems such as roofing materials with high albedo surfaces to reduce heat island effect or vegetated roof covers in order to reduce heat island effect and slow rainwater runoff.

1. Roof with Vegetated Cover Example
2. Roof with Solar Panel Example
3. Roof with Mechanical Equipment Example



This page is intentionally left blank.

4.17 Blank Walls

- 4.17.1 Ground Floor Blank Walls
- 4.17.2 Upper Floor Blank Walls

INTENT

To limit the location and expanse of Blank Walls and to provide greater building articulation and visual interest, especially at the Ground Floor level.

DEFINITIONS

"Blank Wall"

A building façade area greater than four[4] linear ft. in length parallel to the property line where there is not an entrance, window, or any building articulation, including solid doors and mechanical area wall(s).

STANDARDS

4.17.1 Ground Floor Blank Walls

Active Ground Floor Frontage Zone 1 & 2 (Not active use zone):

Each Blank Wall shall not occupy over eight[8] linear ft. of Street Fronting Elevation. The total amount of Blank Wall shall be limited to 20% of the total Active Frontage.

Active Ground Floor Frontage Zone 3:

Each Blank Wall shall not occupy over [12] linear ft. of Street Fronting Elevation. The total amount of Blank Wall shall be limited to 30% of the total Active Frontage. See *Figure 4.17a*.

Green walls that are a significant architectural feature of the Façade may not be considered a Blank Wall.

Site utilities on Blocks 36B, 55 and/or 56 and Adaptive Reuse Buildings are exempt from the Blank Wall standard.

4.17.2 Upper Floor Blank Walls

For all buildings, upper level Blank Walls shall not occupy over [30] linear ft. for the entire height of the façade above the base. The total amount of Blank Wall shall be limited to 50% of the total upper-level building Façade. Shared property-line Building Faces are exempt.

For Shared Parking Structures, screening and/or openings shall not be considered Blank Walls. Green walls that are a significant architectural feature integrated into the Façade will not be considered a Blank Wall.

Site utilities on Blocks 36B, 55 and/or 56 and Adaptive Reuse Buildings are exempt from the Blank Walls standards. See *Figure 4.17b*.

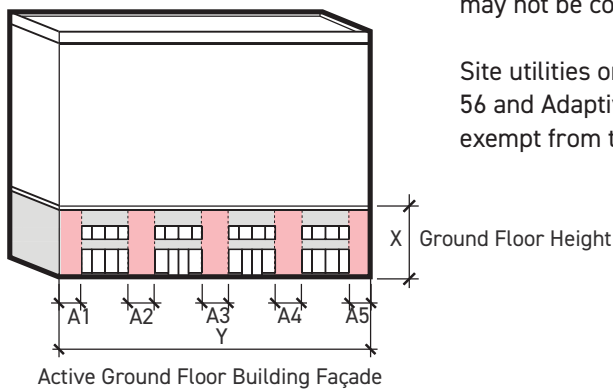

Zone 1 & 2 (A ≤ 8')

$$\frac{(A1+A2+A3+A4+A5)X}{XY} = \leq 20\%$$

Zone 3 (A ≤ 12')

$$\frac{(A1+A2+A3+A4+A5)X}{XY} = \leq 30\%$$

Figure 4.17a: GROUND FLOOR BLANK WALLS CALCULATION

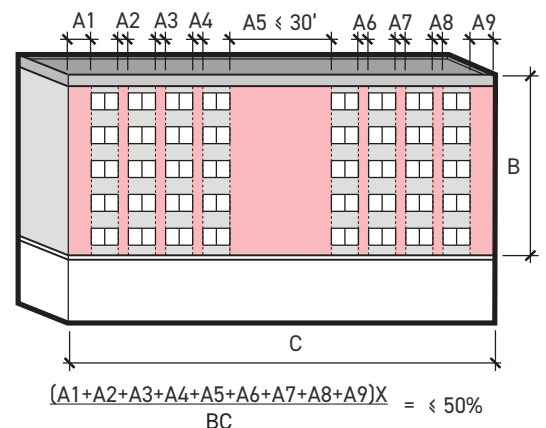

Figure 4.17b: UPPER FLOOR BLANK WALLS CALCULATION

4.18 Daylight

- 4.18.1 Residential Daylight
- 4.18.2 Commercial Daylight

INTENT

To ensure regularly occupied building areas have access to Daylight.

DEFINITION

"Daylight"

The controlled admission of natural light, direct sunlight, and diffused-skylight into a building to reduce electric lighting and save energy.

"Regularly Occupied Floor Area"

An area where one[1] or more individuals normally spend time (more than one[1] hour per person per day on average) seated or standing as they work, study, or perform other focused activities inside a building.

STANDARDS

4.18.1 Residential Daylight

All residential units shall have at least one[1] bedroom or living area with a window facing outside with an unobstructed view of a minimum [25] ft. clear dimension. See *Figure 4.18a*.

4.18.2 Commercial Daylight

Option 1:

All Regularly Occupied Floor Areas of commercial buildings shall have direct access and/or a view to the exterior courtyard of the building or a daylight Atrium space. See *Figure 4.18b*.

-OR-

Option 2:

At a minimum, 55% of the Regularly Occupied Floor Area shall be within a Floor Plate depth dimension of no greater than two and a half [2.5] times the glazing height. See *Figure 4.18c*.

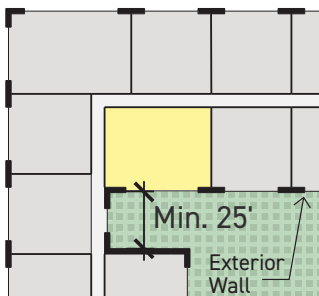

Figure 4.18a: RESIDENTIAL DAYLIGHT

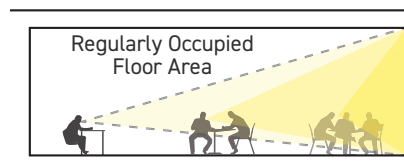

Figure 4.18b: COMMERCIAL DAYLIGHT OPTION 1

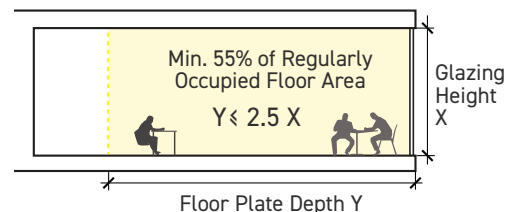

Figure 4.18c: COMMERCIAL DAYLIGHT OPTION 2

4.19 Façade Material

- 4.19.1 Bird-Safe Design
- 4.19.2 Material Quality
- 4.19.3 Material Selection
- 4.19.4 Ground Floor Materials
- 4.19.5 Marine Environment Materials
- 4.19.6 Prohibited Materials

INTENT

To ensure the durability and quality of materials particularly at the Ground Floor that will enhance the pedestrian visual experience.

Material and craft are essential to maintaining a reference to the past use of the site as a Shipyard.

Care shall be taken to reference the streetscape improvements such that the materiality of each district is harmonious as a whole, reinforcing the intention to achieve a subtle variation for each various district.

STANDARDS

4.19.1 Bird-Safe Design

All buildings shall fully comply with bird-safe measures established in the Mitigation Monitoring and Reporting Program for HPS2.

GUIDELINES

4.19.2 Material Quality

Materials shall be high quality, durable, and consistent with industry standards of contemporary architecture.

4.19.3 Material Selection

Material selection and application shall reflect the Material Palette. See material palette in *Figure 4.19a* for reference. The material palette does not preclude the use of other materials or finishes not listed if they are applied in concert with a strategy that fits the HPS2 Vision.

Building materials and colors shall be carefully selected to achieve harmony with neighboring buildings, be environmentally sensitive, and contribute to a varied urban street fabric.

4.19.4 Ground Floor Materials

Active Frontages shall be designed with high-quality materials that offer color, variety, wear resistance, and visual interest to the pedestrian.

- Consider fine grained material modules and textures at Ground Floor façades to enhance the pedestrian realm and provide contrast to the upper levels.
- Ground Floor Façades shall be finished with more than one[1] material and be unique to the individual program or building.

4.19.5 Marine Environment Materials

Due to the marine environment, materials selected shall demonstrate performance related to moisture protection, maintenance requirements, durability, and ultra violet resistance.

4.19.6 Prohibited Materials

Vinyl and fabric awnings are prohibited. Dryvit as a material is prohibited.

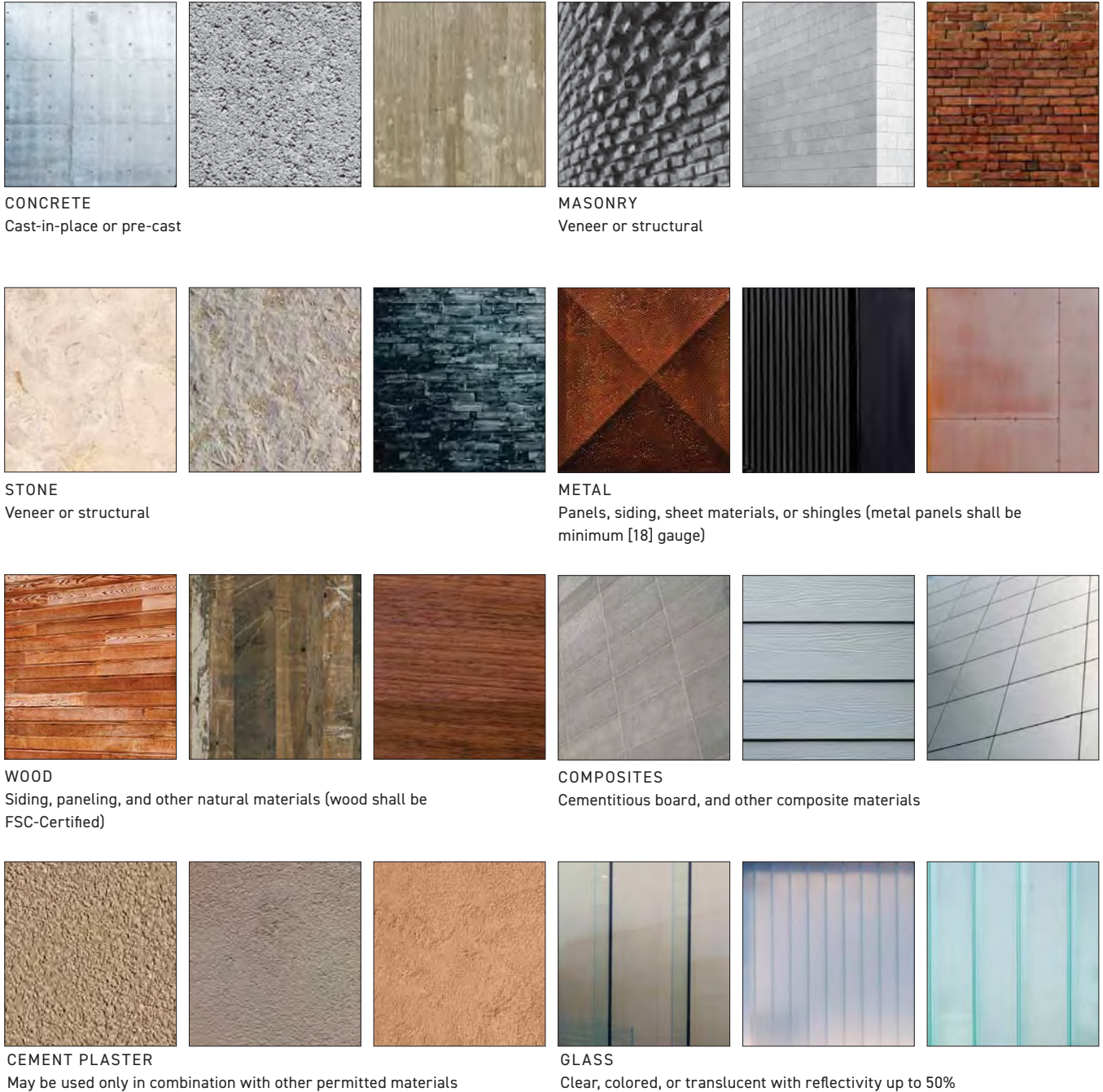

Figure 4.19a: MATERIAL PALETTE

4.19 Façade Material Cont'd

Water Room Palette

APPLICATION

ELEMENTAL MATERIALS:

The use of the following material and color palette is encouraged for the buildings fronting the Water Room and Dry Dock 4. See *Figure 4.19b*.

Materials at this location shall reflect the elemental qualities inherent in the idea of a Water Room.

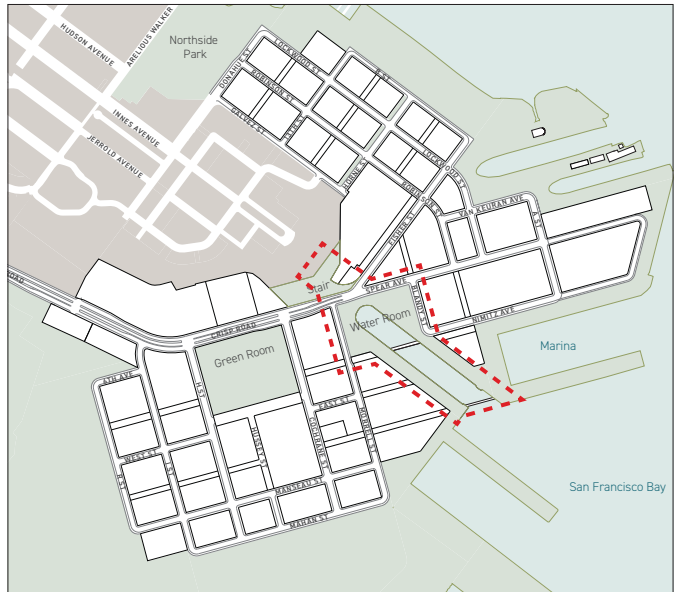
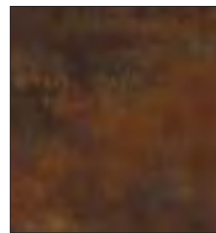

Figure 4.19b: LOCATION OF WATER ROOM



INDUSTRIAL/NAVAL CONCRETE



TINTED CONCRETES/COLORED AGGREGATES/ASPHALT



LIGHT STONE/
PRECAST CONCRETE



DARK STONE/
PRECAST CONCRETE

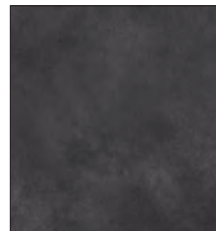

DARK METALS
(STANDARD USE)



WARM METALS
(STANDARD USE)



GLASS

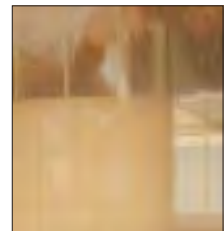

BACK-PAINTED GLASS/
TRANSLUCENT SCREENS



TERRACOTTA
BAGUETTES

Material and Color Palette is inspirational and can be used in conjunction with other materials.

Figure 4.19c: MATERIAL PALETTE

4.19 Façade Material Cont'd

Development Perimeter Palette

APPLICATION

POROUS & EARTHEN MATERIALS:
The use of the following material and color palette is encouraged for the waterfront and open space edges of the Shipyard North and Warehouse Districts. See *Figure 4.19d*.

Materials in this location shall relate the built environment along the edges of the development to the open spaces, the waterfront, and the sense of the natural topography of the shoreline.

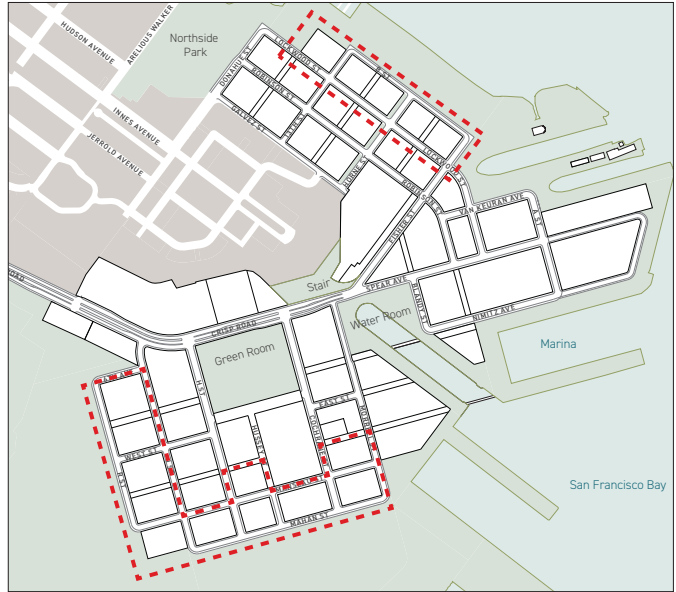
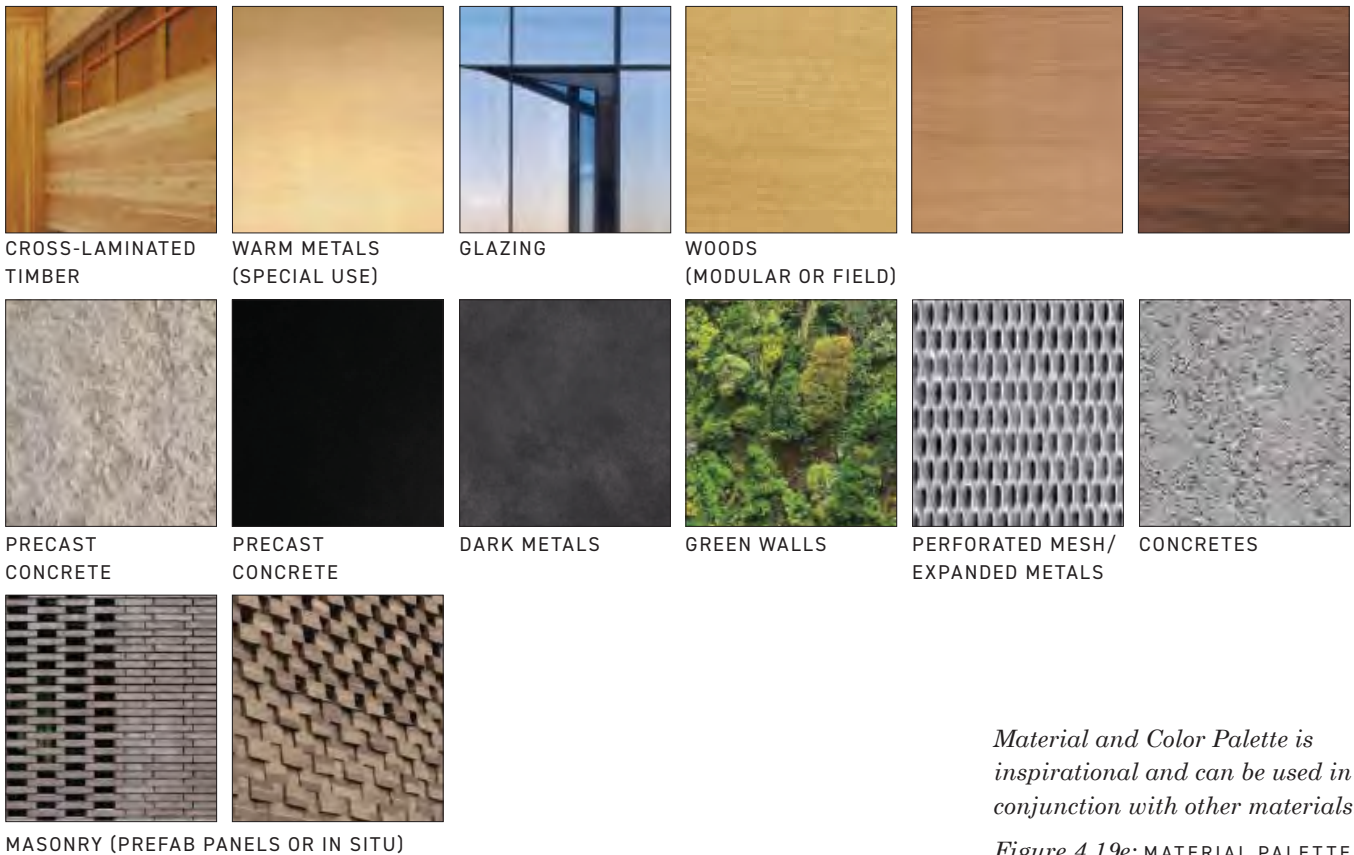

Figure 4.19d: LOCATION OF DEVELOPMENT PERIMETER



Material and Color Palette is inspirational and can be used in conjunction with other materials.

Figure 4.19e: MATERIAL PALETTE

4.19 Façade Material Cont'd

Green Room Palette

APPLICATION

“INVERSE” MATERIALS:

The use of the following material and color palette is encouraged for the buildings fronting the Green Room. See *Figure 4.19f*.

Materials at this location shall contribute to the urban edge and Street Wall of the Green Room, while allowing for ample Daylight into the buildings. A sense of lightness shall be perceptible from the Green Room.

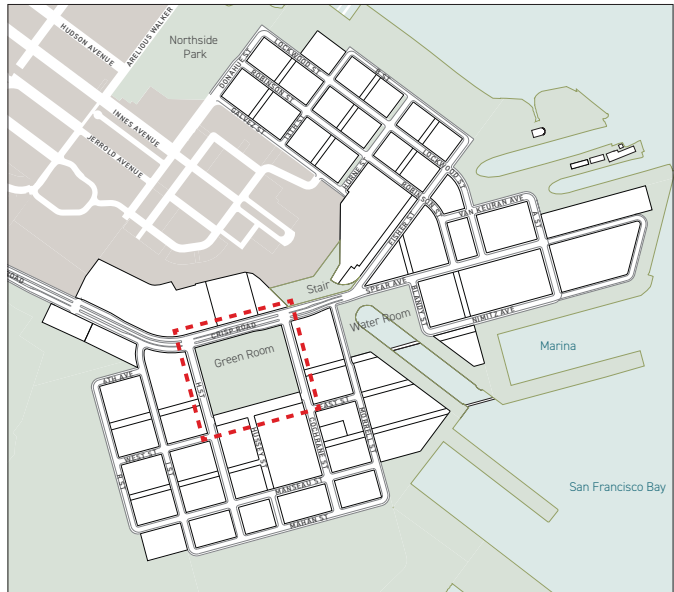
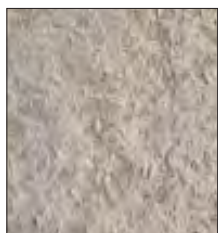

Figure 4.19f: LOCATION OF GREEN ROOM



LIGHT STONE/
PRECAST CONCRETE



DARK STONE/
PRECAST CONCRETE

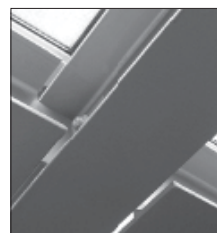

EXPOSED STEEL



CROSS-LAMINATED
TIMBER/GLULAM

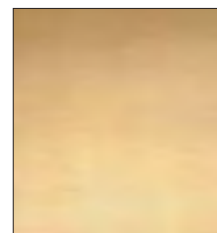

WARM METALS
(STANDARD USE)

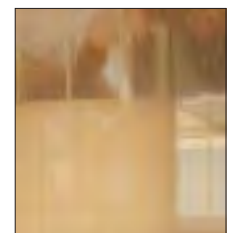

BACK-PAINTED GLASS/
TRANSLUCENT SCREENS

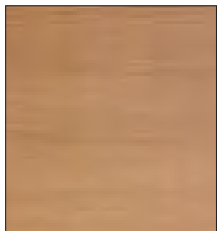

WOODS (MODULAR OR FIELD)

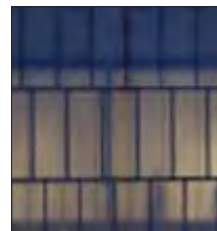

TINTED/OPAQUE
GLAZING/SPANDRELS

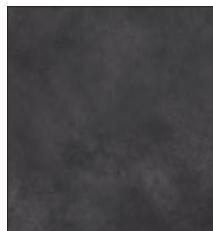

DARK METALS



GROUND LEVEL GLASS
FOR RETAIL (TRANSPARENT)

Material and Color Palette is inspirational and can be used in conjunction with other materials.

Figure 4.19g: MATERIAL PALETTE

4.19 Façade Material Cont'd

Research District and Transit Hub Palette

APPLICATION

INDUSTRIAL MATERIALS:

The use of the following material and color palette is encouraged for the waterfront and open space edges of the Shipyard North and Warehouse Districts. See *Figure 4.19h*.

Materials at this location shall reference the former industrial uses of buildings on these blocks.

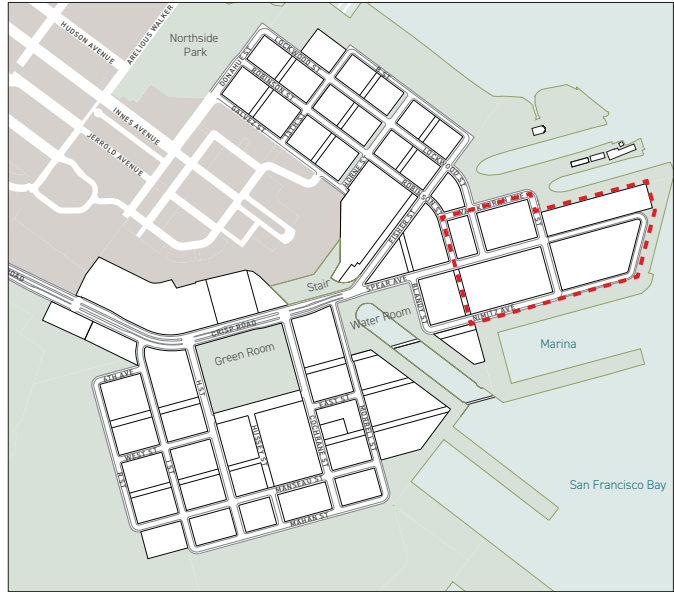
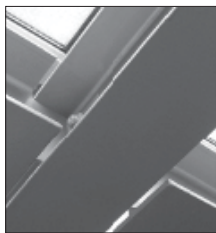

Figure 4.19h: LOCATION OF RESEARCH DISTRICT AND TRANSIT HUB



EXPOSED STEEL



LIGHT METALS

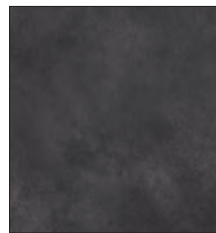

DARK METALS



PRECAST CONCRETE/
METALS

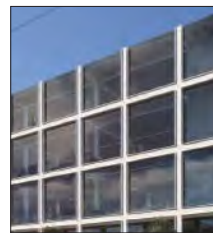

STRUCTURAL STEEL/
CURTAIN WALLS



GLASS Façade/
CONCRETED STRUCTURE



METAL FINNS



CAST IN PLACE
CONCRETE

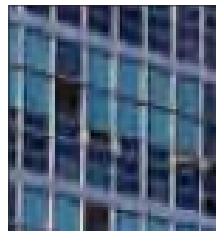

GLASS CURTAIN
WALL



TERRACOTTA
BAGUETTES

Material and Color Palette is inspirational and can be used in conjunction with other materials.

Figure 4.19i: MATERIAL PALETTE

4.19 Façade Material Cont'd

Pedestrian Allée Palette

APPLICATION

MATERIAL VARIETY:

The use of the following material and color palette is encouraged for the Pedestrian Allée. See *Figure 4.19j*.

Materials that front the Pedestrian Allée shall provide varied experience as one moves through the allée. Materials shall reinforce the scale of the buildings and be compatible with the adjacent districts.

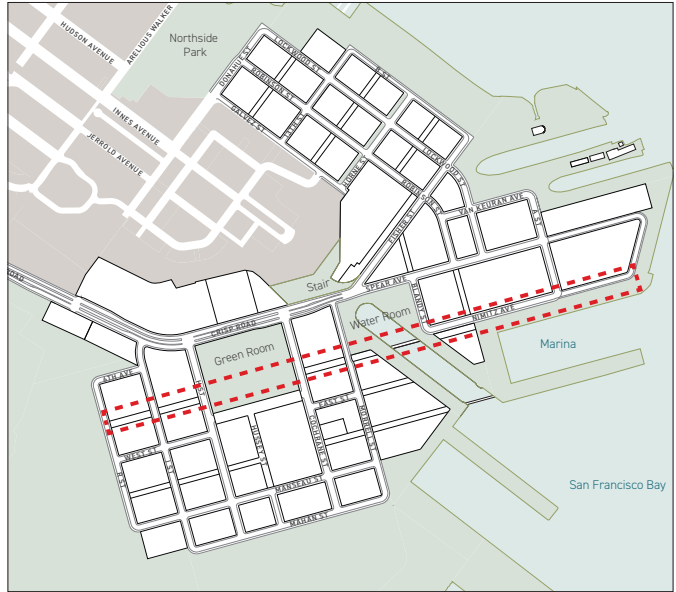

Figure 4.19j: LOCATION OF PEDESTRIAN ALLÉE



CROSS-LAMINATED
TIMBER



MASONRY (PREFAB
PANELS OR IN SITU)



WOODS
(MODULAR OR FIELD)

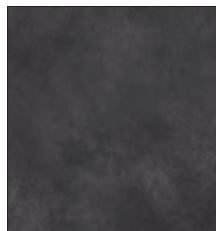

DARK METALS

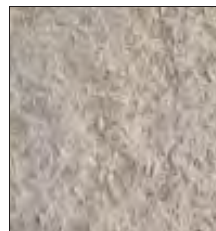

LIGHT STONE /
PRECAST CONCRETE

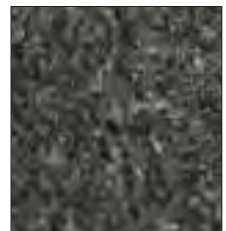

DARK STONE /
PRECAST CONCRETE



METAL FINES



TERRACOTTA BAGUETTES

Material and Color Palette is inspirational and can be used in conjunction with other materials.

Figure 4.19k: MATERIAL PALETTE

4.19 Façade Material Cont'd

Fisher Street Palette

APPLICATION

URBAN EDGE:

The use of the following material and color palette is encouraged for Fisher Street. See *Figure 4.19l*.

Materials at this location shall reinforce an urban edge along Fisher Street.

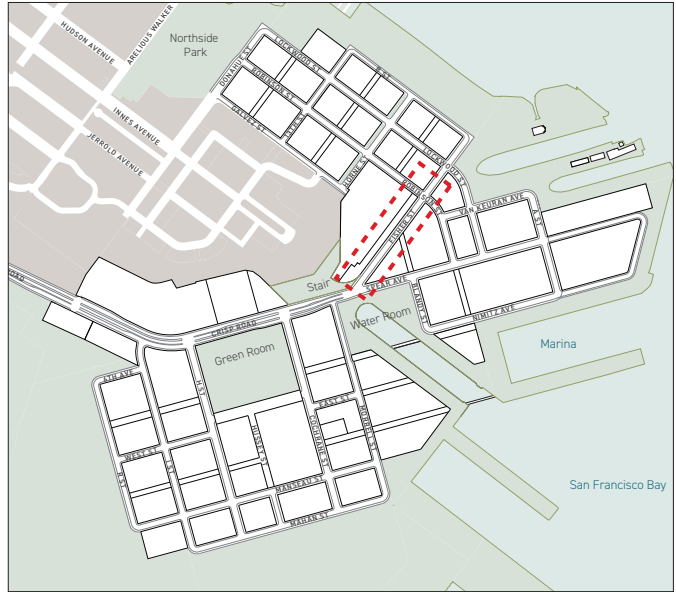
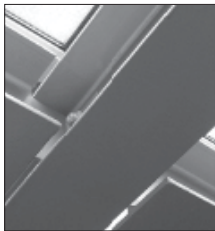

Figure 4.19l: LOCATION OF THE VILLAGE CENTER



EXPOSED STEEL



GLASS



TRANSLUCENT GLAZING

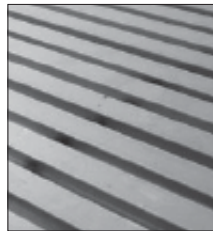

CORRUGATED STEEL



METAL FINES

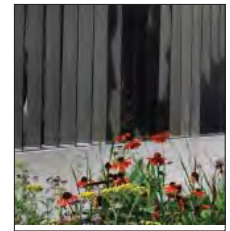

METAL FINES

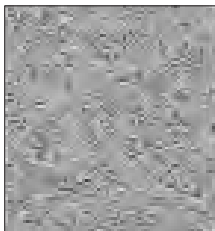

POLISHED STANDARD CONCRETE

Material and Color Palette is inspirational and can be used in conjunction with other materials.

Figure 4.19m: MATERIAL PALETTE

This page is intentionally left blank.

4.20 Class I - Bicycle Parking

- 4.20.1 Bicycle Parking Capacity
- 4.20.2 Bicycle Parking Location

INTENT

To provide safe, secure and convenient bicycle parking for residents, workers and visitors.

DEFINITIONS

"Class I - Bicycle Parking"

Spaces in secure, weather-protected facilities intended for use as long-term, overnight, and workday bicycle storage by dwelling unit residents, non-residential occupants, and employees.

STANDARDS

4.20.1 Bicycle Parking Capacity

Class I Bicycle parking shall be provided at the following ratios for the occupied floor area:

Office/R+D	1sp/5,000 sf
Community/Arts	1sp/5,000 sf
Retail/Restaurants	1sp/7,500 sf
Maker Spaces	1sp/7,500 sf
Hotel	1sp/30 room
School	4sp/classroom
Childcare	1sp/20 children
Residential	1sp/unit up to 100 units 1sp/4 units above 100 units
Group/Senior Housing	1sp/10 units

4.20.2 Bicycle Parking Location

Class I Bicycle parking shall be provided for new building construction and adaptive re-use buildings. Bicycle Parking access shall be conveniently located, which may include locations on floors other than the ground floor, provided that pathways to reach Bicycle Parking are designed specifically to accommodate bicycles, (e.g. elevator sizes, hallway widths, etc shall be adequately sized for bicycles specifically).

Commercial bicycle parking may be consolidated in a separate building that is located either adjacent to or across the street from an access point to the subject building.

4.21 Vehicle Parking and Loading

4.21.1 Vehicle Parking and Loading

INTENT

To limit the number of vehicle parking spaces by land use and ensure adequate loading and service areas.

STANDARDS

4.21.1 Vehicle Parking and Loading

Parking and Loading minimum and maximum ratios shall be as follows in Figure 4.21a, Figure 4.21b, Figure 4.21c, and Figure 4.21d. Parking may be provided in individual buildings together with the Principal or Secondary Use(s) served by such Parking or provided in Shared Parking Structures which serve one or more lawfully-permitted uses within HPS2.

MAXIMUM PARKING REQUIREMENTS	
Land Use	Rate
Residential	1 per unit
Regional Retail	3.0 per 1,000 sq. ft.
Neighborhood Retail/Maker Space	3 per 1,000 sq. ft.
Office	1 per 1,000 sq. ft.
Research and Development	1.3 per 1,000 sq. ft.
Hotel	0.25 per room
Film Arts Center	1 per 8 seats up to 1,000 seats, 1 per 10 above 1,000 seats
Artist's Space	1 per 2,000 sq. ft.
Community Uses	1 per 2,000 sq. ft.
Institution/School	0.07 per 1,000 sq. ft.
Marina Slips	0.6 per slip

Figure 4.21a: MAXIMUM PARKING REQUIREMENTS

CAR SHARE PARKING SPACE REQUIREMENTS	
Number of Residential Units	Number of Required Car Share Parking Spaces
0-49	0
50-200	1
201 or more	2, plus 1 for every 200 dwelling units over 200
Number of Parking Spaces Provided for Non-Residential Uses or in a Non-Accessory Parking Facility	Number of Required Car Share Parking Spaces
0-24	0
25-49	1
50 or more	1, plus 1 for every 50 parking spaces over 50

Figure 4.21b: CAR SHARE PARKING SPACE REQUIREMENTS

4.21 Vehicle Parking and Loading Cont'd

4.21.1 Vehicle Parking and Loading

OFF-STREET FREIGHT LOADING SPACE REQUIREMENTS OUTSIDE OF MEDIUM- AND HIGH-DENSITY RESIDENTIAL BLOCKS		
Land Use	Size of Use	Number of Spaces Required (per block)
Retail, Wholesale, Manufacturing, Live/Work	0-10,000 sq. ft.	0
	10,000 - 60,000 sq. ft.	1
	60,000 - 100,000 sq. ft.	2
	> 100,000 sq. ft.	3, plus 1 for each additional 80,000 sq. ft.
Offices, Hotels, Residential and All Other Uses	0-100,000 sq. ft.	0
	100,000 - 200,000 sq. ft.	1
	200,000 - 500,000 sq. ft.	2
	> 500,000 sq. ft.	3, plus 1 for each additional 400,000 sq. ft.

Figure 4.21c: OFF-STREET FREIGHT LOADING SPACE REQUIREMENTS OUTSIDE OF MEDIUM- AND HIGH-DENSITY RESIDENTIAL BLOCKS

OFF-STREET FREIGHT LOADING SPACE LIMITS MEDIUM- AND HIGH-DENSITY RESIDENTIAL BLOCKS		
Land Use	Size of Use	Number of Space Permitted (per block)
Non-Residential Uses	0-50,000 sq. ft.	1
	>50,000 sq. ft.	1 space per 50,000 sq. ft.
Residential - Low Density	0 - 100 units	1
Residential - High Density	> 100 units	1, plus 1 additional loading space for every 200 additional units
Total Number of Loading Spaces Allowed for Any Single Building (all uses)		4

Figure 4.21d: OFF-STREET FREIGHT LOADING SPACE LIMITS MEDIUM- AND HIGH-DENSITY RESIDENTIAL BLOCKS

4.22 Skyway Connections

4.22.1 Skyway Connections

INTENT

To provide upper level connections between buildings.

DEFINITION

"Skyways"

Upper level connections between buildings are primarily for pedestrians although they could also be used for small service vehicles. Skyways may be enclosed or open air.

STANDARDS

4.22.1 Skyway Connections

Skyways are permitted in the locations indicated in *Figure 4.22a* and only to the extent described below.

All Skyways shall provide a minimum of [30] ft. of vertical clearance below, to allow full pedestrian and automobile access at grade. Each Skyway shall be no wider than [30] ft. and no taller than one[1] story in height. Ground level landscaping may be adjusted as required to allow for solar access.

MBBs between Blocks 44 & 43, 35 & 36, and 28 & 29 shall have no more than two[2] Skyways each. The MBB between Blocks 32 & 33 shall have no more than three[3] Skyways.



Figure 4.22a: SKYWAY CONNECTIONS

4.23 Green Room Datum

4.23.1 Green Room Datum

INTENT

To provide a consistent architectural expression to unify the façades framing the Green Room.

DEFINITIONS

"Datum"

An articulation strategy on the building façade that, by its continuity and regularity, serves to gather, measure, and organize the pattern of forms and spaces.

STANDARDS

4.23.1 Green Room Datum

All buildings facing the Green Room are required to incorporate an architectural expression of the established Datum. This may be achieved by modulation in the building Façade, a change in material, or another architectural feature.

The Datum elevation shall be set by the first building constructed on the Green Room and be located between [15] ft. and [30] ft. above the sidewalk grade for that building. All future buildings around the Green Room are to match the approximate initial Datum elevation (minor deviations in Datum height, less than three[3] ft. may occur).

Datum Articulation Strategies

Choose at least one[1] strategy:

- DS1 Cornice at the Datum
- DS2 Change in material at the Datum
- DS3 Change in color at the Datum
- DS4 Change in building articulation at the Datum
- DS5 Change in building modulation at the Datum
- DS6 Canopies located at the Datum
- DS7 Increase Ground Floor Transparency facing the Green Room to 80% for commercial façades and 60% for residential façades for the entire area up to the Datum
- DS8 Applied Materials at the Datum

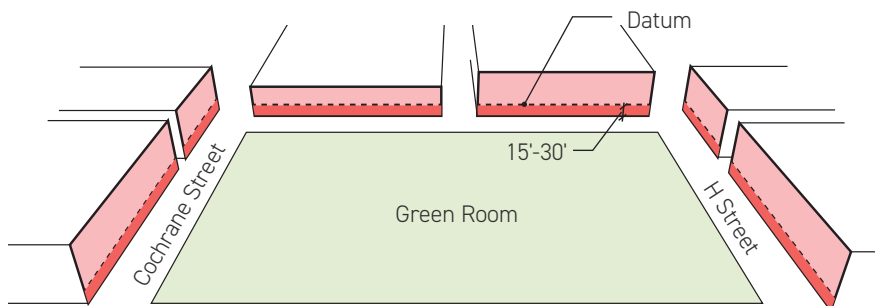

Figure 4.23a: GREEN ROOM DATUM

4.23 Green Room Datum Cont'd



1. Datum: Cornice Creates Datum Example
2. Datum: Change in Architectural Articulation / Modulation Example
3. Datum: Change in Material and Plane Example

4. Datum: Canopy Example
5. Datum: Change in Color and Plane Example
6. Datum: Change in Transparency Example

4.24 Adaptive Reuse

4.24.1 Adaptive Reuse

INTENT

There are a number of buildings that have not been officially recognized as cultural resources that reflect historic development patterns of the Hunters Point Shipyard and provide visual interest, cohesion, and a sense of the history of the site. As such, the following standards are intended to encourage the retention of these character-enhancing structures.

DEFINITIONS

“Adaptive Reuse”

Reuse or recreation of an existing structure in part or whole, in a manner that maintains the essence and character-defining building elements of the existing structure. Projects that propose adaptive reuse of any of the following buildings (140, 204, 205, 207, 211, 224, 231, 253) shall provide a written summary of compliance with the then-current Secretary of the Interior’s Standards and Guidelines for Rehabilitation.

“Character-Enhancing Structures”

Buildings or structures that may be adaptively reused to enhance the neighborhood character and sense of place, as shown in Figure 4.24a. Detailed information regarding the specific designations of National Register Buildings and others to be studied or considered for retention can be found in the companion documents. (Refer to Section 1.2)

STANDARDS

4.24.1 Adaptive Reuse

When adopted, the Adaptive Reuse of an existing building shall retain at least one[1] public expression of a character-defining building element from the list below for the portions of the building that remain:

Building Elements

1. **Roof Profile:** Retain or replicate at least 50% of the character-defining roof profile.
2. **Structural System:** Retain, retrofit or replicate at least 75% of the character-defining external or internal structural systems. The structural system need not perform in its original function to be considered a character-defining feature.
3. **Building Enclosure:** Retain, replicate or rebuild at least 75% of the building enclosure in a manner that is consistent with the existing character, but may be different in materiality and transparency so long as such qualities are publicly expressed.
4. **Character-Defining Features:** Demonstrate a comprehensive and cohesive scheme that incorporates multiple features of one[1] or more character-defining building elements. Such scheme shall publicly express such character and represent a creative re-imagining of the existing building features without necessarily meeting the quantitative requirements of the three[3] building elements noted above (Roof Profile, Structural System, Building Enclosure).

1. Adaptive Reuse Example
2. Adaptive Reuse Example





Figure 4.24a: EXISTING STRUCTURES

4.24 Adaptive Reuse Cont'd

4.24.2 Adaptive Reuse Exemptions

STANDARDS

4.24.2 Adaptive Reuse Exemptions

Where other standards in this document conflict with the Adaptive Reuse Standards or prevent the retention of a Contributory or Character-Enhancing Structure, the Adaptive Reuse project shall be exempt from such Standards. Specifically, development projects that comply with the Adaptive Reuse Standards shall be exempt from the following (other standard exemptions will be considered on a case-by-case basis):

- 4.2.1 Building Setback
- 4.3.1 Developable Area Coverage
- 4.4.5 Street Wall
- 4.5.2 Maximum Plan Length
- 4.6.1 Façade Composition
- 4.7.1 Bulk and Massing Approach
- 4.16.1 Rooftop Façades
- 4.17.1 Ground Floor Blank Walls
- 4.17.2 Upper Floor Blank Walls
- 4.23.1 Green Room Datum

Additions to Contributory or Character-Enhancing Structures are also exempt from these Standards. Designs are allowed to increase the height of the existing structure within the allowable Building Height. Vertical and horizontal additions should be clearly identifiable, but visually harmonious with the existing building's features and scale.

Development improvements extending horizontally outside of the original footprint shall comply with all relevant standards if the addition is not extending, highlighting, or reacting/responding to the character of the features of the existing structure.

4.25 Key Sites Blocks 28 and 40

4.25.1 Key Sites Blocks 28 and 40

INTENT

To assure that buildings on Blocks 28 and 40 are either retained pursuant to the Adaptive Reuse controls, or are redeveloped with exemplary architectural design.

STANDARDS

4.25.1 Key Sites Blocks 28 and 40

In addition to all applicable standards for new construction, apply one[1] additional **BE/PE** Building or Public Realm Enhancement Measure.

In addition, apply one[1] of the options below:

Option 1

Allow pedestrian access through the site at the Ground Floor using the following strategies:

- Provide Ground Floor public access through the block
- Public access shall be open during regular business hours
- The connection may be open to air or enclosed
- Upper floor connections above the pedestrian throughway area are permitted
- The scale of the connection shall be of a width and height that is inviting to the public

Option 2

Develop an architectural quality that meets or exceeds the expression and character of the Adaptive Reuse building using the following strategies:

- Building design shall be uniquely identifiable from afar
- Building design shall enhance the pedestrian experience through incorporation of tactile and fine grain materials
- Building design shall evoke or reference the character-defining elements of the building it replaces

4.26 Private Open Space

- 4.26.1 Private Open Space
- 4.26.2 Private Common Open Space on Waterfront Blocks
- 4.26.3 Private Setbacks
- 4.26.4 Fences

INTENT

To provide opportunities for individuals to seek a moment of respite or congregate with others in open space.

DEFINITION

"Residential Private Individual Open Space"

Intended for the use of individual residents within a unit and include terraces, patios, balconies, rooftop spaces and other similar areas.

"Residential Private Common Open Space"

Intended to be shared by all residents/users within a building or building cluster and includes rooftop spaces, internal courtyards, gardens, pools, play areas, and other similar areas.

STANDARDS

4.26.1 Private Open Space

Every residential building shall have a minimum net usable Private Open space equivalent to [60] sq. ft. per unit. Private Open Space shall be located on the same parcel as the residents it serves. Any combination of private or common open space may be used to count towards meeting this requirement.

Private Individual Open Space

Residential Private Individual Open Space shall be a minimum of [36] sq. ft. with a six[6] ft. linear dimension.

Private Common Open Space

Residential Private Common Open Space shall be a minimum [15] ft. linear dimension.

A Projection shall maintain nine[9] ft. of vertical clearance to the ground floor in order for the space beneath the Projection to be considered an open space. See *Figure 4.26a* to *Figure 4.26g*.

4.26.2 Private Common Open Space on Waterfront Blocks

Residential buildings adjacent to the waterfront shall have a courtyard opening to the waterfront.

4.26.3 Private Setbacks

The Setback zone of all residential buildings shall be used either to create high quality, usable open space for street facing units, or in the case of building entrances to create a transition zone between private-use and the public realm. Permitted uses within the Setback zone include street-facing stairs, stoops, porches, patios, landscaping, driveways and entry plazas. The Setback zone shall be landscaped with high quality materials from the building edge to the public sidewalk. Residential Ground Floor open space shall follow San Francisco "Guidelines for Ground Floor Residential Design".

4.26.4 Fences

In order to define Private Open Spaces of Ground Floor units, the following can be used: fences, railings, gates, grilles, planters and retaining walls to delineate private from public space. Such elements may be up to three[3] ft. high. If less than 25% opaque, such elements may be up to three and a half[3.5] ft. high.

4.26 Private Open Space Cont'd

- 4.26.5 Defensible Spaces
- 4.26.6 Orientation
- 4.26.7 Planting Palette
- 4.26.8 Irrigation

GUIDELINES

4.26.5 Defensible Spaces

Stoops and patios shall provide safety measures to ensure the space is defensible. Defensible design includes gates and railings, planters, and appropriate landscaping to provide a buffer from the street, while also allowing for visual connections between the street and the residence.

4.26.6 Orientation

Buildings shall maximize solar access and views of private common open spaces. Balconies on high-rise towers are encouraged to be located away from building corners that face the prevailing wind direction.

4.26.7 Planting Palette

Native and climate appropriate plants are encouraged.

4.26.8 Irrigation

Water demand shall be minimized by carefully controlling irrigation timing and application as well as plant selection.



1



2



3



4

1. Private Common Open Space - Rooftop Example
2. Private Individual Open Space - Balcony Example
3. Private Common Open Space - Internal Courtyard Gardens Example
4. Private Individual Open Space - Front Yard Example

4.26 Private Open Space Cont'd

Setback Zone 1 - Refer to Page 56 Setback requirements

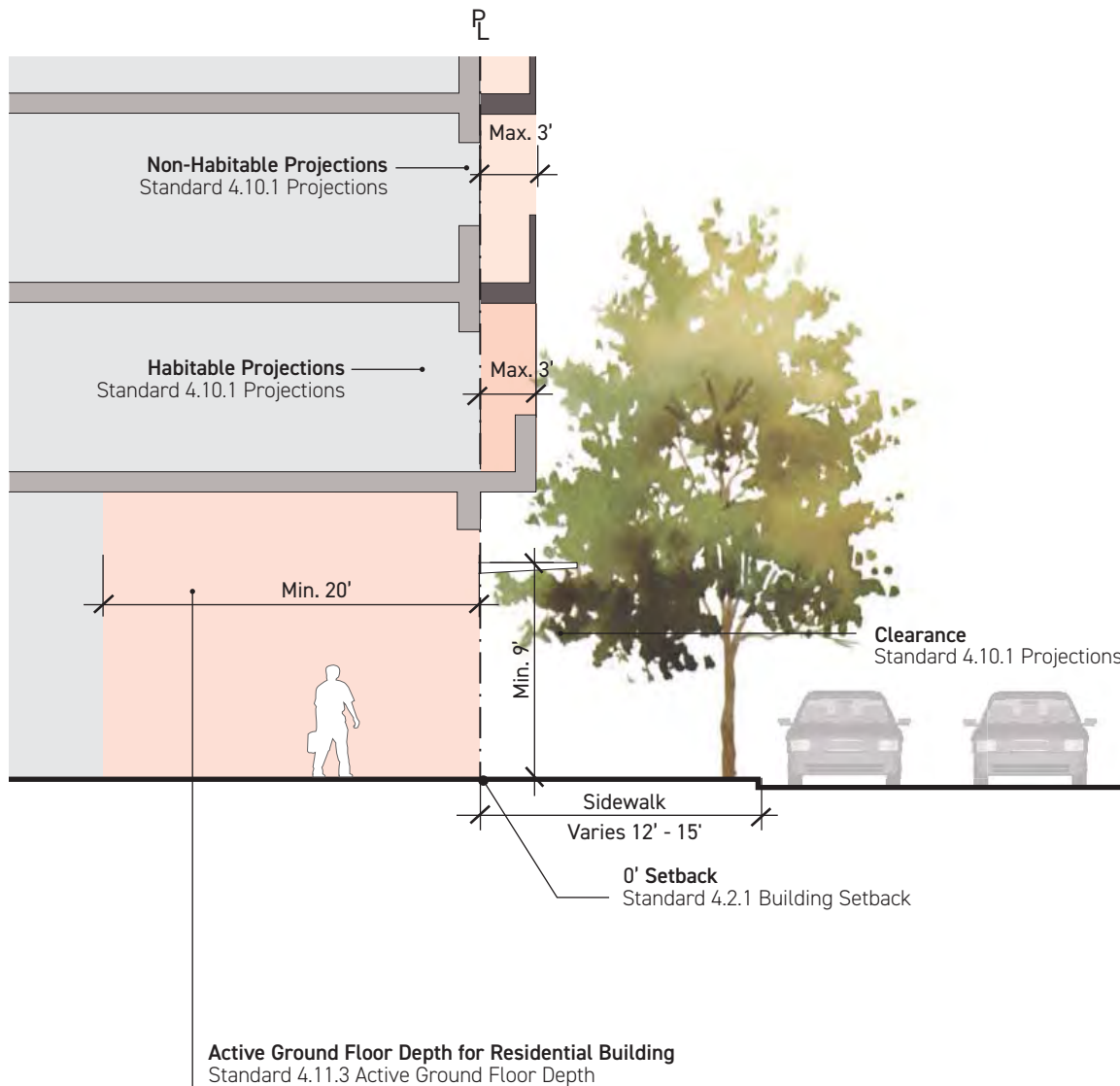

Figure 4.26a: SETBACK ZONE 1 (0' MIN./0' MAX.)



4.26 Private Open Space Cont'd

Setback Zone 2 Variation 1 - Refer to Page 56 Setback requirements

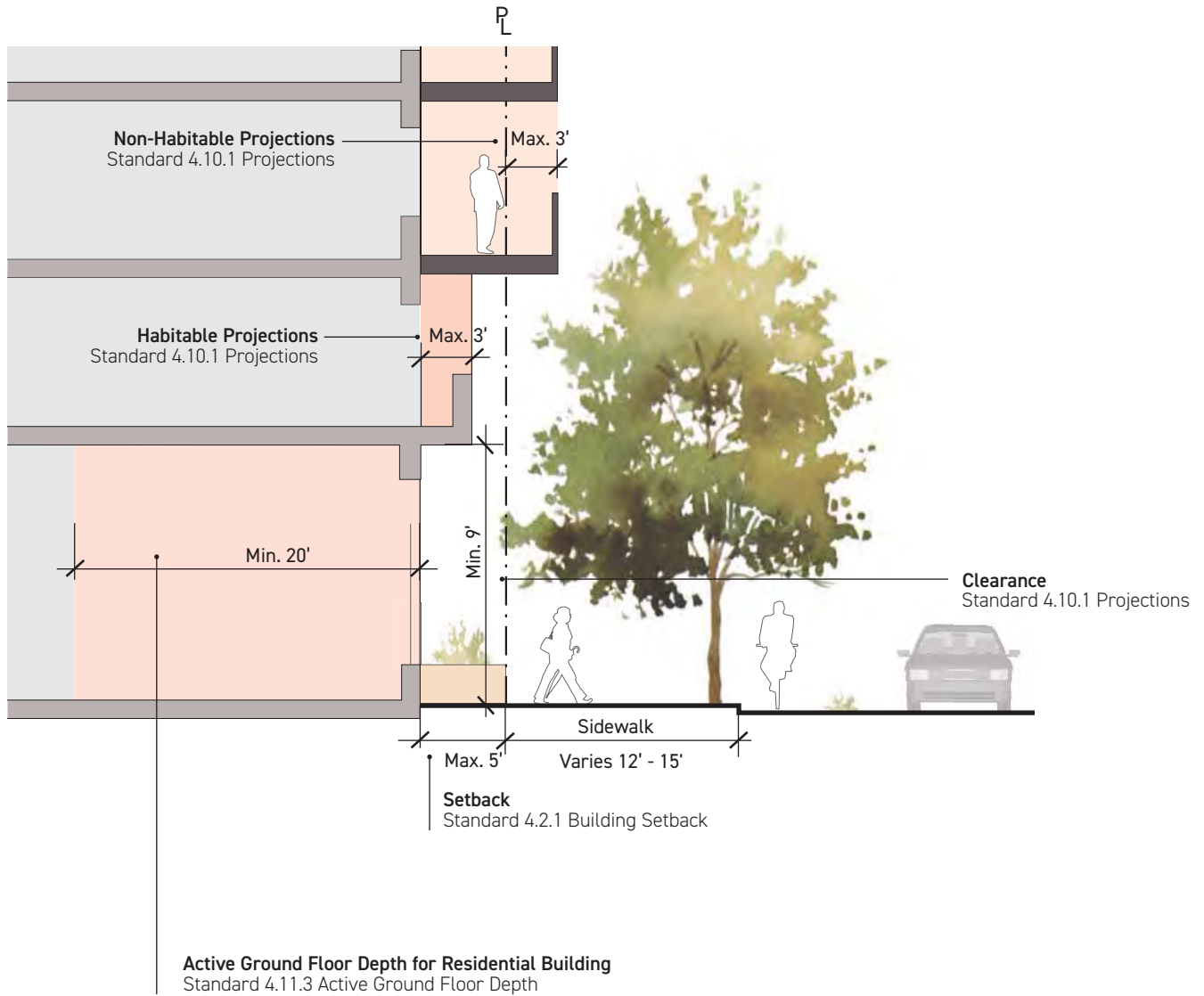

Figure 4.26b: SETBACK ZONE 2 VARIATION 1 (0' MIN./5' MAX.)



4.26 Private Open Space Cont'd

Setback Zone 2 Variation 2 - Refer to Page 56 for Setback requirements

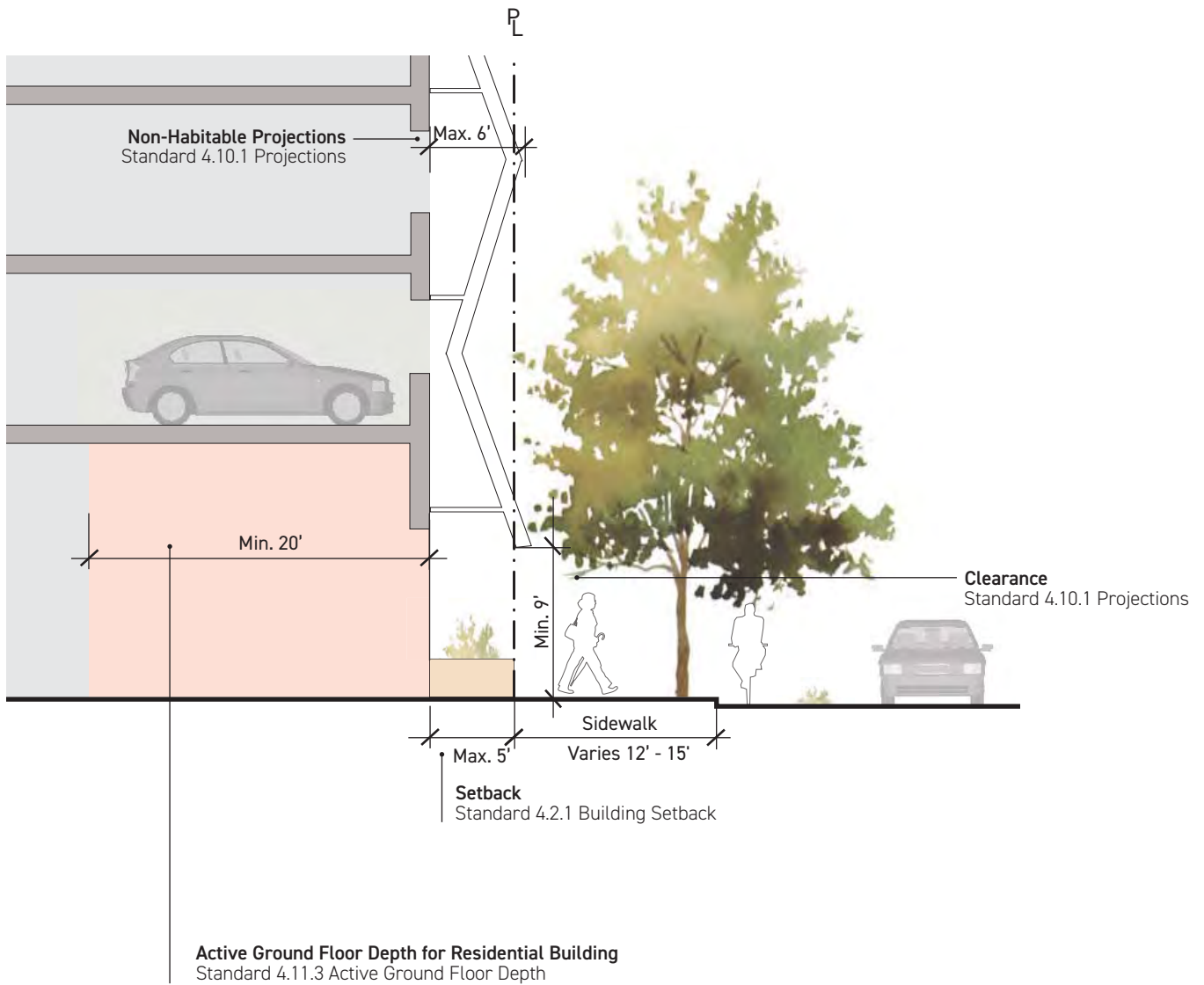

Figure 4.26c: SETBACK ZONE 2 VARIATION 2 (0' MIN./5' MAX.)



4.26 Private Open Space Cont'd

Setback Zone 3 - Refer to Page 56 for Setback requirements

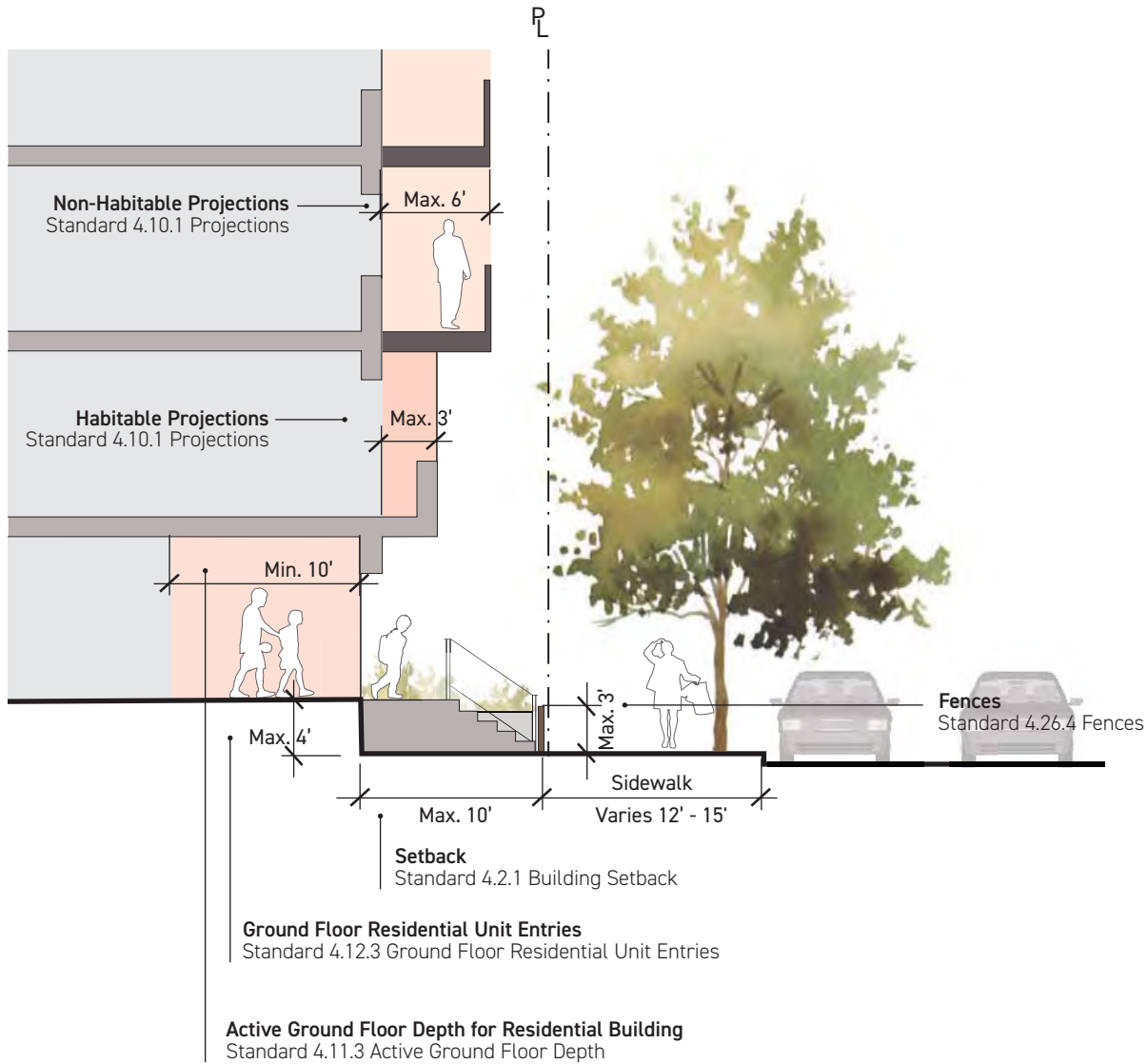

Figure 4.26d: SETBACK ZONE 3 (5' MIN./10' MAX.)



4.26 Private Open Space Cont'd

Setback Zone 4 - Refer to Page 56 for Setback requirements

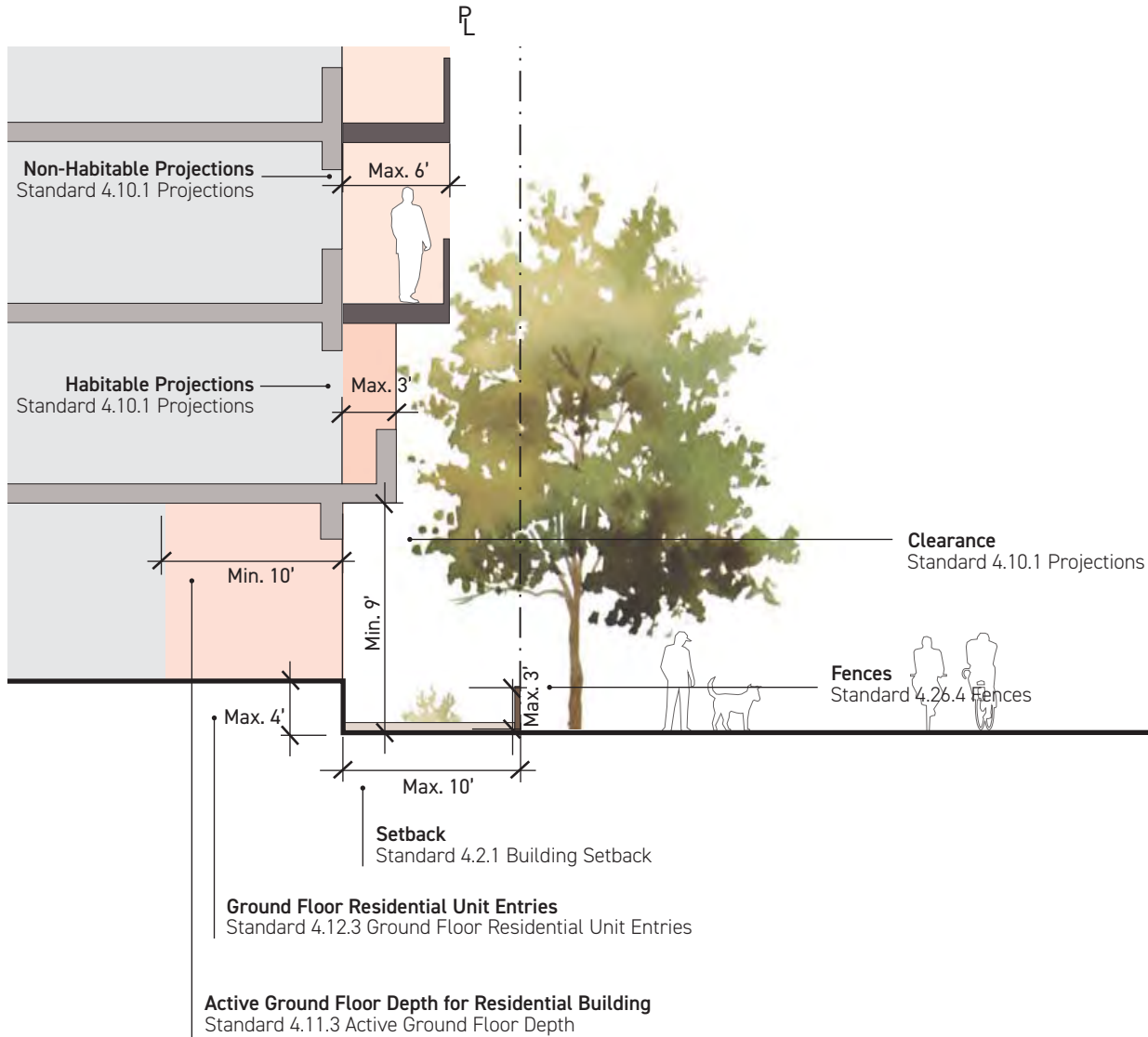

Figure 4.26e: SETBACK ZONE 4 (0' MIN./10' MAX.)



4.26 Private Open Space Cont'd

Setback Zone 5 - Refer to Page 56 for Setback requirements

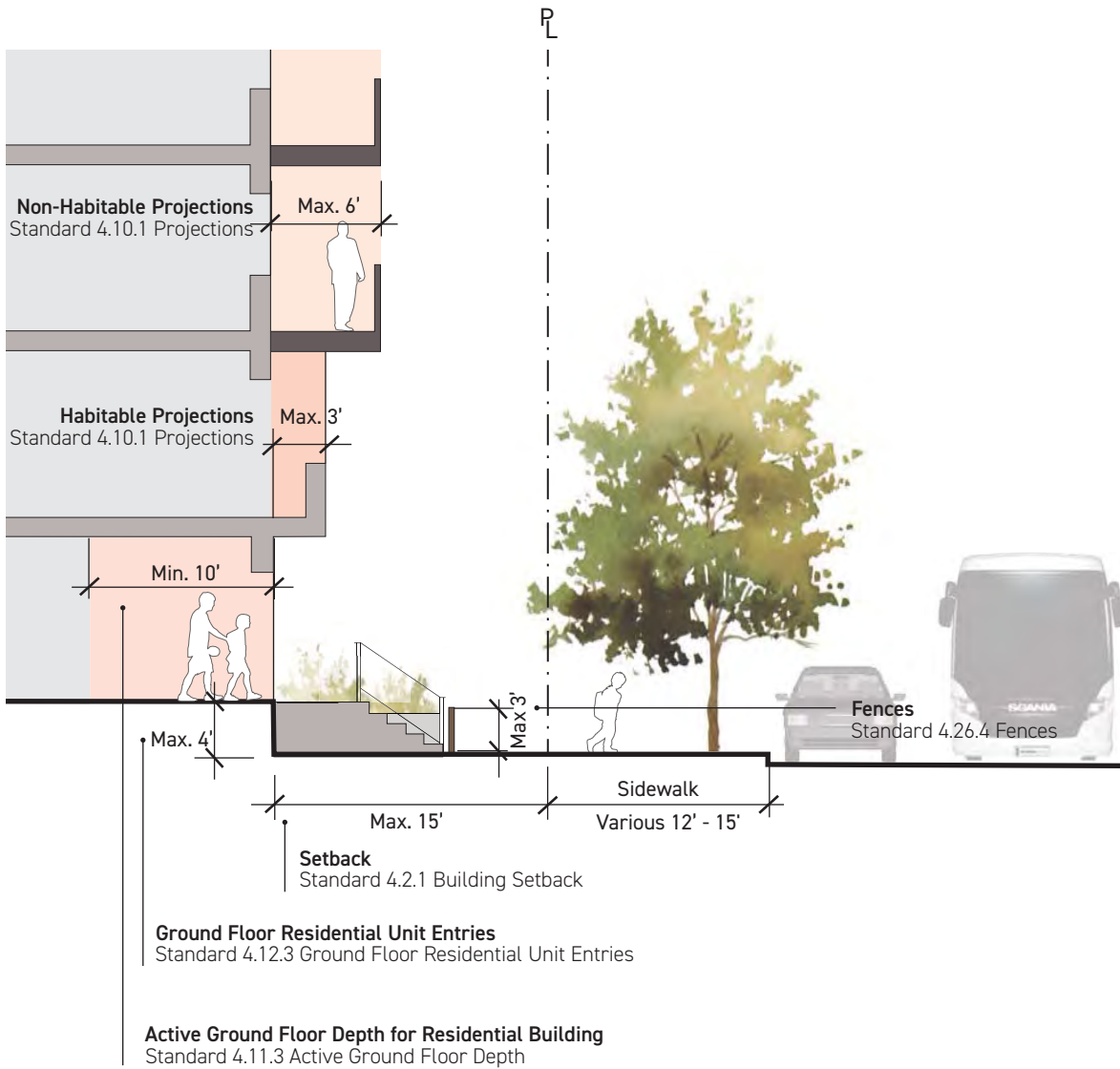

Figure 4.26f: SETBACK ZONE 5 (10' MIN./15' MAX.)



4.26 Private Open Space Cont'd

Setback Zone 6 - Refer to Page 56 for Setback requirements

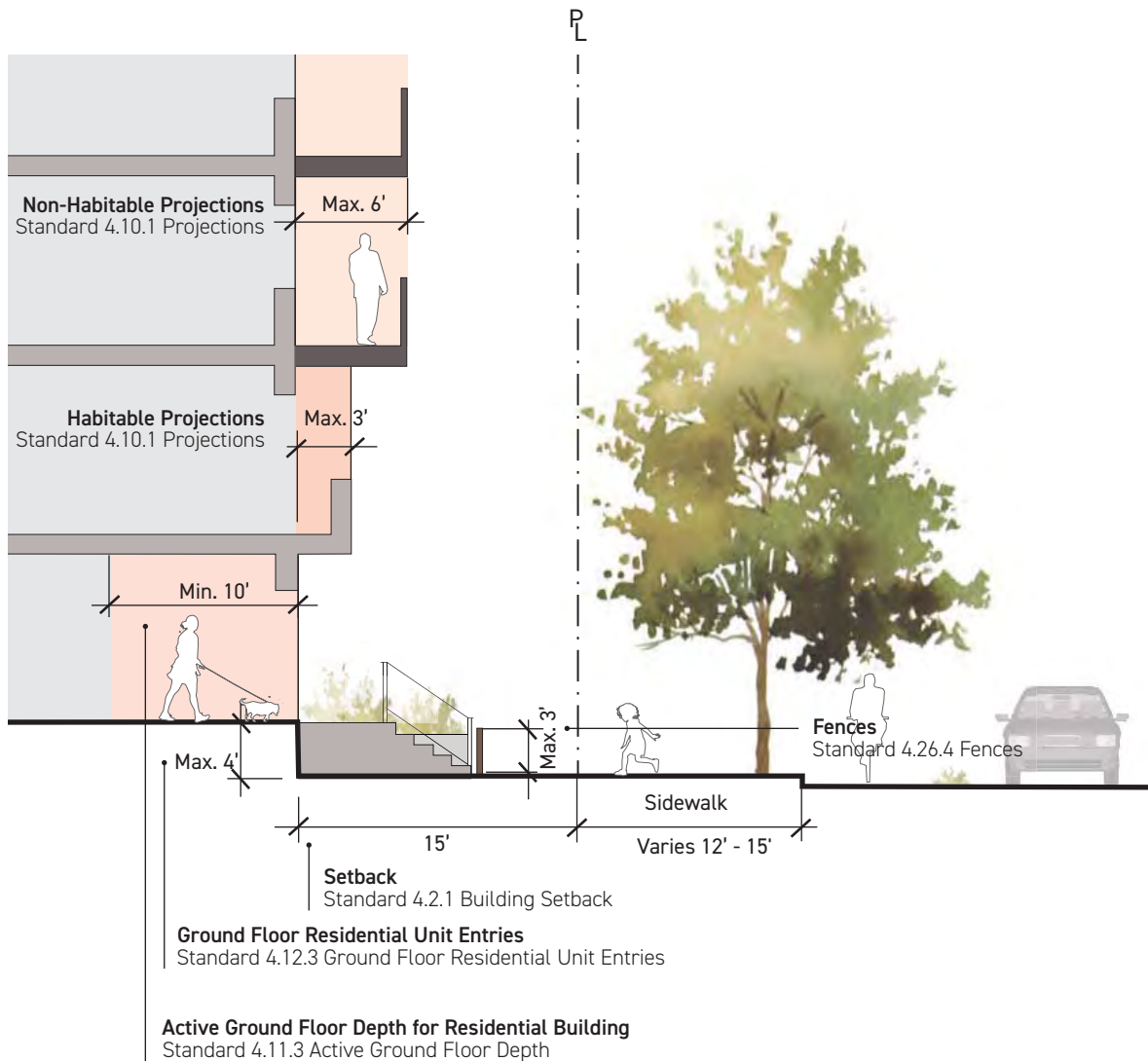
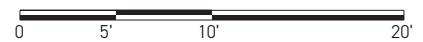

Figure 4.26g: SETBACK ZONE 6 (15' MIN./15' MAX.)



This page is intentionally left blank.

4.27 Private Open Space - Mid-Block Breaks

- 4.27.1 Public Access
- 4.27.2 Throughway Dimensions
- 4.27.3 Surfaces
- 4.27.4 Street Trees
- 4.27.5 Lighting

INTENT

Mid-Block Breaks (MBBs) are intended to allow public access through private development blocks to promote connectivity and walkability and create a finer grain circulation system.

MBBs are regulated by the CPHPS2 Infrastructure Plan, Transportation Plan, and Streetscape Master Plan.

Block sizes may be legal parcels or may be part of a legal parcel.

Mid-Block Break Specification Book will be provided per the DRDAP.

Residential Mid-Block-Breaks

Residential Mid-Block-Breaks will be domestic in character with defined transition zones between the public throughway and the Ground Floor residential units and amenity spaces. Residential Mid-Block Breaks may accommodate pedestrian, bicycle and low-volume vehicular access. The design will prioritize pedestrian access and safety, incorporate traffic-calming design elements and other Public Realm amenities. Residential spaces such as terraces, Stoops, or porches may spill into landscaped Setback zones. Ground Floor residential units will be slightly raised above-grade, to allow for privacy and Stoops, while access to ground-floor amenity spaces may further activate the Mid-Block Break and provide 'eyes on the street'.

Commercial Mid-Block-Breaks

Commercial Mid-Block-Breaks will be more public in nature and framed by uses such as Ground Floor retail storefronts, office and amenity spaces. Commercial Mid-Block Breaks may accommodate pedestrian, bicycle and low-volume vehicular access. The design will prioritize pedestrian access and safety, incorporate traffic-calming design elements and other public realm amenities. Interior active uses such as workspaces and restaurant seating may spill out into the Mid-Block Breaks. Landscape plantings, furnishings, gathering spaces and other design elements may serve as visual cues to differentiate pedestrian-dedicated areas from shared pedestrian or vehicular zones.

STANDARDS

4.27.1 Public Access

Mid-Block Breaks shall have unrestricted public access.

4.27.2 Throughway Dimensions

All Mid-Block Breaks shall have a pedestrian path with a minimum dimensions of ten[10] ft. in width. The access may be configured as two five[5] foot paths on either side of the Mid-Block Break or as one ten[10] foot path. A pedestrian path may be shared with bicycles and vehicles.

4.27.3 Surfaces

Hardscape surfaces within the MBB Width including throughway and landscape zones/Setback zones shall be limited to 80% of the ground plane.

4.27.4 Street Trees

A double row of street trees shall be planted at a spacing that is not greater than [30] ft. on center. Tree planters should be a minimum of [28] sq. ft. in size each. Trees may be located in the Mid-Block Break or in private Setback zones.

4.27.5 Lighting

Adequate lighting shall be provided to ensure pedestrian and vehicular safety and may be located in the Mid-Block Break or in the Setback zones.

4.27 Private Open Space - Mid-Block Breaks **Cont'd**

- 4.27.6 Community Spaces
- 4.27.7 Landscaping
- 4.27.8 Minimizing Vehicular Speeds

GUIDELINES

4.27.6 Community Spaces

Social spaces, seating and places for informal play are encouraged and may be located in the Mid-Block Break or in the Setback zones.

4.27.7 Landscaping

All Mid-Block Breaks are intended to be an outdoor room. Rich landscaping is encouraged so the drive aisle (in the case of a vehicular lane way) is subordinate. This includes street trees, shrub beds, patios and steps, benches, and lighting. Landscape planters can be raised or at grade based on architectural design. Landscaping may be located in the Mid-Block Break or in the Setback zones.

4.27.8 Minimizing Vehicular Speeds

Features to reduce vehicle speeds are encouraged, such as narrow drive aisle and offsets in the drive aisle alignment.

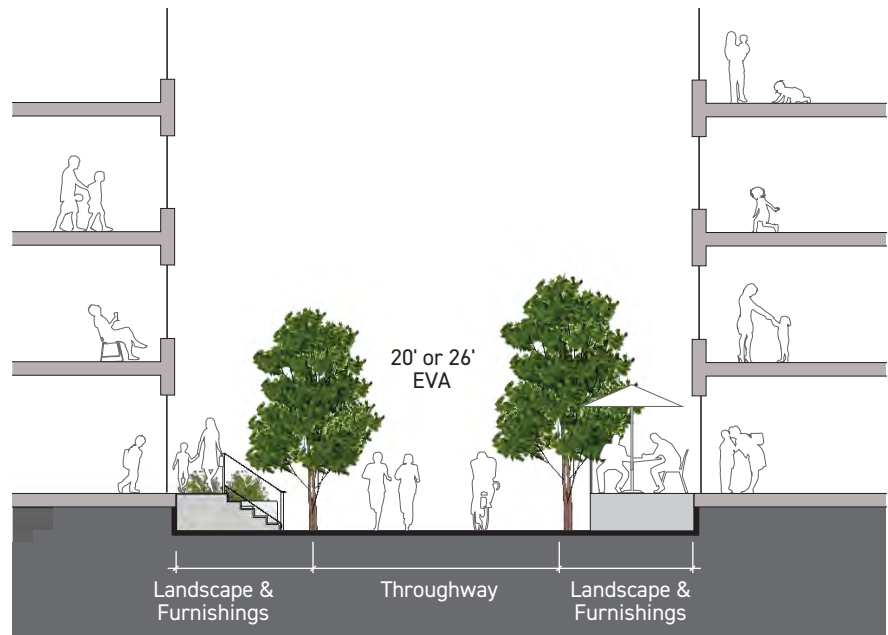

Figure 4.27a: RESIDENTIAL MID-BLOCK BREAK

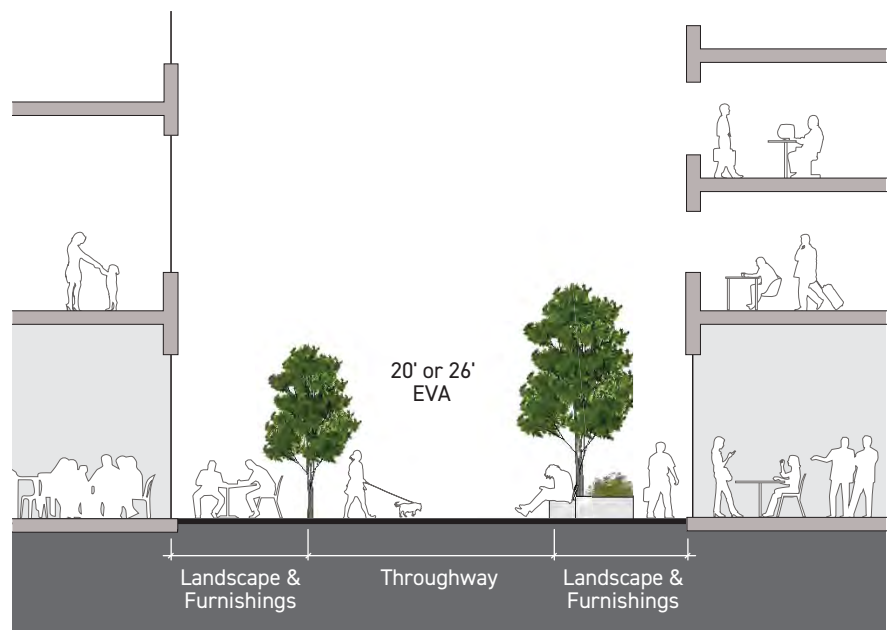

Figure 4.27b: COMMERCIAL MID-BLOCK BREAK

4.28 Building Signage

DEFINITIONS

"Sign"

Any structure, part thereof, or device or inscription which is located upon, attached to, or painted, projected or represented on any land or right-of-way; or on the outside of any building or structure including an Awning, Canopy, marquee or similar appendage; or affixed to the glass on the outside or inside of a window so as to be seen from the outside of the building, and which displays or includes any numeral, letter, word, model, banner, emblem, insignia, symbol, device, light, trademark, or other representation used as, or in the nature of, an announcement, advertisement, attention-arrester, direction, warning, or designation by or of any person, firm, group, organization, place, commodity, product, service, business, profession, enterprise or industry.

Two or more Sign faces shall be deemed to be a single Sign if such faces are contiguous on the same plane, or are placed back to back to form a single structure and are at no point more than two[2] ft. from one another. Also, on Awnings or marquees, two[2] or more faces shall be deemed to be a single Sign if such faces are on the same Awning or marquee structure.

"Business/Retail Signage"

A Sign which directs attention to the primary business, commodity, service, industry or other activity which is sold, offered, or conducted on the premises upon which the Sign is located or to which it is affixed. Where a number of businesses, services, industries or other activities are conducted on the premises, or a number of commodities, services, or other activities with different brand names or symbols are sold on the premises that one or more of those businesses, commodities, services, industries or other activities by brand name or symbol as an accessory function of the business Sign, provided that such advertising is integrated with the remainder of the business Sign, and provided also that any limits which may be imposed by the following standards on the area of the individual Signs and the area of the Signs on the property are not exceeded. The primary business, commodity, service, industry or other activity on the premises shall mean the use which occupies the greatest area of the premises upon which the business Sign is located, or to which it is affixed.

SIGN TYPES

Sign types for HPS2 are divided into two[2] general categories: Permanent Signs and Temporary Signs.

Permanent Signs

- Building Wall Signs
- Projecting or Blade Signs
- Canopy or Awning Signs
- Window Signs
- Street or Unit Address Signs
- Identifying Signs
- Freestanding or Directional Signs

Temporary Signs

- Temporary Signs
- Portable Signs

1. Hand-painted Wall Graphics Example
- 2 & 5-8. Building Wall Signs Example
3. Temporary Graphics and Signs Example
4. Awning Signs Example
9. Canopy Signs Example
10. Projecting or Blade Signs Example
11. Window Signs Example
- 12 & 13. Street and Unit Address Signs Example
14. Directional Signs Example
15. Identifying & Freestanding Signs Example
16. Directional Signs Example & Freestanding Signs Example

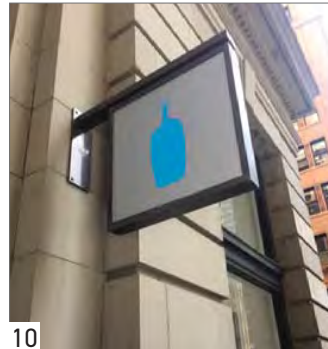
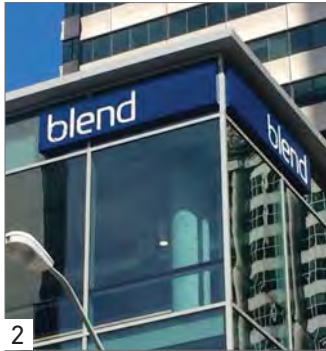
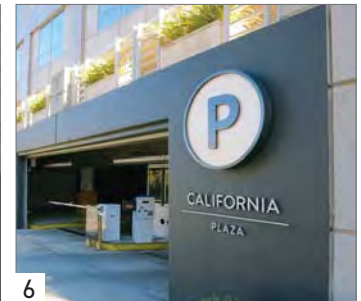

4.29 All Signs

- 4.29.1 Transparency
- 4.29.2 Concealed Electrical Signage Elements
- 4.29.3 Typefaces & Colors
- 4.29.4 Sign Materials
- 4.29.5 Graphic Style
- 4.29.6 Integration

STANDARDS

4.29.1 Transparency

Window signage shall not diminish transparency for the area of the Sign. Where window Signs are used, they shall maintain a high degree of visibility between interior and exterior spaces.

4.29.2 Concealed Electrical Signage Elements

All electrical signage elements such as wires, exposed conduit, junction boxes, transformers, ballasts, switches, and panel boxes shall be concealed from view.

4.29.3 Typefaces & Colors

Sign typefaces shall be legible to approaching vehicles and pedestrians and of a scale that is appropriate with the neighboring buildings, allowing for larger formats in more urban or retail-oriented areas and smaller formats on residential neighborhood streets. Tenants may use their type style and brand on signage.

4.29.4 Sign Materials

High quality materials, workmanship and detailing are encouraged in the design of building Signs. Sign materials and overall scale shall be complimentary to the buildings' architectural materials and thoughtfully integrated into the building's wall detailing and fenestration. Sign materials shall be selected that are durable and weather resistant and appropriate for the marine environment typical of the site. Where window Signs are used, Sign materials shall maintain a high degree of transparency, avoiding large opaque shapes. Refer to FC4- Façade Composition - Material/Color for building materials palette reference examples.

4.29.5 Graphic Style

Visually representational Signs with a creative graphic or iconic character are encouraged to allow for clearer interpretation and a variety of graphic styles. Wall Signs are encouraged to employ individual, dimensional pan-channel lettering and/or logos. Cabinet Signs shall be allowed, but only where integral to the tenant's identity.

4.29.6 Integration

Signage shall be appropriate to the District's buildings and streetscapes; designed to relate to use, composition, scale, and architecture. Signage shall be considered an important architectural and artistic feature within the overall building design.

4.29 All Signs Cont'd

4.29.7 New Technology Signs
4.29.8 Sign Illumination

STANDARDS

4.29.7 New Technology Signs

Signage using new forms of technology, such as dynamic content Signs, digital displays, or light projections may be appropriate where it is integrated into the building façade or behind the window glass. The displays shall be designed, located, oriented, and operated in a manner that has no adverse safety impacts.

Restrictions on New Technology Signs may include, but are not limited to:

- Large format digital displays that may be considered "digital billboards".
 - Limiting the hours of operation of the electronic Sign, generally between 5 am and midnight.
 - Limiting the amount and frequency of animation, or ensuring the content on dynamic content or digital Signs has a minimum dwell time and transition time of [15] seconds.
 - Limiting Sign brightness.
 - Locating the Sign inside a business premises and set back from window glazing.
 - Orienting the face of the Sign away from the adjoining street network and away from residential buildings / neighborhoods or facing the Green Room or the Bay.
- No flashing Signs.

4.29.8 Sign Illumination

Building wall, window or projecting Sign lighting may be externally or internally illuminated. Freestanding Sign types may be externally or internally illuminated; or during business hours, directly illuminated. However, cabinet Signs with internally face-lit plastic Sign faces are prohibited.

The amount of Sign illumination hours per day shall be limited to normal business hours, except as noted for electronic Signs.

Decorative, external light source fixtures are encouraged for externally illuminated Signs. However, junction boxes, tubing, conduits and raceways shall be concealed or incorporated into the design of the Sign structure to the greatest extent possible. No exposed LED, neon or other lighting sources is allowed.

1. Digital Display Sign

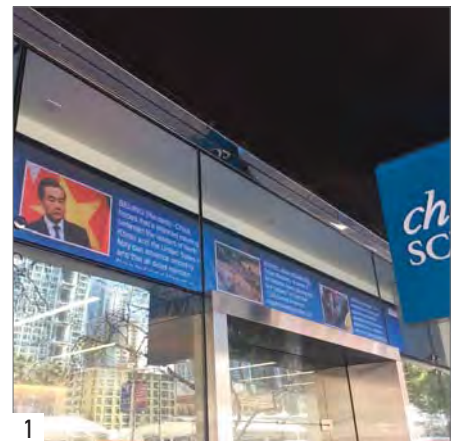

4.29 All Signs Cont'd

4.29.9 Prohibited Signage

STANDARDS

4.29.9 Prohibited Signage

The following types of Signs and Sign conditions are not permitted:

- Signs attached to a building that extend or are located above the roof line of the building to which it is attached
- Wind Signs which are composed of one or more banners, flags, or other objects, except official City, State or Federal flags, mounted serially and fastened in such a manner as to move upon being subjected to pressure by wind
- Revolving Signs which rotate or spin
- Blinking or flashing Signs which exhibit rapidly changing levels of illumination
- Balloon or inflated Signs constructed of materials supported by inflated means
- Billboards, specifically a large graphic panel designed to carry outside advertising
- Posters or handbills of a temporary nature not contained in a designated wall-mounted or freestanding poster case or display fixture
- Signs that obstruct the passage or sight lines of motorists, bicyclists or pedestrians
- Signs that replicate, mimic or could be mistaken as a traffic control device
- Signs with mirror-reflective materials, colors or finishes. Reflective materials exclude LED signs behind glass
- Signs with sound, vibration, odor or other emissions, unless the emission is necessary as part of a community message or to meet applicable disability standards
- Video, moving or flashing Signs
- Exposed LED or neon Signs

4.30 Permanent Signs

4.30.1 Commercial Wall Signage

INTENT

Wall Signs utilizing the building structure as a mounting surface.

DEFINITIONS

"Wall Sign"

A Sign painted directly on the wall or mounted flat against a building wall with its copy or graphics parallel to the wall to which it is attached and not protruding more than the thickness of the Sign.

"Sign Area"

Sign Area is defined as the area of a Sign that is used for display purposes. Sign Area shall be calculated by measuring the size of a rectangle large enough to contain the entire Sign's display, graphics, and text that form an integral part of the display or are used to differentiate such Sign from the background against which it is placed. The calculation of Sign Area excludes the necessary supports or uprights on which such Sign is placed.

STANDARDS

4.30.1 Commercial Wall Signage

Commercial wall signage is used to highlight the building name, district identity, or primary tenant.

One[1] commercial Wall Sign is allowed for each building façade.

For commercial Wall Signs, the maximum height of a Sign affixed to a building shall be [24] ft. from sidewalk grade.

The area of all commercial building Wall Signs shall not exceed [125] sq. ft. for each building frontage. In no case shall any one[1] Wall Sign be taller than five[5] ft. in height.

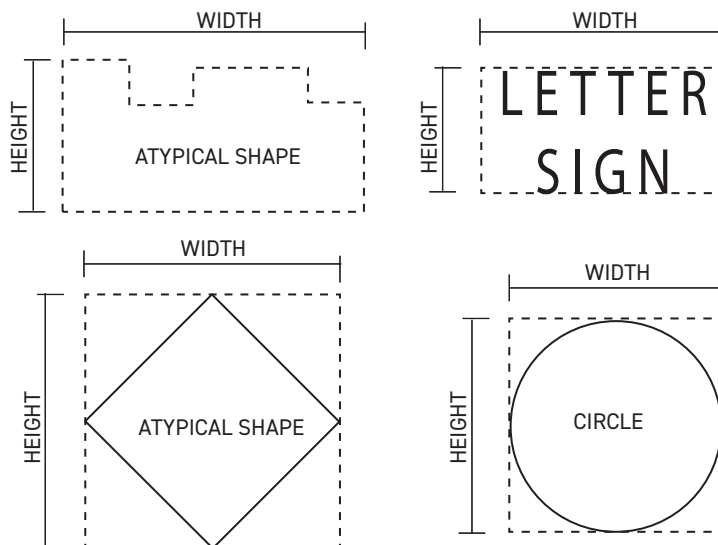

Figure 4.30a: SIGN AREA CALCULATION DIAGRAM

4.30 Permanent Signs Cont'd

- 4.30.2 Storefront and Retail Wall Signage
- 4.30.3 Residential Wall Signage

STANDARDS

4.30.2 Storefront and Retail Wall Signage

No more than two[2] Wall Signs per single-tenant retail space are permitted. If a single-tenant retail space has more than one[1] street frontage, an additional Sign beyond the two[2] allowed on the main frontage is permitted on each additional frontage.

The area of all storefront or retail tenant Wall Signs shall not exceed two[2] sq. ft. for each one[1] linear ft. of street frontage occupied by the business measured along the wall to which the Signs are attached, or up to [100] sq. ft. for each street frontage, whichever is less. In no case shall the Wall Sign or combination of Wall Signs cover more than 50% of the surface of any wall, excluding openings.

The maximum height of a storefront or retail Sign affixed to a building shall be the bottom of the window sill of the first story, or [24] ft., whichever is lower.

4.30.3 Residential Wall Signage

Residential Wall Signs shall not exceed [20] sq. ft. total, except for Wall Signs providing the primary identification of multi-unit residential buildings, which shall not exceed [25] sq. ft. and one[1]ft. in height and shall be located at the building entrance, or up to [100] sq. ft. for each building frontage, whichever is less.

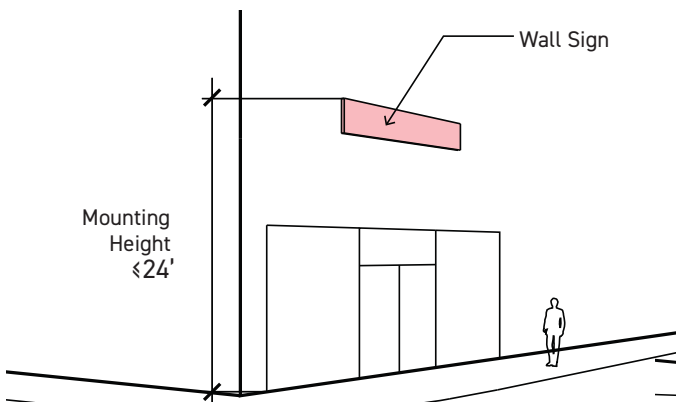

Figure 4.30b: BUILDING WALL SIGN

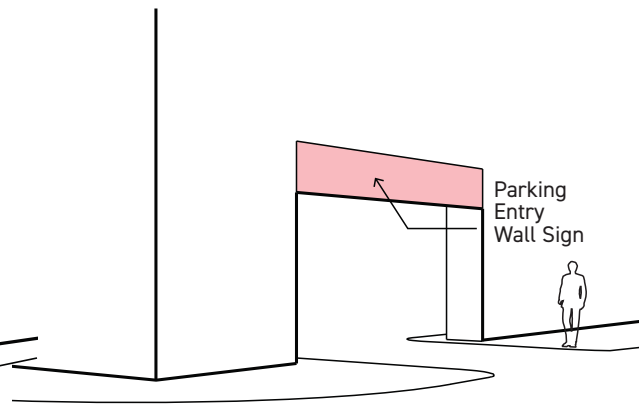

Figure 4.30c: ENTRY WALL SIGN

4.30 Permanent Signs Cont'd

4.30.4 Projecting Signs

INTENT

Projecting Signs are attached to a building and project perpendicularly from the mounting surface. They are intended to provide long distance visibility to approaching vehicles and pedestrians.

DEFINITIONS

"Projection"

The horizontal distance by which the furthest point used in measuring the area of a Sign extends beyond a Street Property Line or a building Setback line.

STANDARDS

4.30.4 Projecting Signs

No part of a Projecting Sign shall project more than 75% of the horizontal distance from the Property Line to the curb line, or six[6] ft. six[6] in. from face of building, whichever is less. One[1] Projecting Sign is allowed per Ground Floor business and shall not exceed [24] sq. ft. in area. Corner businesses are allowed one[1] primary Projecting Sign per street frontage. Projecting Signs for retail tenants shall be attached below the second floor window sill level.

The height of a Projecting Sign shall not exceed [24] ft., or the height of the wall to which it is attached, or the height of the lowest of any residential windowsill on the wall to which it is attached, whichever is lowest, but bottom of Sign shall be least ten[10] ft. above sidewalk grade. Text shall be no greater than one[1] ft. in height.

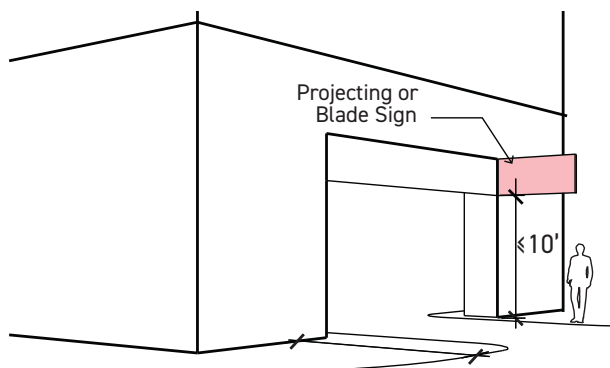

Figure 4.30d: PROJECTING SIGN

4.30 Permanent Signs Cont'd

4.30.5 Window Signs

INTENT

Window Signs provide messaging on, or behind, window glazing at building frontages.

DEFINITIONS

"Window Sign"

A Sign painted or applied directly on the surface of a window glass or placed behind the surface of a window glass.

STANDARDS

4.30.5 Window Signs

Window Signs applied to building glazing shall not cover more than a maximum of 30% of the storefront glazing area. Glazing transparency shall be maintained within the window graphics zone, avoiding large opaque shapes or materials.

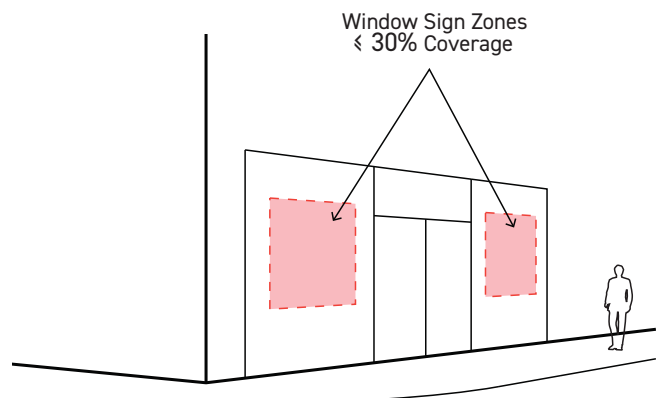

Figure 4.30e: WINDOW SIGNS

4.30 Permanent Signs Cont'd

4.30.6 Identifying, Freestanding, or Directional Signs

INTENT

Identifying Signs serve as the primary project or parcel identification, and are placed at the primary district entry points.

A Freestanding Sign is permitted in lieu of a Projecting Sign, if the building or buildings are recessed from the Street Property Line.

DEFINITIONS

"Freestanding & Directional"

Signs detached from the building and in no part supported by the building providing identification, information or direction to a building or group of buildings.

STANDARDS

4.30.6 Identifying, Freestanding, or Directional Signs

The maximum height for free-standing or Identifying Signs shall not exceed [12] ft., nor exceed [24] sq. ft. in total area. The existence of a Freestanding business Sign will preclude the placement of a Freestanding Identifying Sign on the same lot.

The location of pedestrian Directional Signs associated with a building or group of buildings shall not exceed a maximum height of eight[8] ft., nor more than [12] sq. ft. in total area.

Freestanding or Identifying Signs shall be limited to the Setback zone.

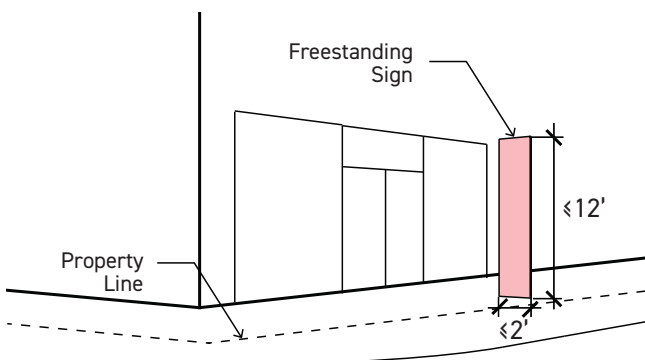

Figure 4.30f: FREESTANDING SIGNS

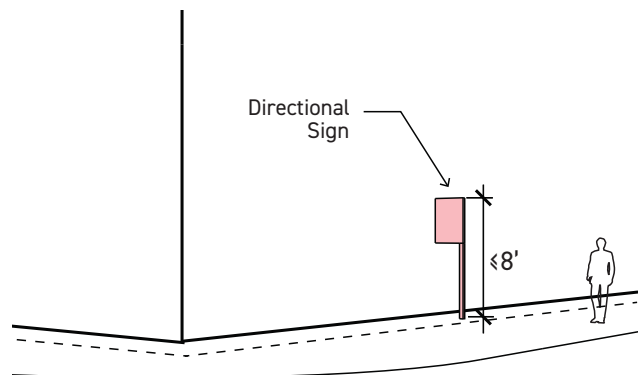

Figure 4.30g: DIRECTIONAL SIGNS

4.30 Permanent Signs Cont'd

4.30.7 Canopy/Awning Signage

INTENT

Signage or graphics messaging applied to an awning or projecting canopy structure in lieu of Projecting Signs.

DEFINITIONS

"Awning"

A light roof-like structure, supported entirely by the exterior wall of a building, consisting of a moveable frame covered with approved materials, extending over doors and windows, with the purpose of providing protection from sun and rain and embellishment of the façade.

"Canopy"

A light roof-like structure, supported by the exterior of a building, consisting of a fixed or frame covered with approved cloth, plastic or metal, with the purpose of providing protection from sun and rain and embellishment of the façade.

STANDARDS

4.30.7 Canopy/Awning Signage

Any signage on projecting building Awnings or Canopies shall not exceed a total of [24] sq. ft.. Residential projects may utilize signage on Awnings over the primary multi-unit entryway. Awning or Canopy Sign copy shall be non illuminated ,constructed of metal or fabric covered metal frame.

The bottom of any Awning or Canopy Sign shall be at least ten[10] ft. above finished grade.

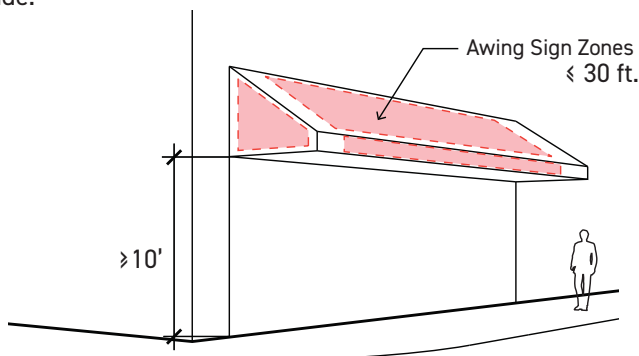

Figure 4.30h: AWNING SIGNS ZONES

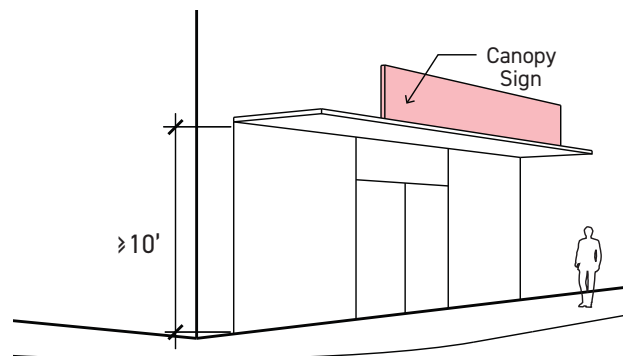

Figure 4.30i: CANOPY SIGNS

4.30 Permanent Signs Cont'd

4.30.8 Street or Unit Address Signs, Nameplates

INTENT

Street address or unit address signs provide address identification visible from streets and walkways. Nameplate Signs designate the names or individual name and professional occupations of persons in a building.

STANDARDS

4.30.8 Street or Unit Address Signs, Nameplates

Street address or unit identification applied to the building at entries shall be clearly visible from street, and shall comply with San Francisco Fire Department requirements, and shall not exceed eight[8] sq. ft. in total area. Nameplate Signs also shall be associated with the building wall adjacent to building entries, and shall not exceed two[2] sq. ft. in total area.

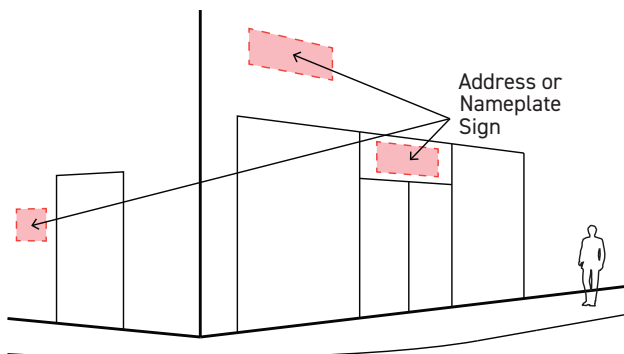

Figure 4.30j: ADDRESS OR NAMEPLATE SIGNS

4.31 Temporary Signs

4.31.1 Temporary Signs

INTENT

Freestanding, window-mounted, wall-mounted or barricade graphics or signage intended to be temporary in nature and duration.

STANDARDS

4.31.1 Temporary Signs

Temporary, freestanding Signs shall not exceed [12] ft. in height, nor exceed a total area of [50] sq. ft.

Temporary construction project identification Signs or graphics shall not exceed [500] sq. ft. and shall be removed within seven[7] days of contract completion. Project signage is limited to one[1] Sign per frontage. Where there is more than one entity (e.g. general contractor, architect, broker etc.), a single project Sign shall be used, stating the name and contact information of all entities. Opaque storefront signage or coverings used during construction at Ground Floor storefronts such as applied film or other temporary window obscuring techniques are allowed while spaces remain unoccupied.

Temporary signage areas/applications shall be maintained free of posters, graffiti and in an otherwise presentable manner.

Temporary construction safety fencing, barricades or scaffolding are allowed to be covered with construction wrap/super graphics. Construction wrap/super graphics are allowed placed along the full length of temporary safety fencing or scaffolding up to [12] ft. high, but shall not restrict or obstruct vehicular or pedestrian access to the construction site, or information required to be publicly displayed, including but not limited to contractor contact information, regulatory and directional signage.

Construction wrap shall not be affixed to a fence, barricade or scaffolding unless the fence, barricade and/or scaffolding is constructed to withstand the consequence of wind and other loads.

All construction wrap/super graphics shall bear the name of the installer and a local or toll-free phone number, labeled "Service Number", located on the face on the wrap at a minimum size of two[2] in., where citizens may contact or leave word for the installer of the banner regarding maintenance or repair problems.



1

1. Temporary Signs Example

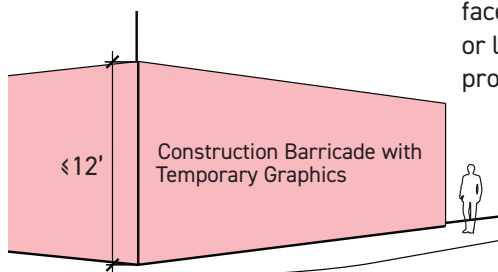

Figure 4.31a: TEMPORARY BARRICADE GRAPHICS ZONES

4.31 Temporary Signs Cont'd

4.31.2 Portable Signs

INTENT

Portable Signs are movable Sign units placed adjacent to the business or tenant entry or frontage.

DEFINITIONS

"Portable"

Signs which are freestanding, movable and not permanently anchored or attached to the ground.

STANDARDS

4.31.2 Portable Signs

Portable Signs, such as sandwich boards, "A frames" or similar temporary Sign structures, are permitted and limited to no more than one[1] per business. All Portable Signage shall be located within frontage or furnishing zones not to exceed [20] ft. wide on sidewalks, or within open spaces fronting the businesses. Portable Signage shall not exceed five[5] ft. in height, nor be larger than ten[10] sq. ft. in area.

Portable Signs shall be sited so as to not obstruct the passage or sight lines of motorists, bicyclists or pedestrians.



1

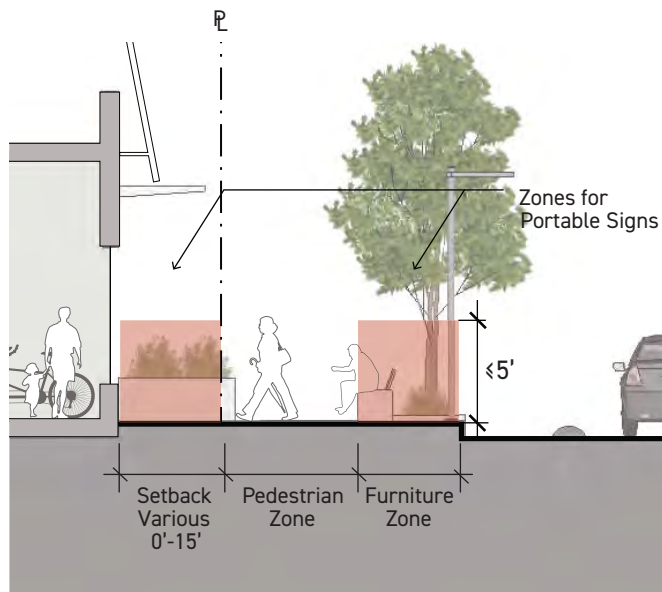

1. Portable Signs Example *Figure 4.31b: PORTABLE SIGNS PLACEMENT ZONES*

4.32 Building Lighting

- 4.32.1 Glare Reduction
- 4.32.2 Energy Consumption

INTENT

Building designs are encouraged to use lighting in innovative and engaging ways to create an attractive and secure environment, both during the day and at night. However, lighting shall not dominate the urban character of the neighborhood. Lighting shall be integrated with the design of the building, in harmony with building architecture, highlighting significant architectural features where appropriate; such as Signs, entrances, walkways, or display windows.

GUIDELINES

4.32.1 Glare Reduction

Lighting shall be designed to minimize glare and light trespass into neighboring buildings.

4.32.2 Energy Consumption

Smart lighting technology shall be incorporated where feasible or practical, such as those with automated controls that adjust based on occupancy or daylight availability, or use motion sensors. High-efficiency technology such as LED lighting with advanced controls, shall be utilized to minimize energy consumption.

4.32 Building Lighting Cont'd

- 4.32.3 Building Entrances
- 4.32.4 Dark Sky
- 4.32.5 Dark Sky Exception

STANDARDS

4.32.3 Building Entrances

Lighting at Building Entrances shall be provided for security. Pedestrian paths into and around the ground floor and stairways linking parking structures to public ways of the parking structure shall be well-lit at night.

GUIDELINES

4.32.4 Dark Sky

Lighting shall be shielded to prevent light from emitting above a 90-degree angle. Any lighting source located on rooftop parking shall be a full cutoff type.

4.32.5 Dark Sky Exception

Temporary accent lighting may be appropriate to create art, illuminate art, or highlight architectural features.



1



2

1. & 2. Entrances and Ground Level Lighting Examples

4.33 Private Infrastructure

4.33.1 Odor Control at the Recycled Water Facility

4.33.2 Screening of Eco-District or Eco-Grid Utilities Visible at Grade

INTENT

To implement odor control methods at the Recycled Water Treatment Facility and screening controls for above grade infrastructure on private property to mitigate any adverse impacts of utilities and equipment on the public realm.

GUIDELINES

4.33.1 Odor Control at the Recycled Water Facility

If the recycled water facility is constructed, the facility's odor control methods identified in the supporting environmental analysis will be implemented.

Odor control methods could include enclosed and covered process tanks, a suction blower to capture air from one or more unit processes, a scrubber system, and the off-site processing of sludge.

The operator shall post a telephone number in a conspicuous place at the facility to accept odor complaints, and in the highly unlikely event that the facility develops an odor issue, the existing odor control measures will be repaired or maintained, or additional odor control measures will be implemented until the odor issue is completely addressed.

4.33.2 Screening of Eco-District or Eco-Grid Utilities Visible at Grade

Enclosure or Screening shall be designed as a logical extension of and/or compatible with the adjacent building and an integral part of the overall building design. Screening material and detailing shall be comparable in quality to that of the rest of the building. Landscaping alone shall not qualify as Screening of at-grade utilities.

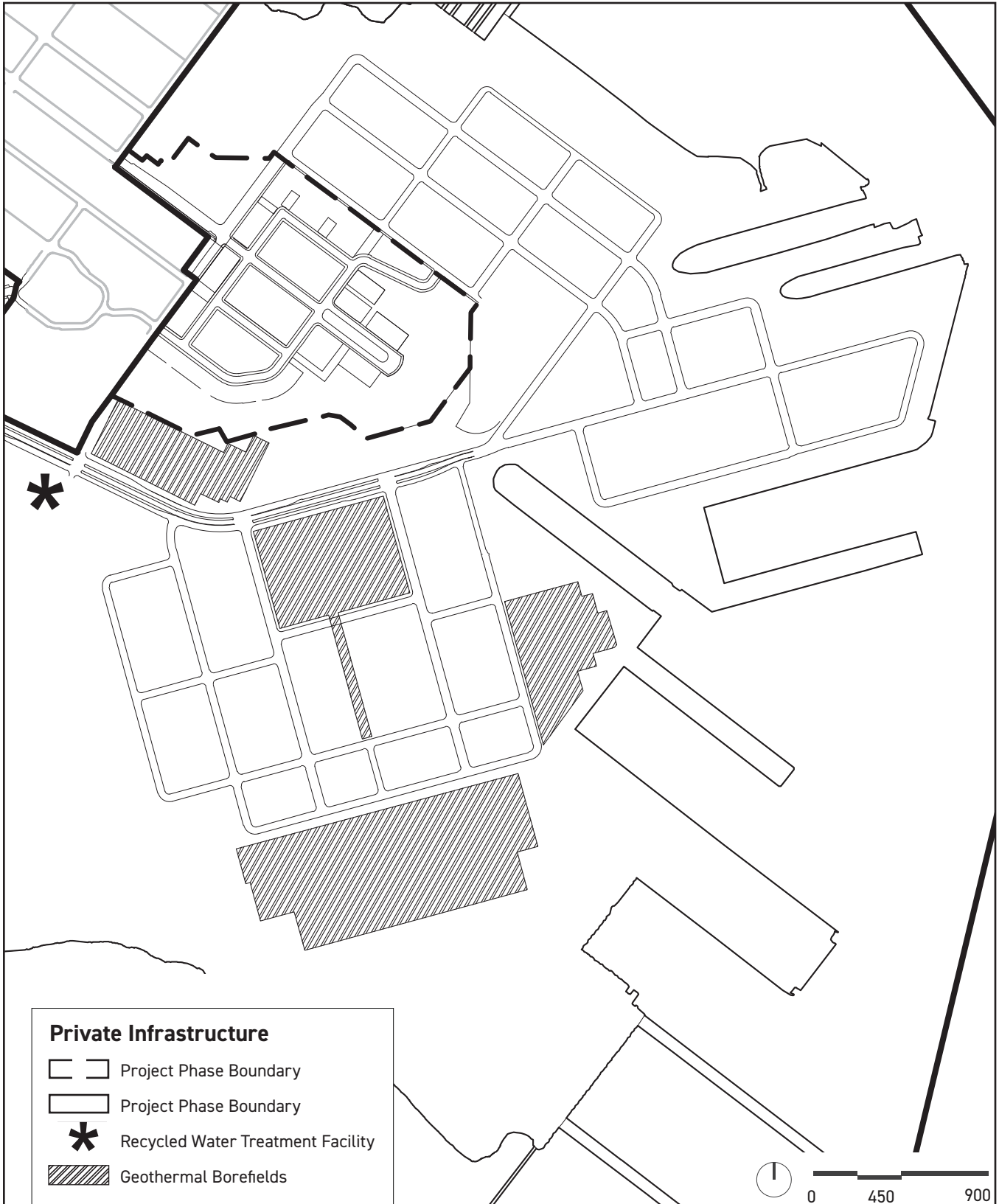

Figure 4.33a: PRIVATE INFRASTRUCTURE

5 IMPLEMENTATION

5.1	Review & Approval of Design Documents	167
5.2	Deviations and Variances	168
5.3	Process for Amendment of the Design for Development Documents	169

5 | Implementation

5.1 Review and Approval of Design Documents

The Design Review and Document Approval Procedures (DRDAP) establishes the processes by which applications for approvals are to be submitted and subsequently reviewed by the Commission of the Office of Community Investment and Infrastructure (OCII). Specific to the D4D, the DRDAP further establishes the processes and time lines for OCII review of architectural and design documents– including Schematic Design, Design Development and Construction Documents – for various improvements within the Shipyard that are subject to the Disposition and Development Agreement or Owner Participation Agreement.

The OCII and City agencies having jurisdiction have entered into an Interagency Cooperation Agreement that sets forth the City agencies' obligations in connection with review and approval of applications pursuant to the DRDAP, as well as review and approval of various permits, subdivision maps, and other authorizations required from the City.

As provided in the Shipyard Plan, OCII review of any application relating to development within the Shipyard shall be evaluated for consistency with the allowable land use set forth in the HPS Redevelopment Plan and in this Design for Development document.

5.2 Deviations and Variances

The owner of any property that is subject to this Design for Development document may make a written request for either a deviation or a variance from the design standards or any other provision of this document. A deviation is a minor modification no greater than ten[10] percent of a dimensional or numerical building standard. Only the following standards may be considered for a Deviation:

4.1.1	Block Sizes (dimensions only)	4.13.5	Parking and Service Entrances (dimensions only)
4.2.1	Building Setback	4.17.1	Ground Floor Blank Walls
4.4.4	Roof Area Building Height Exception	4.17.2	Upper Floor Blank Walls
4.4.5	Street Wall Requirement (Required Percentage of Build-up Only)	4.18.2	Commercial Daylight
4.10.1	Projections	4.22.1	Skyway Connections (dimensions only)
BM1	Significant Building Breaks (dimensions only)	4.23.1	Green Room Datum
BM2	Upper Floor Stepbacks (dimensions only)	4.26.1	Private Open Space
BM3	Façade Variation (dimensions only)	4.26.4	Fences
4.11.3	Active Ground Floor Depth	4.27.4	Street Trees
4.11.9	Active Use Ground Floor Transparency		
4.12.3	Ground Floor Residential Unit Entries		

Deviations must meet the purpose and intent statements of the Design for Development and may be authorized by the OCII Director. To the extent reasonably possible, proposed Deviations must be identified at the time of Schematic Design Document submittal pursuant to the DRDAP. The OCII Director's approval or disapproval of proposed Deviations shall be limited to a determination of its compliance with the Design for Development, the Redevelopment Plan and any applicable Redevelopment Requirements. Should a request for Deviation be made after OCII Commission approval of Schematic Design, the OCII Director, in her or his sole discretion, may seek comment and guidance from the public and OCII Commission on the granting of any deviations.

Variance decisions must be made by the OCII Commission. A request for a variance must state fully the grounds for the application and include relevant facts in support of the application. The OCII Commission may grant a variance from development controls under the following circumstances:

Due to unique physical constraints or other circumstances applicable to the property, the enforcement of development regulations would result in difficulties for the development and create undue hardship for the owner or developer, or would constitute an unreasonable limitation beyond the intent of the D4D; and

The effect of the variance would be in harmony with the goals of the D4D, and would not be materially detrimental to public welfare, neighboring property or nearby improvements.

The OCII Commission's decision to grant or deny a variance is final, and not appealable to either the San Francisco Planning Commission or the Board of Supervisors.

5.3 Process for Amendment of the Design for Development Document

D4D amendments require approval of both the San Francisco Planning Commission and the OCII Commission.

6 APPENDIX

6.1	Checklist	172
6.2	Building Design Application Studies	180
6.3	Sitewide Diagrams	190
6.4	Term Definitions	193
6.5	List of Figures	200
6.6	Image Credits	202

6.1 Checklist

Building Design

STANDARD	NOTES
<input type="checkbox"/> 4.1 Block Sizes and Mid-Block Breaks	
<input type="checkbox"/> 4.1.1 Mid-Block Break Locations	
<input type="checkbox"/> 4.2 Building Setback	
<input type="checkbox"/> 4.2.1 Building Setbacks	
<input type="checkbox"/> 4.2.2 Mid-Block Break Setback	
<input type="checkbox"/> 4.3 Developable Area Coverage	
<input type="checkbox"/> 4.3.1 Developable Area Coverage	
<input type="checkbox"/> 4.4 Building Height	
<input type="checkbox"/> 4.4.1 Building Height	
<input type="checkbox"/> 4.4.2 MBB Building Stepbacks	
<input type="checkbox"/> 4.4.3 Building Height Exceptions	
<input type="checkbox"/> 4.4.4 Roof Area Building Height Exception	
<input type="checkbox"/> 4.4.5 Street Wall	
<input type="checkbox"/> 4.4.6 Implied Façade	
<input type="checkbox"/> 4.4.7 Street Wall Exceptions for Adaptive Reuse	
<input type="checkbox"/> 4.4.8 Street Wall Exceptions for Recessed Areas	
<input type="checkbox"/> 4.5 Architectural Controls by Building Scale	
<input type="checkbox"/> 4.5.1 Architectural Controls by Building Scale	
<input type="checkbox"/> 4.5.2 Maximum Plan Length	
Flow Chart for Architectural Controls	
<input type="checkbox"/> 4.6 FC Façade Composition	
<input type="checkbox"/> 4.6.1 Façade Composition (FC)	
<input type="checkbox"/> 4.6.2 Block to Block Variation	
<input type="checkbox"/> FC1 Façade Modulation Strategies	
<input type="checkbox"/> FC2 Façade Articulation Strategies	
<input type="checkbox"/> FC3 Façade Fenestration Strategies	
<input type="checkbox"/> FC4 Material/Color Strategies	

STANDARD	NOTES
<input type="checkbox"/> 4.7 BM Bulk and Massing	
<input type="checkbox"/> 4.7.1 Bulk and Massing Approach	
<input type="checkbox"/> BM1 Significant Building Breaks	
<input type="checkbox"/> BM2 Upper Floor Stepbacks	
<input type="checkbox"/> BM3 Façade Variation (FV)	
<input type="checkbox"/> 4.8 BE/PE Building and Public Realm Enhancements	
<input type="checkbox"/> 4.8.1 Building and Public Realm Enhancement Measures for M, L, XL Buildings	
<input type="checkbox"/> BE1 Apply One[1] Additional Bulk/Massing Control	
<input type="checkbox"/> BE2A Orient Private Courtyards and/or Atria Onto a Public ROW or MBB (Per Street Fronting Elevation)	
<input type="checkbox"/> BE2B Orient Private Courtyards and/or Atria Onto a Public ROW or MBB (Multiple Street Fronting Elevations)	
<input type="checkbox"/> BE3 Provide Visual and Physical Access to Interior Courtyard and/or Atrium	
<input type="checkbox"/> BE4 24/7 Public Access to Open Space	
<input type="checkbox"/> BE5 Reduction in Floor Plate Area of Upper Floors	
<input type="checkbox"/> BE6 Expressive Entrances	
<input type="checkbox"/> BE7 Increased Transparency	
<input type="checkbox"/> BE8 Distinct Corner Architectural Feature	
<input type="checkbox"/> BE9 Roof Expression	
<input type="checkbox"/> BE10 Additional Active Entrances	
<input type="checkbox"/> BE11 Additional Ground Floor Activation	
<input type="checkbox"/> PE1 Public Access through the Building	
<input type="checkbox"/> PE2 Public Access through Open Space Connection	
<input type="checkbox"/> 4.9 Tower Controls	
<input type="checkbox"/> 4.9.1 Tower Locations	
<input type="checkbox"/> 4.9.2 Tower Floor Aspect Ratio	
<input type="checkbox"/> 4.9.3 Tower Height Variation	
<input type="checkbox"/> 4.9.4 Tower Massing and Articulation	
<input type="checkbox"/> 4.9.5 Tower Mechanical Equipment	
<input type="checkbox"/> 4.9.6 Tower Mechanical Equipment Screening	

6.2 Checklist cont'd

STANDARD	NOTES
<input type="checkbox"/> 4.10 Projections	
<input type="checkbox"/> 4.10.1 Projections	
<input type="checkbox"/> 4.10.2 Habitable Projections	
<input type="checkbox"/> 4.10.3 Non-Habitable Projections	
<input type="checkbox"/> 4.10.4 Other Projections	
<input type="checkbox"/> 4.10.5 Projection Exemptions	
<input type="checkbox"/> 4.10.6 Maximum Projection Area	
<input type="checkbox"/> 4.11 Ground Floor Activation	
<input type="checkbox"/> 4.11.1 Zone 1 and 2 Active Entrances	
<input type="checkbox"/> 4.11.2 Zone 3 Active Entrances	
<input type="checkbox"/> 4.11.3 Active Ground Floor Depth	
<input type="checkbox"/> 4.11.4 Ground Floor Height	
<input type="checkbox"/> 4.11.5 Waterfront Activation	
<input type="checkbox"/> 4.11.6 Guidelines for Ground Floor Residential Design	
<input type="checkbox"/> 4.11.7 Ground Floor Activation	
<input type="checkbox"/> 4.11.8 Shared Parking Structures Activation	
<input type="checkbox"/> 4.11.9 Ground Floor Active Use Transparency	
<input type="checkbox"/> 4.11.10 Ground Floor Active Use Glass and Glazing	
<input type="checkbox"/> 4.12 Building Entries	
<input type="checkbox"/> 4.12.1 Building Entries	
<input type="checkbox"/> 4.12.2 Green Room Building Entries	
<input type="checkbox"/> 4.12.3 Ground Floor Residential Unit Entries	
<input type="checkbox"/> 4.12.4 Building Entries	
<input type="checkbox"/> 4.12.5 Guidelines for Ground Floor Residential Design	
<input type="checkbox"/> 4.13 Parking and Service Entrances	
<input type="checkbox"/> 4.13.1 Parking and Service Entrances Locations	
<input type="checkbox"/> 4.13.2 Combined Parking and Service Entrances	
<input type="checkbox"/> 4.13.3 Separate Parking and Service Entrances	
<input type="checkbox"/> 4.13.4 Maximum Parking and Service Entrances	
<input type="checkbox"/> 4.13.5 Parking and Service Entrances	
<input type="checkbox"/> 4.13.6 Parking and Service Entrances (Blocks 38 & 45)	
<input type="checkbox"/> 4.13.7 Residential Mechanical Parking	

STANDARD	NOTES
<input type="checkbox"/> 4.14 Screening	
<input type="checkbox"/> 4.14.1 Screening	
<input type="checkbox"/> 4.14.2 Screening of Utilities Visible at Grade	
<input type="checkbox"/> 4.14.3 Screening Materials	
<input type="checkbox"/> 4.14.4 Screening for Rooftop Equipment	
<input type="checkbox"/> 4.14.5 Screening for Upper Floor Parking	
<input type="checkbox"/> 4.14.6 Screening for Ground Floor Parking	
<input type="checkbox"/> 4.14.7 Rooftop Screening for Parking	
<input type="checkbox"/> 4.15 Shared Parking Structures	
<input type="checkbox"/> 4.15.1 Shared Parking Structure Locations	
<input type="checkbox"/> 4.15.2 Number of Parking Structures	
<input type="checkbox"/> 4.15.3 Shared Parking Structure Design	
<input type="checkbox"/> 4.15.4 Convertible Shared Parking Structures	
<input type="checkbox"/> 4.15.5 Floor Heights for Convertible Shared Parking Structures	
<input type="checkbox"/> 4.15.6 Shared Parking Structure Lighting	
<input type="checkbox"/> 4.15.7 Shared Parking Structure Materials	
<input type="checkbox"/> 4.15.8 Shared Parking Structure Ground Floor Uses	
<input type="checkbox"/> 4.16 Rooftops	
<input type="checkbox"/> 4.16.1 Rooftop Façades	
<input type="checkbox"/> 4.17 Blank Walls	
<input type="checkbox"/> 4.17.1 Ground Floor Blank Walls	
<input type="checkbox"/> 4.17.2 Upper Floor Blank Walls	
<input type="checkbox"/> 4.18 Daylight	
<input type="checkbox"/> 4.18.1 Residential Daylight	
<input type="checkbox"/> 4.18.2 Commercial Daylight	

6.3 Checklist cont'd

STANDARD	NOTES
<input type="checkbox"/> 4.19 Façade Material	
<input type="checkbox"/> 4.19.1 Bird-Safe Design	
<input type="checkbox"/> 4.19.2 Material Quality	
<input type="checkbox"/> 4.19.3 Material Selection	
<input type="checkbox"/> 4.19.4 Ground Floor Materials	
<input type="checkbox"/> 4.19.5 Marine Environment Materials	
<input type="checkbox"/> 4.19.6 Prohibited Materials	
<input type="checkbox"/> 4.20 Class I - Bicycle Parking	
<input type="checkbox"/> 4.20.1 Bicycle Parking Capacity	
<input type="checkbox"/> 4.20.2 Bicycle Parking Location	
<input type="checkbox"/> 4.21 Vehicular Parking and Loading	
<input type="checkbox"/> 4.21.1 Vehicle Parking and Loading	
<input type="checkbox"/> 4.22 Skyway Connections	
<input type="checkbox"/> 4.22.1 Skyway Connections	
<input type="checkbox"/> 4.23 Green Room Datum	
<input type="checkbox"/> 4.23.1 Green Room Datum	
<input type="checkbox"/> 4.24 Adaptive Reuse	
<input type="checkbox"/> 4.24.1 Adaptive Reuse	
<input type="checkbox"/> 4.24.2 Adaptive Reuse Exemptions	
<input type="checkbox"/> 4.25 Key Sites Blocks 28 and 40	
<input type="checkbox"/> 4.25.1 Key Sites Blocks 28 & 40	

Private Open Space

STANDARD	NOTES
<input type="checkbox"/> 4.26 Private Open Space	
<input type="checkbox"/> 4.26.1 Private Open Space	
<input type="checkbox"/> 4.26.2 Private Common Open Space on Waterfront Blocks	
<input type="checkbox"/> 4.26.3 Private Setbacks	
<input type="checkbox"/> 4.26.4 Fences	
<input type="checkbox"/> 4.26.5 Defensible Space	
<input type="checkbox"/> 4.26.6 Orientation	
<input type="checkbox"/> 4.26.7 Planting Palette	
<input type="checkbox"/> 4.26.8 Irrigation	
<input type="checkbox"/> 4.27 Private Open Space - Mid-Block Breaks	
<input type="checkbox"/> 4.27.1 Public Access	
<input type="checkbox"/> 4.27.2 Throughway Dimensions	
<input type="checkbox"/> 4.27.3 Surfaces	
<input type="checkbox"/> 4.27.4 Street Trees	
<input type="checkbox"/> 4.27.5 Lighting	
<input type="checkbox"/> 4.27.6 Community Spaces	
<input type="checkbox"/> 4.27.7 Landscaping	
<input type="checkbox"/> 4.27.8 Minimizing Vehicular Speeds	

6.4 Checklist cont'd

Signage

STANDARD	NOTES
<input type="checkbox"/> 4.28 Building Signage	
<input type="checkbox"/> 4.29 All Signs	
<input type="checkbox"/> 4.29.1 Transparency	
<input type="checkbox"/> 4.29.2 Concealed Electrical Signage Elements	
<input type="checkbox"/> 4.29.3 Typefaces & Colors	
<input type="checkbox"/> 4.29.4 Sign Materials	
<input type="checkbox"/> 4.29.5 Graphic Style	
<input type="checkbox"/> 4.29.6 Integration	
<input type="checkbox"/> 4.29.7 New Technology Signs	
<input type="checkbox"/> 4.29.8 Sign Illumination	
<input type="checkbox"/> 4.29.9 Prohibited Signage	
<input type="checkbox"/> 4.30 Permanent Signs	
<input type="checkbox"/> 4.30.1 Commercial Wall Signage	
<input type="checkbox"/> 4.30.2 Storefront and Retail Wall Signage	
<input type="checkbox"/> 4.30.3 Residential Wall Signage	
<input type="checkbox"/> 4.30.4 Projecting Signs	
<input type="checkbox"/> 4.30.5 Window Signs	
<input type="checkbox"/> 4.30.6 Identifying, Freestanding, or Directional Signs	
<input type="checkbox"/> 4.30.7 Canopy/Awning Signage	
<input type="checkbox"/> 4.30.8 Street or Unit Address Signs Nameplates	
<input type="checkbox"/> 4.31 Temporary Signs	
<input type="checkbox"/> 4.31.1 Temporary Signs	
<input type="checkbox"/> 4.31.2 Portable Signs	

Lighting

STANDARD

NOTES

4.32 Building Lighting

4.32.1 Glare Reduction

4.32.2 Energy Consumption

4.32.3 Building Entrances

4.32.4 Dark Sky

4.32.5 Dark Sky Exemption

Private Infrastructure

4.33 Odor Control at the Recycled Water Facility

4.33.1 Odor Control at the Recycled Water Facility

6.5 Building Design Application Studies

The following building studies illustrate how the Guidelines and Standards apply in combination for M, L and XL buildings to support the vision for HPS2. These options illustrate an example of real world applications and the building envelopes do not necessarily maximize allowable block coverage. Selected controls and enhancement measures are indicated in bold. These designs are for illustrative purposes only.

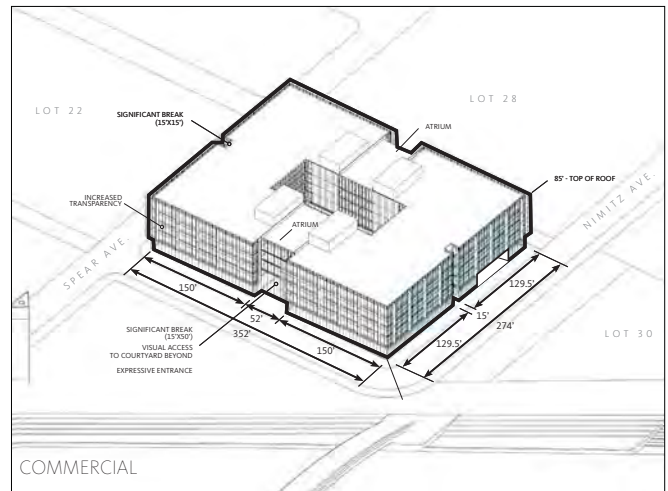
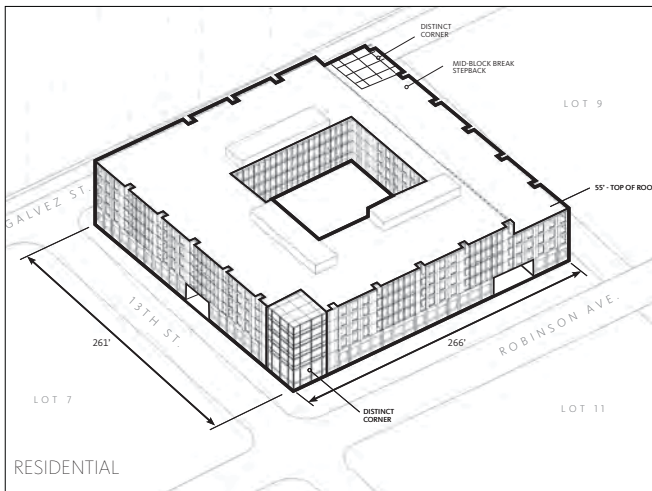

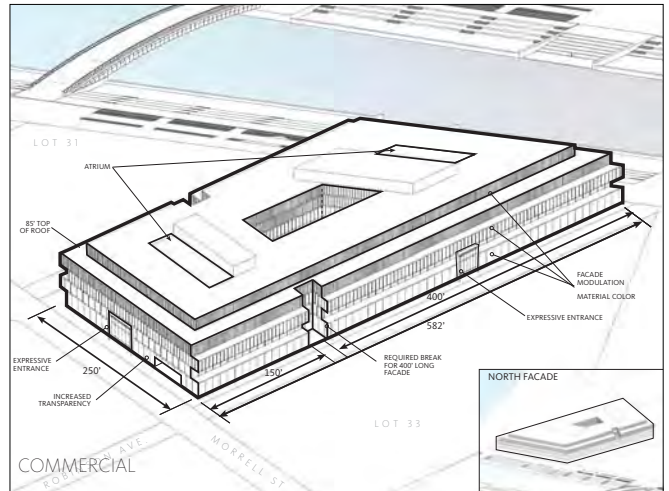
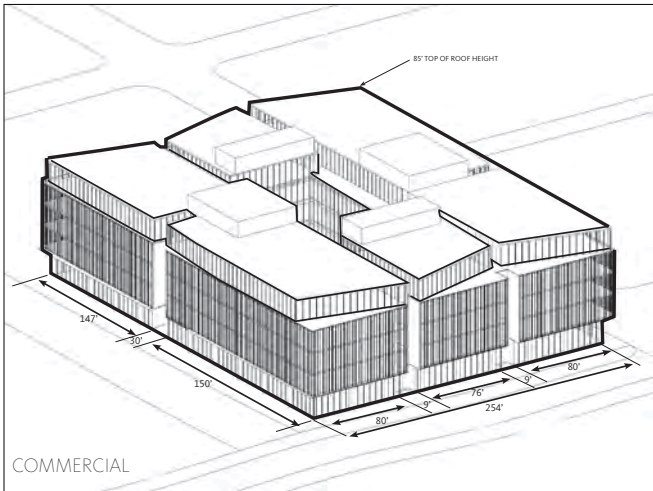

6.5.3 MEDIUM BUILDING (RESIDENTIAL - BLOCK 8)

BUILDING SIZE:

M

1 Bulk and Massing Control
and
1 Building Enhancement or
1 Public Realm Enhancement

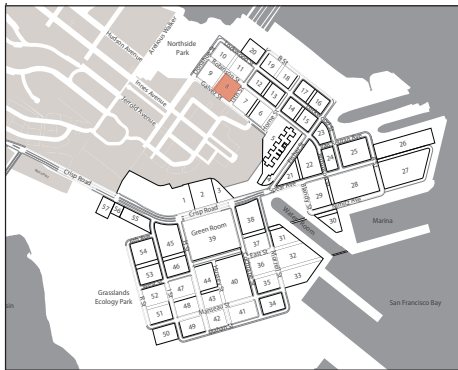

BUILDING DESIGN STANDARDS
 Zoning: Residential
 Lot Area: ~ 69,233 SF
 Developable Area:
 0'-40' : 100%
 41'-95' : 75%
 Gross Floor Area: 311,549 SF
 Setback: 5'-10' (Zone 3), 0'-10' (Zone 4-MBB),
 15' (Zone 6)
 Plan Length: 250'
 Number of Stories: 5
 Building Height: 45' Min / 55' Max)
 Street Wall: 50%/20' (Typical)

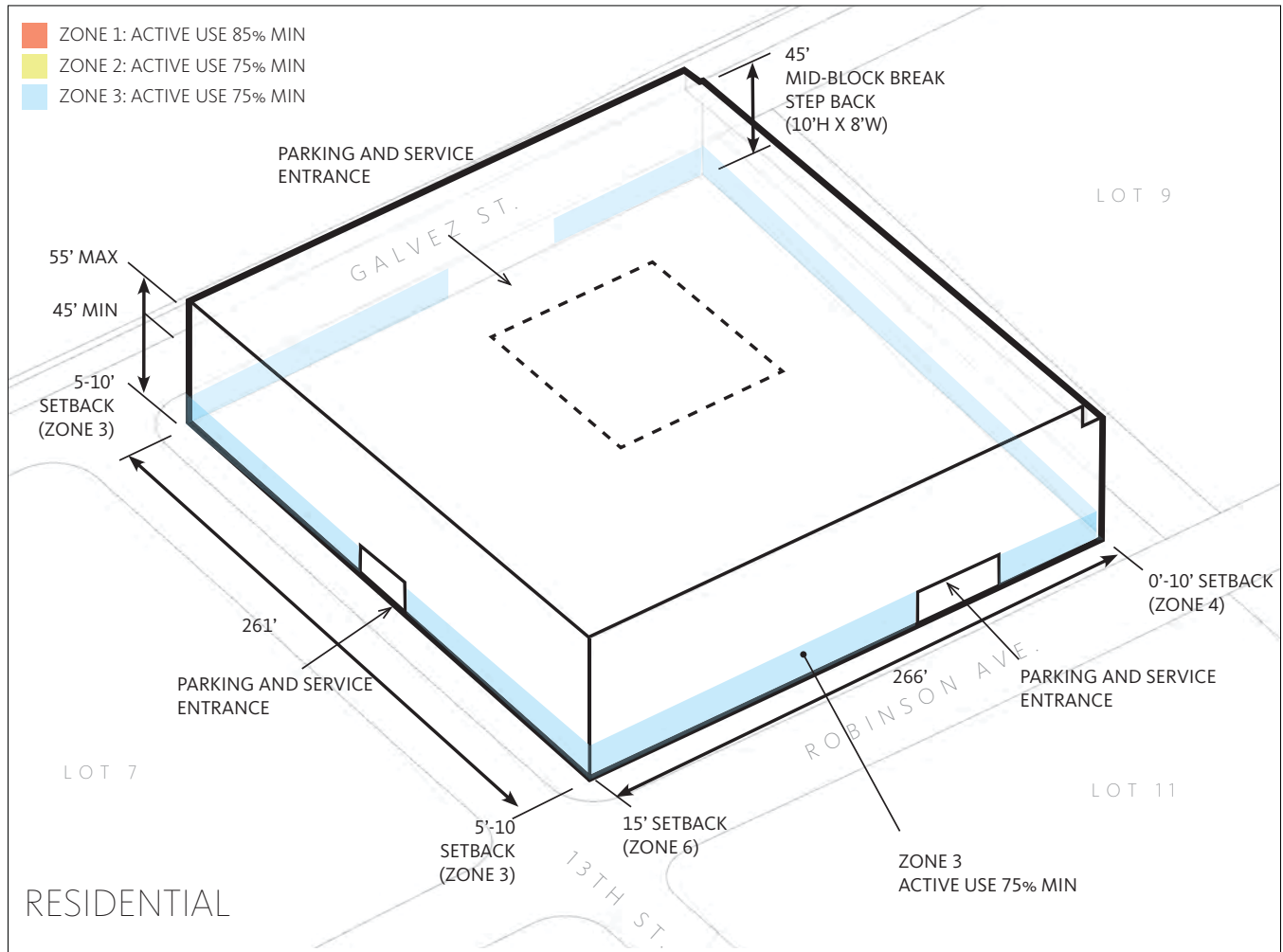

STEP 1

FACADE COMPOSITION (FC), PICK TWO

- FC1. Façade Modulation Strategies**
- FC2. Façade Articulation Strategies
- FC3. Façade Fenestration Strategies
- FC4. Material/Color Strategies**

STEP 2

BULK AND MASSING (BM)

- BM1. Significant Building Breaks**
- BM2. Upper Floor Stepbacks
- BM3. Façade Variation (pick two)
 - Façade Modulation
 - Façade Articulation
 - Fenestration/ Transparency
 - Material Color

STEP 3

BUILDING ENHANCEMENT (BE)

- BE1. Apply One [1] Additional Bulk/Massing Control
- BE2A. Orient Private Courtyards and/or Atria Onto a Public ROW or MBB (Per Street Fronting Elevation)
- BE2B. Orient Private Courtyards and/or Atria Onto a Public ROW or MBB (Multiple Street Fronting Elevations)
- BE3. Provide Visual and Physical Access to Interior Courtyard and/or Atrium
- BE4. Permanently Open Public Access to Open Space
- BE5. Reduction in Floor Plate Area of Upper Floors
- BE6. Expressive Entrances
- BE7. Increased Transparency
- BE8. Distinct Corner Architectural Feature**
- BE9. Roof Expression
- BE10. Additional Active Entries
- BE11. Additional Ground Floor Activation
- PUBLIC REALM ENHANCEMENT (PE)**
- PE1. Public Access Through the Building
- PE2. Public Access though Open Space Connection

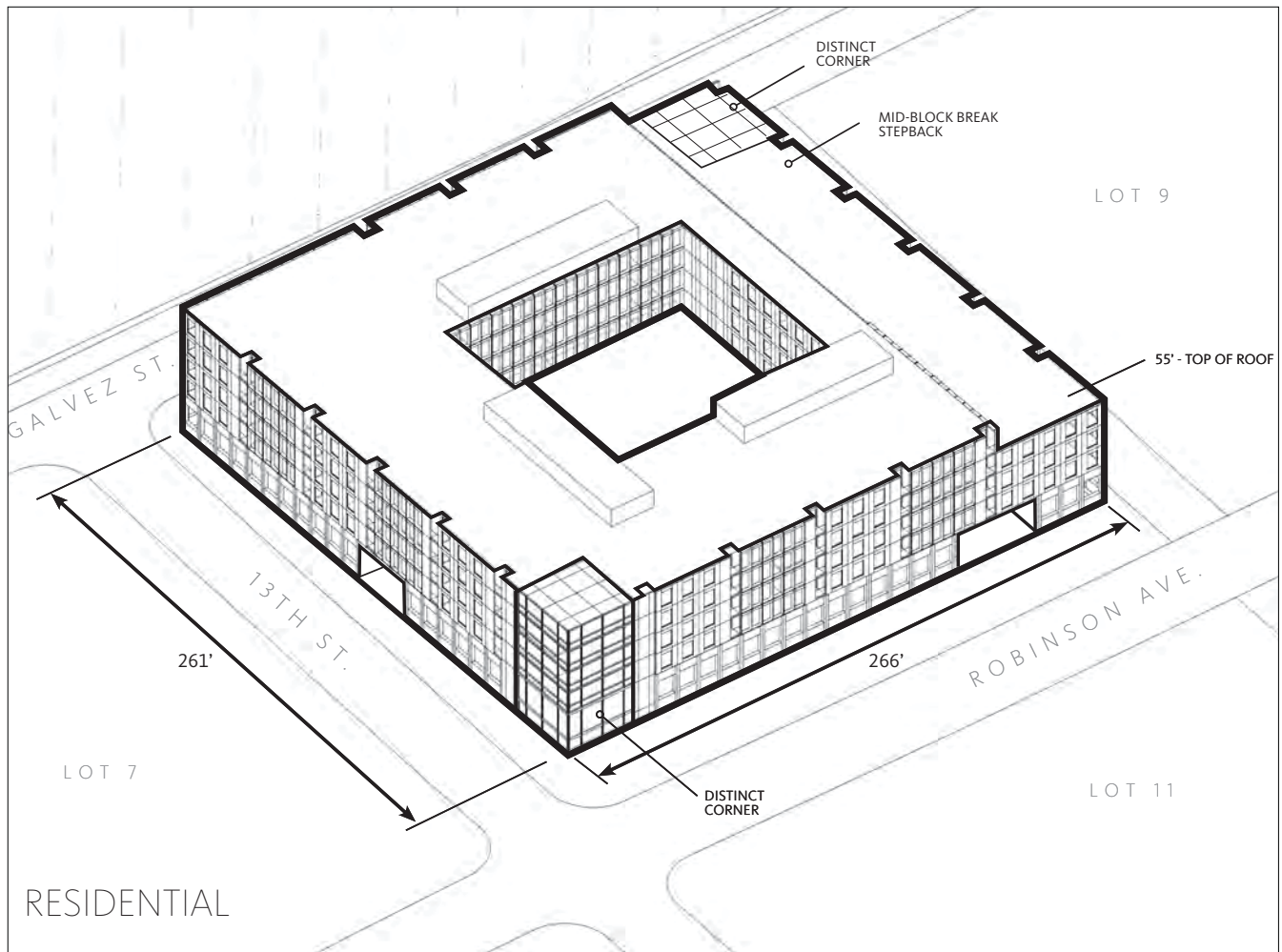

6.5.4 LARGE BUILDING (COMMERCIAL - BLOCK 29)

BUILDING SIZE:



1 Bulk and Massing Control
and
3 Building Enhancements
or
1 Building Enhancement and
1 Public Realm Enhancement

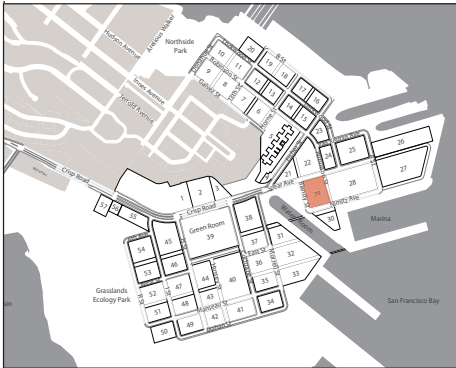

BUILDING DESIGN STANDARDS
 Zoning: Commercial
 Lot Area: 96,478 SF
 Developable Area:
 0-40' : 100%
 41'-95' : 90%
 96'-120' : 80%
 Gross Floor Area: 410,032 SF
 Setback: 0' (Zone 1)
 Plan Length: 350'
 Number of Stories: 5
 Building Height: 40' Min / 85' Max)
 Street Wall: 85%/60', 50%/20'

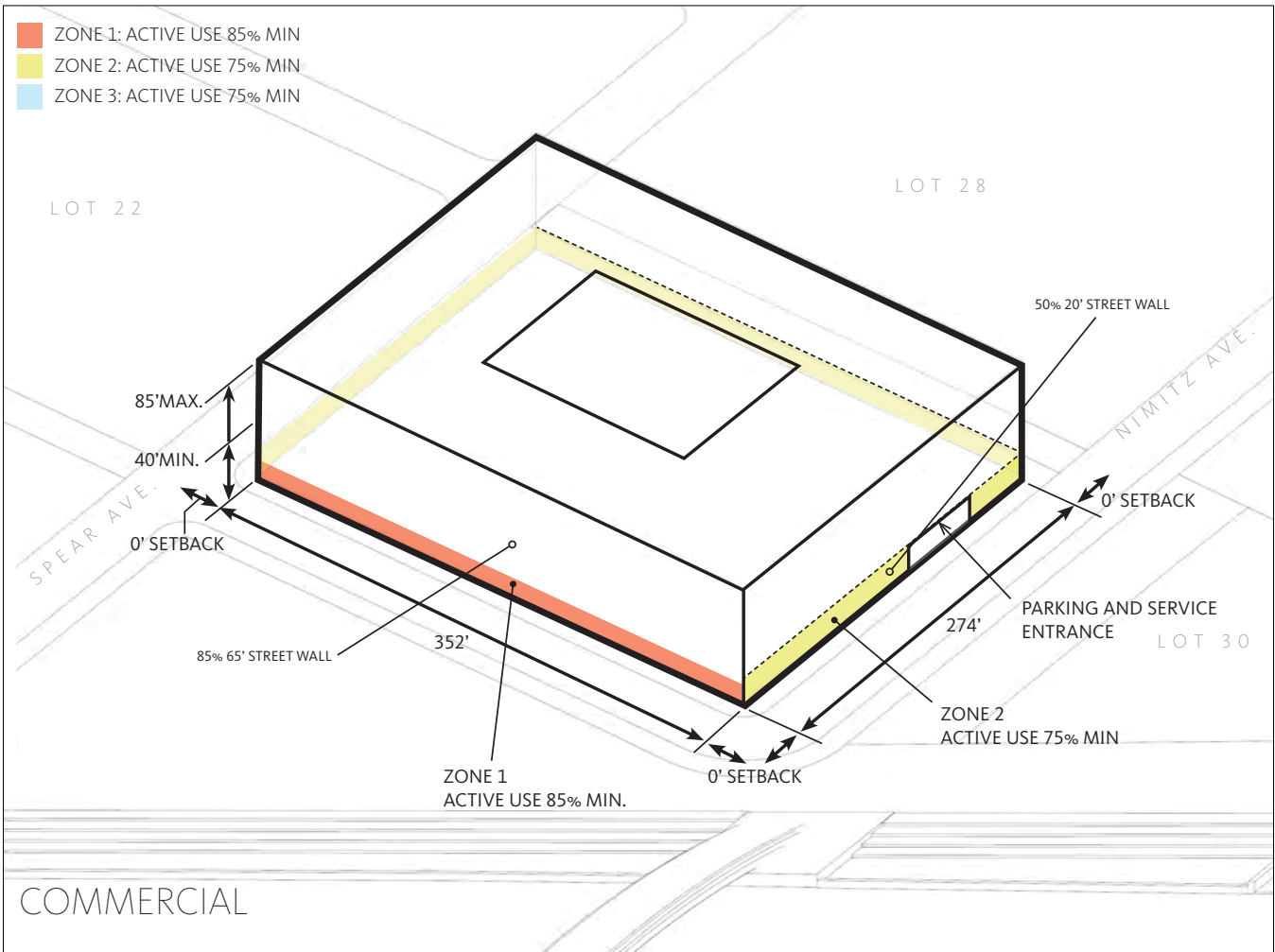

STEP 1

FACADE COMPOSITION (FC), PICK TWO

- FC1. Façade Modulation Strategies**
- FC2. Façade Articulation Strategies
- FC3. Façade Fenestration Strategies**
- FC4. Material/Color Strategies

STEP 2

BULK AND MASSING (BM)

- BM1. Significant Building Breaks**
- BM2. Upper Floor Stepbacks
- BM3. Façade Variation (pick two)
 - Façade Modulation
 - Façade Articulation
 - Fenestration/ Transparency
 - Material Color

STEP 3

BUILDING ENHANCEMENT (BE)

- BE1. Apply One [1] Additional Bulk/Massing Control
- BE2A. Orient Private Courtyards and/or Atria Onto a Public ROW or MBB (Per Street Fronting Elevation)
- BE2B. Orient Private Courtyards and/or Atria Onto a Public ROW or MBB (Multiple Street Fronting Elevations)
- BE3. Provide Visual and Physical Access to Interior Courtyard and/or Atrium**
- BE4. Permanently Open Public Access to Open Space
- BE5. Reduction in Floor Plate Area of Upper Floors
- BE6. Expressive Entrances**
- BE7. Increased Transparency**
- BE8. Distinct Corner Architectural Feature
- BE9. Roof Expression
- BE10. Additional Active Entries
- BE11. Additional Ground Floor Activation
- PUBLIC REALM ENHANCEMENT (PE)**
- PE1. Public Access Through the Building
- PE2. Public Access though Open Space Connection

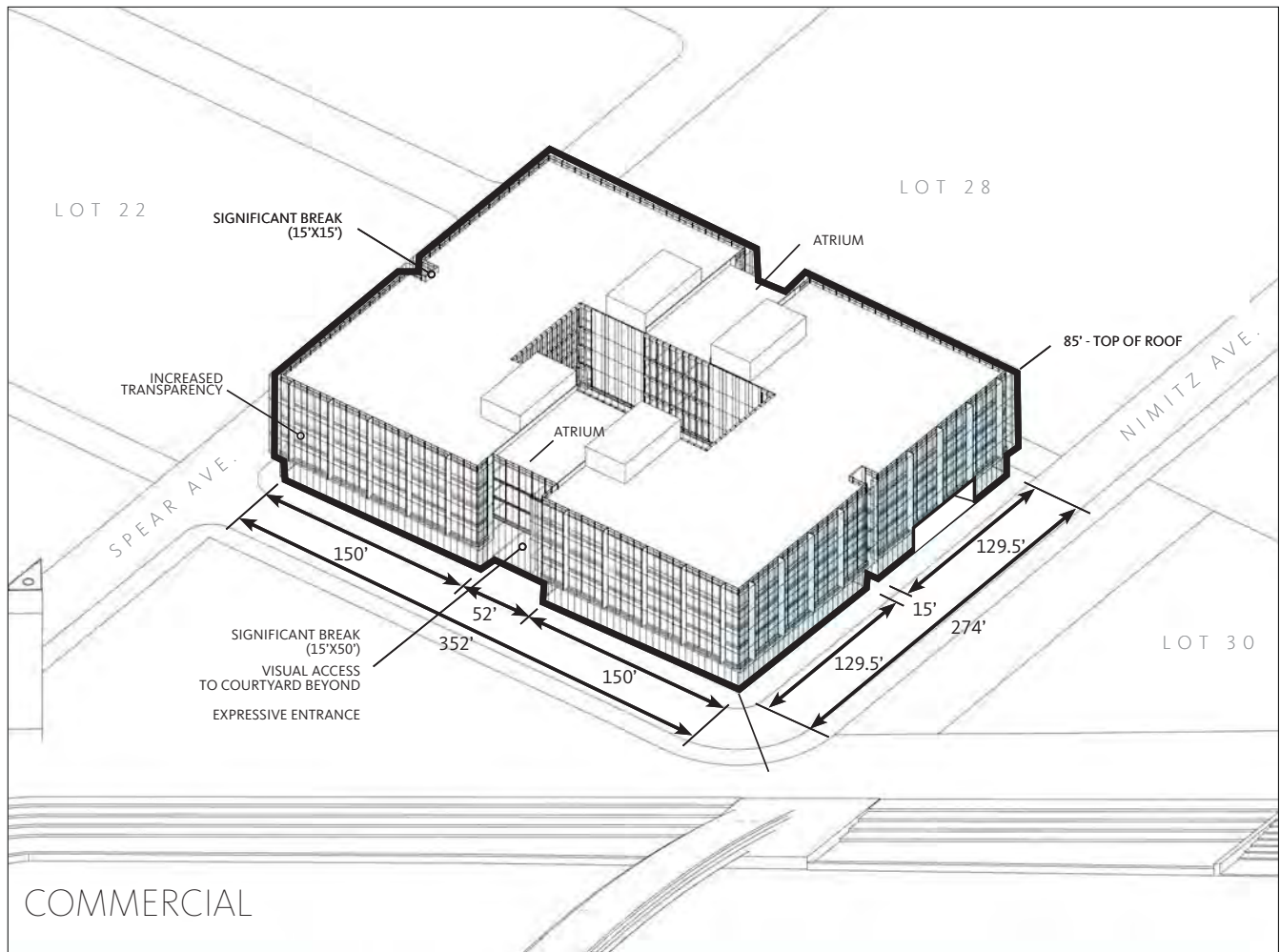

6.5.5 LARGE BUILDING (COMMERCIAL - BLOCK 44)

BUILDING SIZE:



1 Bulk and Massing Control
and
3 Building Enhancements
or
1 Building Enhancement and
1 Public Realm Enhancement

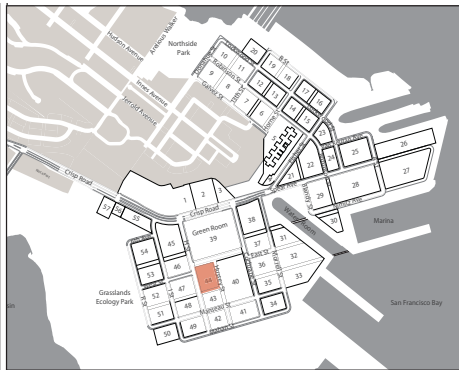

BUILDING DESIGN STANDARDS

Zoning: Residential
 Lot Area: 83,017 SF
 Developable Area:
 0-40' :100%
 41'-95' : 90%
 96'-120' : 80%
 Gross Floor Area: 415,082
 Setback: 0' (Zone 1), 0'-5' (Zone 2)
 Plan Length: 363'
 Number of Stories: 5
 Building Height: 40' Min / 85' Max
 Street Wall: 85%/60%

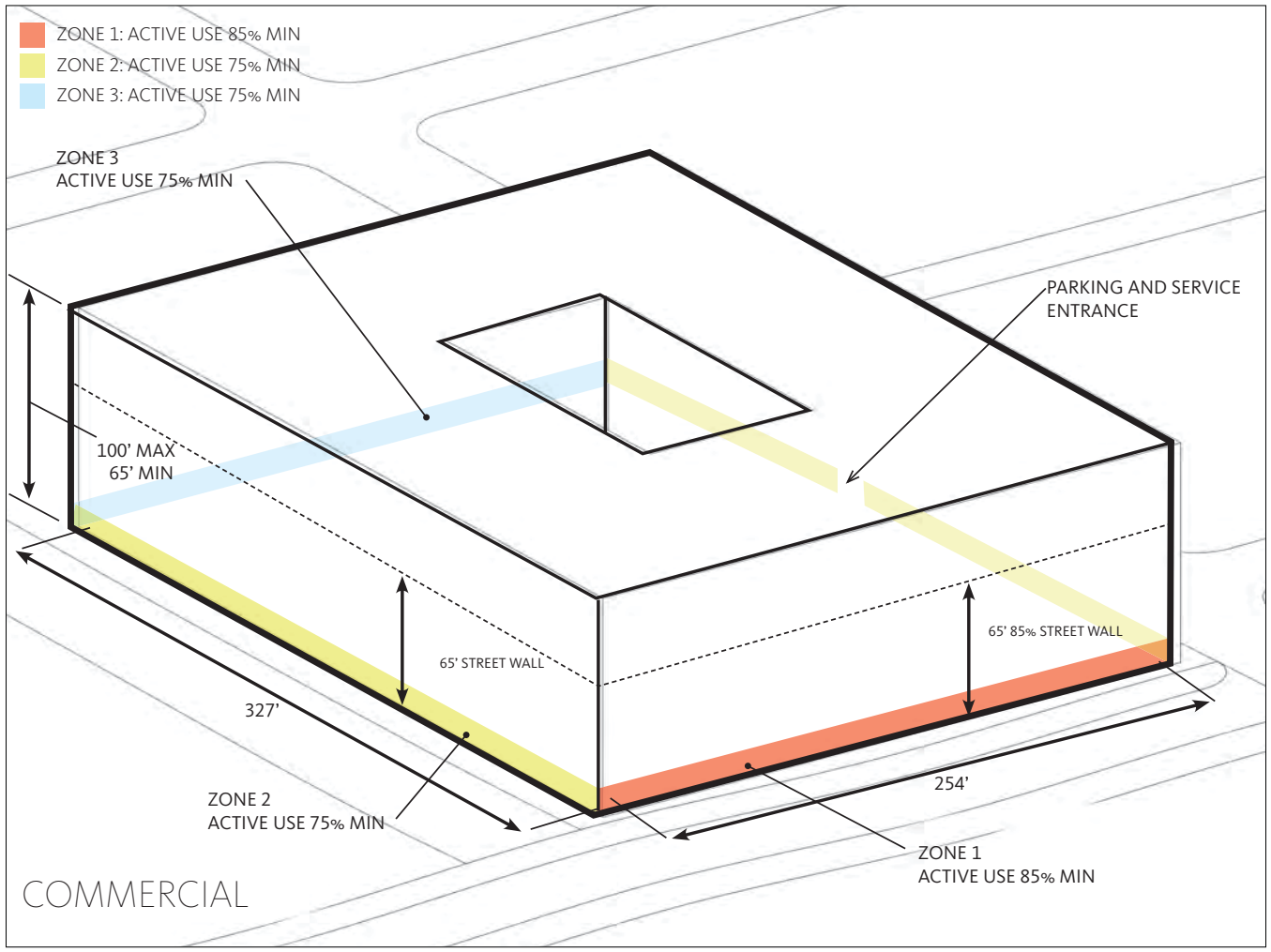

STEP 1

FACADE COMPOSITION (FC), PICK TWO

- FC1. Façade Modulation Strategies**
- FC2. Façade Articulation Strategies
- FC3. Fenestration Strategies**
- FC4. Material / Color Strategies

STEP 2

BULK AND MASSING (BM)

- BM1. Significant Building Breaks**
- BM2. Upper Floor Stepbacks
- BM3. Façade Variation (pick two)
 - Façade Modulation
 - Façade Articulation
 - Fenestration/ Transparency
 - Material Color

STEP 3

BUILDING ENHANCEMENT (BE)

- BE1. Apply One [1] Additional Bulk/Massing Control
- BE2A. Orient Private Courtyards and/or Atria Onto a Public ROW or MBB (Per Street Fronting Elevation)
- BE2B. Orient Private Courtyards and/or Atria Onto a Public ROW or MBB (Multiple Street Fronting Elevations)
- BE3. Provide Visual Access to Interior Courtyard and/or Atrium
- BE4. Permanently Open Public Access to Open Space
- BE5. Reduction in Floor Plate Area of Upper Floors**
- BE6. Expressive Entrances
- BE7. Increased Transparency**
- BE8. Distinct Corner Architectural Feature
- BE9. Roof Expression**
- BE10. Additional Active Entries
- BE11. Additional Ground Floor Activation
- PUBLIC REALM ENHANCEMENT (PE)**
- PE1. Public Access Through the Building
- PE2. Public Access though Open Space Connection

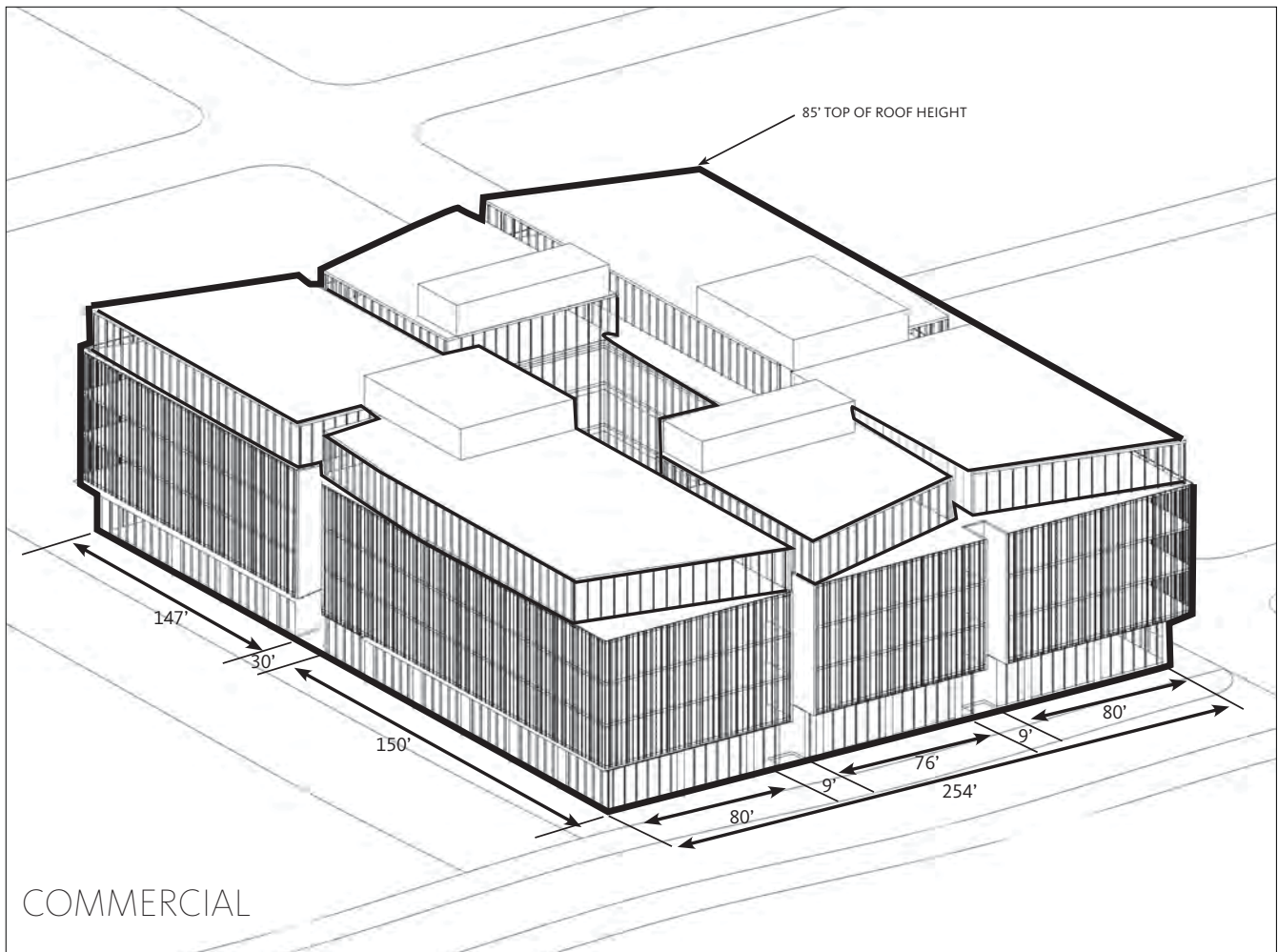

6.5.6 EXTRA-LARGE BUILDING (COMMERCIAL - BLOCK 32)

BUILDING SIZE: **XL**

1 Bulk and Massing Control
and
4 Building Enhancements
or
2 Building Enhancements and
1 Public Realm Enhancement

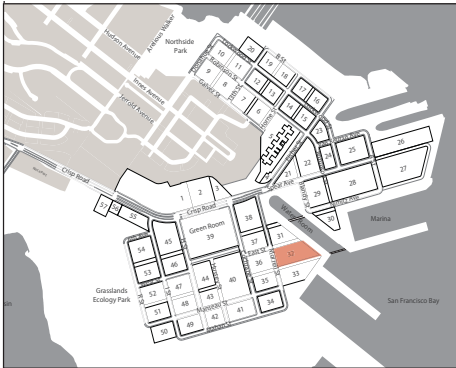

BUILDING DESIGN STANDARDS

Zoning: Commercial
 Lot Area: 121,012 SF
 Developable Area:
 0-40' : 100%
 41'-95' : 90%
 96'-120' : 80%
 Gross Floor Area: 514,301 SF
 Setback: 0' (Zone 1)
 Plan Length: 395'
 Number of Stories: 5
 Building Height: 40' Min / 85' Max)
 Street Wall: 85%/60', 50%/20'

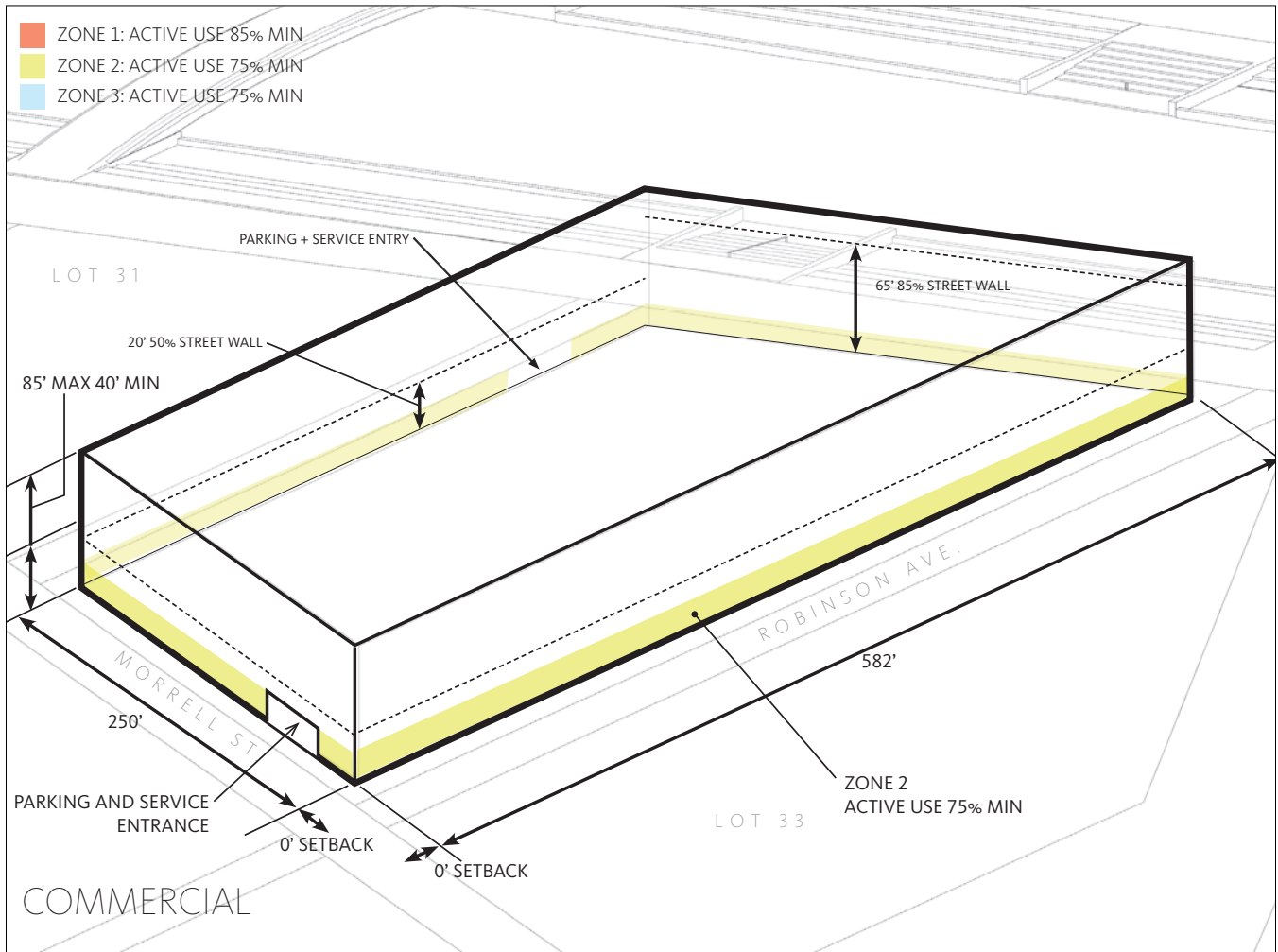

STEP 1

FACADE COMPOSITION (FC), PICK TWO

- FC1. Façade Modulation Strategies**
- FC2. Façade Articulation Strategies
- FC3. Façade Fenestration Strategies**
- FC4. Material/Color Strategies

STEP 2

BULK AND MASSING (BM)

- BM1. Significant Building Breaks
- BM2. Upper Floor Stepbacks**
- BM3. Façade Variation (pick two)**
 - Façade Modulation
 - **Facade Articulation**
 - Fenestration/ Transparency
 - **Material Color**

STEP 3

BUILDING ENHANCEMENT (BE)

- BE1. Apply One [1] Additional Bulk/Massing Control**
- BE2A. Orient Private Courtyards and/or Atria Onto a Public ROW or MBB (Per Street Fronting Elevation)
- BE2B. Orient Private Courtyards and/or Atria Onto a Public ROW or MBB (Multiple Street Fronting Elevations)
- BE3. Provide Visual and Physical Access to Interior Courtyard and/or Atrium**
- BE4. Permanently Open Public Access to Open Space
- BE5. Reduction in Floor Plate Area of Upper Floors
- BE6. Expressive Entrances**
- BE7. Increased Transparency**
- BE8. Distinct Corner Architectural Feature
- BE9. Roof Expression
- BE10. Additional Active Entries
- BE11. Additional Ground Floor Activation
- PUBLIC REALM ENHANCEMENT (PE)**
- PE1. Public Access Through Building
- PE2. Public Access through Open Space Connection

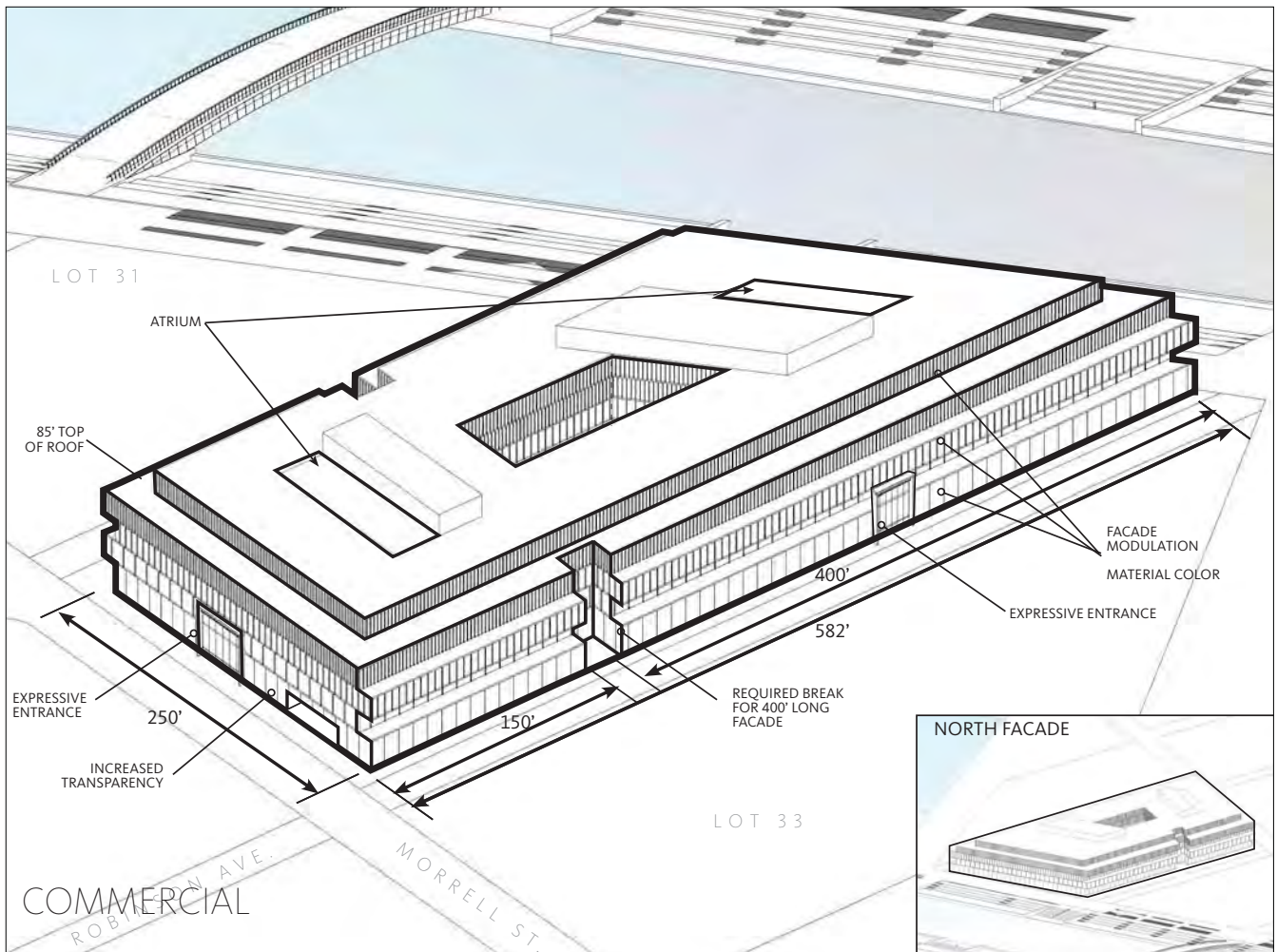

6.6 Sitewide Diagrams

6.6.7 DISTRICTS MAP



Figure 6.3a: DISTRICTS AND DEVELOPMENT BLOCKS

6.6.8 ROUGH FINISH GRADES

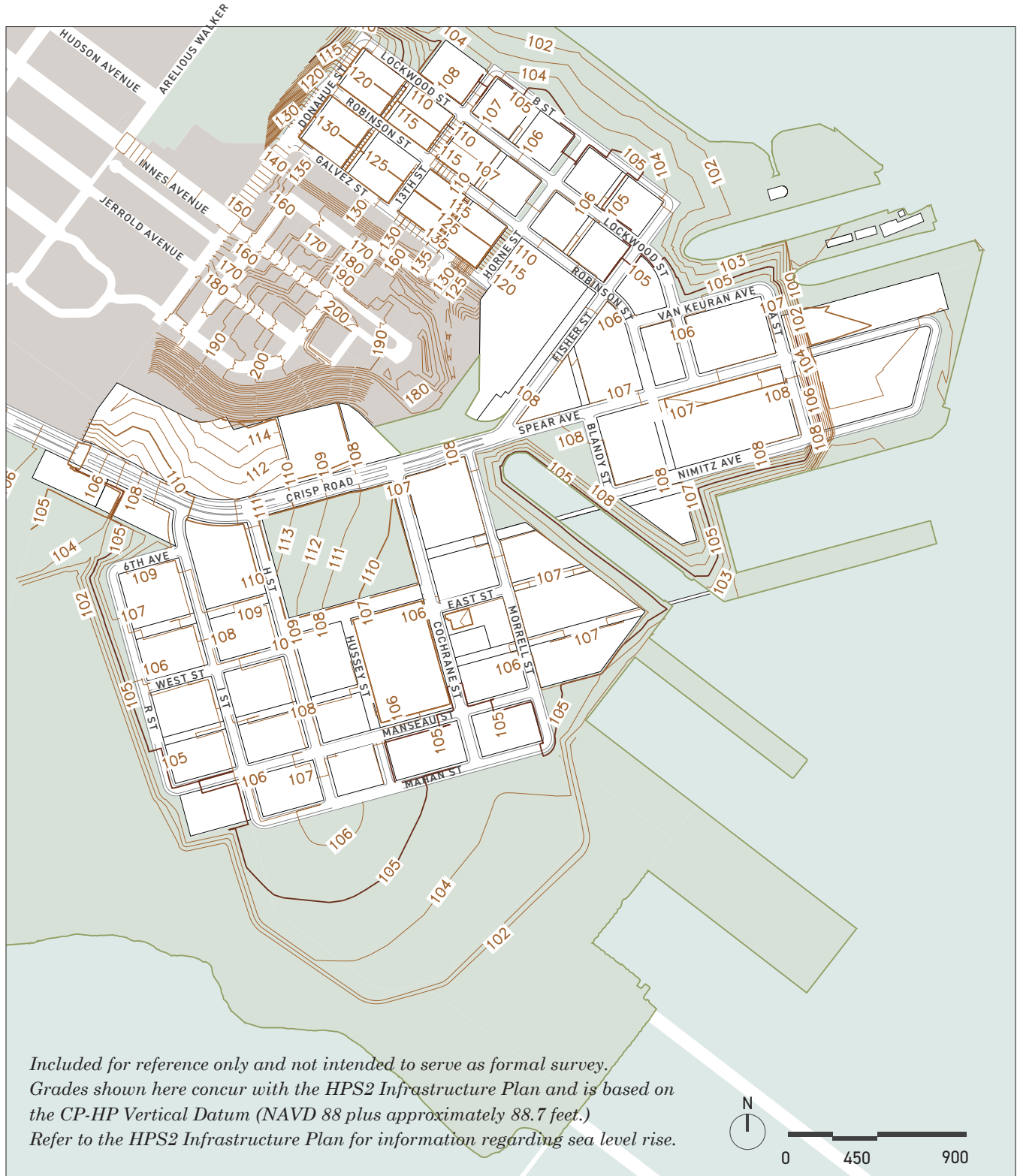

Figure 6.3b: TOPOGRAPHY

6.6.9 PHASING

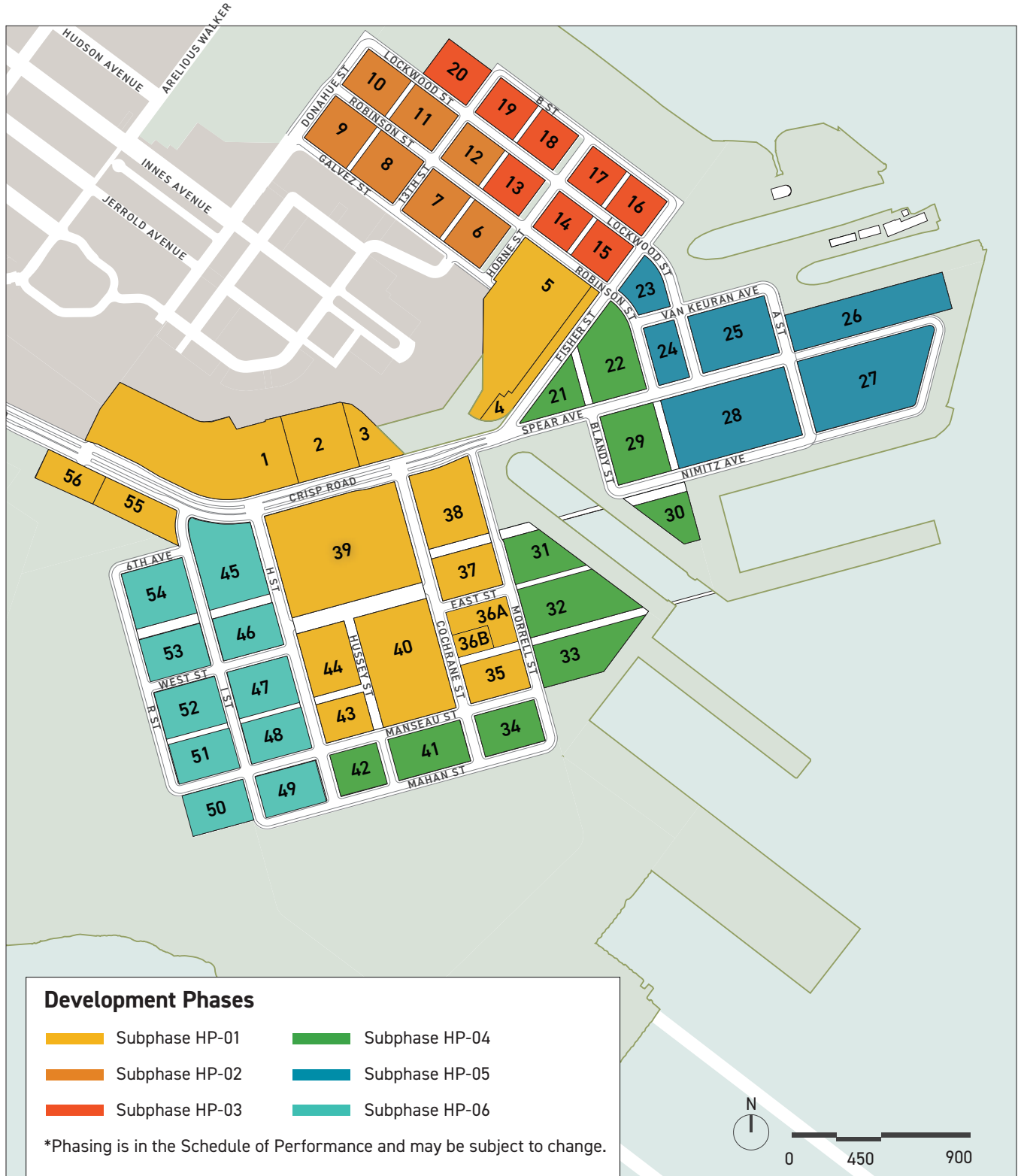

Figure 6.3c: DEVELOPMENT PHASES

6.7 Term Definitions

Terms used in the D4D shall have the meaning defined in Part XI of the HPS Redevelopment Plan, or as otherwise outlined below. In the event of inconsistency between a term definition in the HPS Redevelopment Plan and the D4D, the term definition in the HPS Redevelopment Plan shall prevail:

Active Entrance	A building entrance into an Active Use. Entrance may be public or private. Single uses may have multiple Active Entries.
Active Frontage	Building façade length lined with Active Uses.
Active Uses	Ground floor land uses that create an interesting and inviting pedestrian environment that enhances neighborhood safety and security by encouraging "eyes on the street," visibility and vibrancy.
Active Use Transparency	The surface area of Transparent Glazing as a proportion of the surface area of the Active Frontage.
Adaptive Reuse	Reuse or re-creation of an existing structure, in part or in whole, in a manner that maintains the essence and character-defining building elements of the existing structure.
Agency	The Office of Community Investment and Infrastructure, or Successor Agency to the San Francisco Redevelopment Agency.
Apparent Face	The unbroken plane of a building with a single façade composition.
Atrium	A multi-leveled enclosed building area that is glazed on one [1] or more sides and includes roof glazing and/or skylights.
Awning	A light, roof-like structure, supported entirely by the exterior wall of a building, consisting of a moveable frame covered with approved materials, extending over doors and windows, with the purpose of providing protection from sun and rain and embellishment of the façade.
Blank Wall	A building façade area greater than four [4] linear ft. in length, parallel to the property line where there is not an entrance, window, or any building articulation, including solid doors and mechanical area wall(s).
Block	An area bounded by a public right-of-way, open space, or Mid-Block Break.
Block Sizes	Block Sizes and legal parcels are defined in the Final Map. Approximate parcel dimensions are provided in <i>Figure 4.1b</i> and are subject to change. Block sizes may be legal parcels or may be part of a legal parcel.
Building Enhancement	An architectural design feature that improves the character of the building and adds interest to the building overall.
Building Entry	Building doors not including service or loading access, parking entries, or locked fire exits.

Building Envelope	The exterior dimensions dictating the maximum dimensions of width, depth, height, and bulk, within which a building may exist on a given site.
Building Face	A plane of the exterior wall of the building along a public right-of-way, open space, or other publicly accessible space. The term is often used in context with its relationship to an adjacent street or public area. In instances where a minimum Street Wall requirement presides, the Building Face aligns with the build-to line.
Building Height	<p>Building Height is measured from the highest corner at finished sidewalk grade to the average point on the finished roof in the case of a flat roof, and the average height of the rise in the case of a pitched or stepped roof, or similarly sculpted roof form.</p> <p>For parcels adjacent to streets with a slope greater than 5%, Building Height is determined by measuring at the mid-point of the building at the sidewalk grade adjacent to each street-fronting Building Face. The maximum height envelope may extend from one frontage up to a depth of half the distance to the opposite side of the block. Multiple frontages may be used to determine maximum Building Height envelope.</p>
Building Projection	A portion of the building that extends beyond the primary Building Face, either into a Setback or beyond the property line.
Bulk and Massing	Bulk and Massing regulations are the combination of controls (lot size, lot coverage, open space, yards, heights, and setbacks) that determine the maximum Building Envelope.
Business/Retail Signage	A Sign which directs attention to the primary business, commodity, service, industry or other activity which is sold, offered, or conducted on the premises upon which the Sign is located or to which it is affixed.
Canopy	A light, roof-like structure, supported by the exterior of a building, consisting of a fixed frame covered with approved cloth, plastic, or metal, with the purpose of providing protection from sun and rain, and embellishment of the façade.
Calculating Sign Area	Sign area is defined as the area of a sign that is used for display purposes. Sign area shall be calculated by measuring the size of a rectangle large enough to contain the entire sign's display, graphics, and text that form an integral part of the display or are used to differentiate such sign from the background against which it is placed. The calculation of Sign Area excludes the necessary supports or uprights on which such sign is placed.
Canopy or Awning Signs	Lettering or graphics applied to projecting architectural awnings or canopies at the first floor.
Character-enhancing Structure	Buildings or structures that may be adaptively reused to enhance neighborhood character and sense of place. Character-enhancing Buildings are 281, 351, 411, and 813.
Class I Bicycle Parking	Spaces in secure, weather-protected facilities intended for use as long-term, overnight, and workday bicycle storage by dwelling unit residents, non-residential occupants, and employees.

Clearly Defined Building Entry	A clearly identifiable building entry is expressed by such elements as taller volumes, recessed doorways, canopies, lighting, public art, special materials, and/or paving.
Convertible Parking	A Shared Parking Structure designed to be converted into another use and or designed to be mechanized and deconstructable.
Coverage	The percentage of Floor Plate in relation to the Developable Area that includes the total horizontal area when viewed in plan. Coverage is regulated at various height thresholds.
Datum	An articulation strategy on the building façade that, by its continuity and regularity, serves to gather, measure, and organize the pattern of forms and spaces.
Daylight	The controlled admission of natural light, direct sunlight, and diffused skylight into a building to reduce electric lighting and save energy.
Developable Area	All land inside the legal property line, excluding Setbacks.
District	A grouping of development blocks that share a number of similar characteristics.
EVA	Emergency Vehicular Access.
Extra Large Building (XL)	Buildings with a maximum floor plate area greater than [100,000] sq. ft.
Façade	Any vertical exterior face or wall of a building that is adjacent to or fronts a street, public or semi-private right-of-way, park, or plaza.
Façade Articulation	Expressions of material properties, craft, treatment, pattern, and/or assembly that create visible shadows and/or texture across the building façade. Façade Articulation strategies are intended to create visual interest, texture, and shadows through the tectonics, materiality, and craft of the façade.
Façade Composition	The design of large scale building form and smaller scale façade tectonics, including material selection and detailing.
Façade Modulation	
Fenestration	The design, construction, or presence of openings in a building. Fenestration includes windows, doors, louvers, vents, wall panels, skylights, storefronts, curtain walls, and slope glazed systems.
Floor Aspect Ratio	The ratio that controls the proportions of the Floor Plate. Floor Aspect Ratio compares the shorter plan dimension of the Floor Plate to the longer plan dimension. A square Floor Plate would have an aspect ratio of 1:1.
Floor Plate	The Gross Floor Area for an individual floor level of a building.
Freestanding or Directional Signs	Signs detached from the building, and in no part supported by the building, providing identification, information, or direction to a building or group of buildings.
Gateway	A primary vehicular or pedestrian point of entry into the development project, typically at a key intersection between two or more public streets.

Gross Floor Area

The sum of the gross areas of the several floors of a building or buildings, measured from the exterior faces of exterior walls or from the centerlines of walls separating two buildings. Where columns are outside and separated from an exterior wall (curtain wall) that encloses the building space or are otherwise so arranged that the curtain wall is clearly separate from the structural members, the exterior face of the curtain wall shall be the line of measurement, and the area of the columns themselves at each floor shall also be counted.

Shall include, but not be limited to, the following:

- Basement and cellar space, including tenants' storage areas and all other spaces except that used only for storage or services necessary to the operation or maintenance of the building itself
- Elevator shafts, stairwells, exit enclosures, and smoke-proof enclosures at each floor
- Floor space in penthouses except as specifically excluded in this definition
- Attic space capable of being made into habitable space
- Floor space in balconies or mezzanines in the interior of the building
- Floor space in open or roofed porches, arcades, or exterior balconies, if such porch, arcade, or balcony is located above the ground floor or first floor of occupancy above basement or garage and is used as the primary access to the interior space it serves
- Any floor area dedicated to accessory or non-accessory parking

Shall not include the following:

- Mechanical equipment, appurtenances, and areas necessary to the operation or maintenance of the building itself if located at an intermediate story of the building and forming a complete floor level
- Outside stairs to the first floor of occupancy at the face of the building which the stairs serve, or fire escapes
- Required off-street loading and required car-share parking
- Bicycle parking
- Balconies, porches, roof decks, terraces, courts, and similar features, except those used for primary access provided that:
 - If more than 70 percent of the perimeter of such an area is enclosed, either by building walls (exclusive of a railing or parapet not more than three feet eight inches high) or by such walls and interior lot lines, and the clear space is less than 15 feet in either dimension, the area shall not be excluded from Gross Floor Area unless it is fully open to the sky
 - If more than 70 percent of the perimeter of such an area is enclosed, either by building walls (exclusive of a railing or parapet not more than three feet eight inches high), or by such walls and interior lot lines, and the clear space is 15 feet or more in both dimensions: (i) The area shall be excluded from Gross Floor Area if
 - If, however, 70 percent or less of the perimeter of such an area is enclosed by building walls (exclusive of a railing or parapet not more than three feet eight inches high) or by such walls and interior lot lines, and the open side or sides face on a yard, street or court whose dimensions satisfy the requirements.

Ground Floor

The lowest story of a building that is at or nearest to sidewalk grade other than a basement or cellar as defined in the Building Code.

Habitable Projections	A portion of the building enclosed by walls and a roof which extends beyond the property or minimum Setback line. Examples include a bay window, a corner element, or a regularly occurring façade modulation that extends through some or all floors of a building.
High Albedo	Materials that reflect sunlight and limit the amount of heat gained through those materials. High Albedo Roofing materials are chosen to reduce unwanted heating of roof surfaces.
Horizontal Shift	A horizontal change in the building façade. A horizontal change shall include at least one floor of the building façade.
Identifying Signs	Primary parcel identification signs, which may be projecting, wall-mounted, or freestanding.
Implied Façade	An Implied Façade is a Building Face that completes the apparent massing through vertical and horizontal architectural elements, such as the roof line, columns, angular shifts, or other elements, that extend to and maintain the Street Wall.
Large Building (L)	Buildings with a maximum floor plate area between [70,000] and [100,000] sq. ft.
Lot Coverage	The percentage of the lot area that is covered by building area, which includes the total horizontal area when viewed in plan.
Maker Space	Uses for contemporary forms of small-scale manufacturing, repair, and post-manufacturing activities. Maker Space should typically include a retail component, and may include several other uses within a single space, including but not limited to light industrial, office, research and development, and Neighborhood Retail Sales and Services, among many others.
Material/Color	The application of materials, color, shades, and texture for a building when used as a quality- and character-defining feature of the façade.
Maximum Plan Length	The maximum linear dimension of a building measured in plan along a building elevation parallel to the immediately adjacent public right-of-way, MBB, or Public Open Space.
Medium Building (M)	Buildings that have a maximum plan dimension greater than [150] ft. in length along any facade and have a maximum floor plate area less than [70,000] sq. ft.
Mid-Block Breaks or MBBs	A pedestrian, bicycle, and/or vehicle lane way on private property.
Mid Block Break Width	The mandatory Street Wall to Street Wall width for a MBB and associated Setback Zones.
Non-habitable Projections	A portion of the building not enclosed by walls and a roof which extends beyond the property or minimum setback line. Examples include usable balconies or outdoor decks, structural projections, screening, awnings, and fins. Or similar architectural elements.
Parking Entrance	Entries allowing vehicular access to parking areas, including Shared Parking Structures, podium parking, and/or below grade parking.
Portable Signs	Signs which are freestanding, movable, and not permanently anchored or attached to the ground.

Primary Building Entries	The main entries to a building.
Primary Façade Plane	The plane that incorporates the primary façade of a Street Fronting Elevation.
Projecting or Blade Signs	Signs attached to a building, projecting perpendicular to the mounting surface.
Projection	The horizontal distance by which the furthestmost point used in measuring the area of a sign extends beyond a Street Property Line or a Building Setback Line.
Public Realm	An expansion of the pedestrian network that provides public access through private developments.
Public Realm Enhancement	An expansion of the pedestrian network that provides a continuation of public access through private developments.
Regularly Occupied Floor Area	An area where one [1] or more individuals normally spend time (more than one [1] hour per person per day on average) seated or standing as they work, study, or perform other focused activities inside a building.
Residential Private Individual Open Space	Intended for the use of individual residents within a unit and includes terraces, patios, balconies, rooftop spaces and other similar areas.
Residential Private Common Open Space	Intended to be shared by all residents/users within a building or building cluster and includes rooftop spaces, internal courtyards, gardens, pools, play areas, and other similar areas.
Rounding	For purposes of calculating a number, any fraction equal to or greater than one half (1/2) shall be rounded up to the nearest whole number and any fraction less than one half (1/2) shall be rounded down to the nearest whole number.
Roof-Mounted Equipment	Any equipment installed on the roof of a structure, such as air conditioners, compressors, condensers, conduits, pipes, vents, ducts, and sustainable systems such as solar ready equipment.
Screening	A physical visual barrier that obstructs or obscures the view of an object or objects. Screening may include shading devices, trellises, canopies, fences, landscaping, and architectural treatments.
Setback	The required horizontal distance between a building face and a property line.
Service Entrance	Entries allowing vehicular access for trucks and/or deliveries, loading, and/or access to trash rooms.
Shared Parking Structure	A stand-alone structure providing Accessory Parking to off-site, lawful, non-Accessory uses and not attached to or included within a building containing a lawful non-Accessory use.
Sign	A display used to identify a place, business, or a product.
Significant Break	A vertical change in the building façade. A vertical plane break shall be at least as wide as 10% of the longest adjoining façade length.
Skyways	Upper level connections between buildings are primarily for pedestrians, although they could also be used for small service vehicles. Skyways may be enclosed or open air.

Small Building (S)	Buildings that have maximum plan dimensions that are less than [150] ft. in length along each building face and have a maximum floor plate area less than [22,500] sq. ft.
Stepback	The distance that upper levels of a building may be inset from the primary Building Face.
Stoop	An outdoor entryway into residential units raised above the sidewalk level.
Storefront	The façade of a ground-floor Active Use space between the street grade and the ceiling of the first floor.
Story	A level or floor of a building containing a ceiling and floor. A double height or two [2] Story space references two [2] combined levels/floors of space.
Street Fronting Elevation	Building façades facing onto a public right-of-way, MBB, or public open space.
Street Wall	The aggregate effects of the façades of buildings along a property line adjacent to a street or open space. The typical context for this term is in defining the public realm and framing or engaging the street.
Temporary Sign	Construction signs, super graphics applied to construction barricades, fences, project signs, or other temporary structures providing project graphics, development names, consultant information, or residential sales information.
Terrace	A raised, flat platform associated with and usually providing egress from a [usually residential] building.
Tower (High Rise)	Building with shared corridors and vertical circulation with a height greater than [120] ft.
Transparency	The degree of visibility through a building façade; or a characteristic of clear façade materials, such as glass, that provide an unhindered visual connection between the sidewalk and internal areas of the building.
Variation	A significant change or difference in form, proportion, position, condition, quantity, level, or other compositional characteristic. Variation describes adjacent elements comprising both similar and different attributes that are recognizable as related.
Vegetated Roof Covers	A roof of a building that is partially or completely covered with vegetation and a growing medium, planted over a waterproofing membrane.
View Corridor	A three-dimensional area extending out from a viewpoint. The width of the view corridor depends on the focus of the view. The focus of the view may be a single object, which would result in a narrow corridor, or a group of objects, such as a distinct skyline, which would result in a wide corridor.
Wall	Any building or structure wall area that is not transparent, including solid doors and mechanical area wall(s).
Wall Sign	A Sign painted directly on the Wall or mounted flat against a building wall with its copy or graphics parallel to the Wall to which it is attached and not protruding more than the thickness of the Sign.
Window Sign	A Sign painted or applied directly on the surface of a window glass or placed behind the surface of a window glass.

6.8 List of Figures

Figure 1.0a: Hunters Point Shipyard Phase 2 Site Location in San Francisco	2	Figure 4.4h: Building Height Exceptions Enclosed Amenity Area	63
Figure 1.1a: Hunters Point Shipyard and Candlestick Point Boundary	3	Figure 4.4i: Street Wall	64
Figure 1.4a: Project History And Timeline	8	Figure 4.4j: Implied Façade	64
Figure 2.1a: HPS2 Illustrative Plan	20	Figure 4.4k: Covered Outdoor Seating	64
Figure 3.0a: Districts and Features	28	Figure 4.4l: Street Wall Requirements	65
Figure 3.1a: Warehouse District	31	Figure 4.4m: Building Sizes: S, M, L, XL	66
Figure 3.2a: Village Center	33	Figure 4.5a: Floor Plate Area and Maximum Plan Length	67
Figure 3.3a: Wharf District	35	Figure 4.5b: Maximum Plan Length	67
Figure 3.4a: North Shoreline	37	Figure 4.6a: Building A	70
Figure 3.5a: Key Destinations and Features - Green Room	38	Figure 4.6b: Building B	70
Figure 3.6a: Key Destinations and Features - Water Room	39	Figure 4.6c: Block to Block Variation (Adjacent Block Facades Shall be Distinct from Block A)	71
Figure 3.7a: Key Destinations and Features - Pedestrian Allée	40	Figure 4.6d: Block A (Vertical Articulation and Material Color) Block B (Horizontal Articulation and Material Color)	71
Figure 3.8a: Key Destinations and Features - Waterfront Open Spaces	41	Figure 4.6e: Horizontal Shift	72
Figure 4.0a: Anticipated Development Map	45	Figure 4.6f: Vertical Shift	72
Figure 4.1a: Mid-Block Break Lot Divisions	50	Figure 4.6g: Angular Shift	74
Figure 4.1b: Mid-Block Break Width and Locations	51	Figure 4.6h: Framing	74
Figure 4.1c: Type 1 Mid-Block Break Width (40')	52	Figure 4.6i: Double Skin	74
Figure 4.1d: Type 1 Mid-Block Break Width (40')	52	Figure 4.6j: Structural Expression	74
Figure 4.1e: Type 2 Mid-Block Break Width (50')	53	Figure 4.7a: Significant Building Breaks A	82
Figure 4.1f: Type 2A Mid-Block Break Width (50')	53	Figure 4.7b: Significant Building Breaks B	82
Figure 4.1g: Type 3 and 4 Mid-Block Break Width (40' - 50')	54	Figure 4.7c: Stepback Requirements by Building Height	84
Figure 4.1h: Type 4 Mid-Block Break Width (50')	54	Figure 4.7d: Average Minimum Stepback	84
Figure 4.2a: Building Setback	56	Figure 4.7e: Minimum Length Of Stepback	84
Figure 4.2b: Setback Requirements	57	Figure 4.7f: Example of FV1 Horizontal Variations A	86
Figure 4.2c: View Looking South	58	Figure 4.7g: Example of FV1 Horizontal Variations B	86
Figure 4.2d: View Facing North	58	Figure 4.7h: Example of FV2 Vertical Variations A	87
Figure 4.3a: Developable Area Coverage Residential & Residential Mixed-Use Building	59	Figure 4.7i: Example of FV2 Vertical Variations B	87
Figure 4.3b: Developable Area Coverage Non-Residential Building	59	Figure 4.8a: BE1 - Apply One Additional Bulk/Massing Control (Example: Significant Breaks + Upper Floors Stepback)	89
Figure 4.4a: Building Height	60	Figure 4.8b: BE2A - Courtyard/Atria A or B	89
Figure 4.4b: Building Height On Slope	60	Figure 4.8c: BE2B - Courtyard/Atria A + B	89
Figure 4.4c: Maximum Building Height	61	Figure 4.8c: BE3 - Provide Visual and Physical Access to Interior Courtyard and/ or Atrium	89
Figure 4.4d: Building Stepback	62	Figure 4.8d: BE4 - Permanently Public Access to Open Space	89
Figure 4.4e: Building Stepback	62		
Figure 4.4f: Penthouse Structure Requirements	63		
Figure 4.4g: Building Height Exception	63		

Figure 4.8e:	BE5 - Reduction in Floor Plate Area of Upper Floors	90	Figure 4.19l:	Location of the Village Center	121
Figure 4.8f:	BE6 - Expressive Entrance	90	Figure 4.19m:	Material Palette	121
Figure 4.8g:	BE7 - Increased Transparency	90	Figure 4.21a:	Maximum Parking Requirements	124
Figure 4.8h:	BE8 - Distinct Corner Architectural Feature	90	Figure 4.21b:	Car Share Parking Space Requirements	124
Figure 4.8i:	BE9 - Roof Expression	91	Figure 4.21c:	Off-Street Freight Loading Space Requirements	125
Figure 4.8j:	BE10 - Additional Active Entrances	91	Figure 4.21d:	Off-Street Fright Loading Space Limits	125
Figure 4.8k:	PE1 - Public Access through the Building	91	Figure 4.22a:	Skyway Connections	127
Figure 4.8l:	PE2 - Public Access through Open Space Connection	91	Figure 4.23a:	Green Room Datum	128
Figure 4.9a:	Flexible Tower Zone	92	Figure 4.24a:	Existing Structures	131
Figure 4.9b:	Tower Floor Plate	92	Figure 4.26a:	Setback Zone 1 (0' Min./0' Max.)	136
Figure 4.9c:	Tapered Tower Example	93	Figure 4.26b:	Setback Zone 2 Variation 1 (0' Min./5' Max.)	137
Figure 4.9d:	Sculpted Tower Example	93	Figure 4.26c:	Setback Zone 2 Variation 2 (0' Min./5' Max.)	138
Figure 4.9e:	Stepped Tower Example	93	Figure 4.26d:	Setback Zone 3 (5' Min./10' Max.)	139
Figure 4.9f:	Facade Articulation Tower Example	93	Figure 4.26e:	Setback Zone 4 (7' Min./7' Max.)	140
Figure 4.10a:	Projections	94	Figure 4.26f:	Setback Zone 5 (10' Min./15' Max.)	141
Figure 4.11a:	Bicycle Room	96	Figure 4.26g:	Setback Zone 6 (15' Min./15' Max.)	142
Figure 4.11b:	Active Entrances Calculation	97	Figure 4.27a:	Type 1 Residential Mid-Block Break	145
Figure 4.11c:	Active Use Percentage Calculation	98	Figure 4.27b:	Type 1 Commercial Mid-Block Break	145
Figure 4.11d:	Ground Floor Activation Requirements	99	Figure 4.30a:	Sign Area Calculation Diagram	151
Figure 4.11e:	Ground Floor Transparency Calculation	100	Figure 4.30b:	Building Wall Sign	152
Figure 4.11f:	Ground Floor Activation Zone Chart	101	Figure 4.30c:	Entry Wall Sign	152
Figure 4.11g:	Ground Floor Activation Type Chart	102	Figure 4.30d:	Projecting Sign	153
Figure 4.13a:	Parking Ingress and Egress Per Block	104	Figure 4.30e:	Window Signs	154
Figure 4.13b:	Parking and Service Entrances	105	Figure 4.30f:	Freestanding Signs	155
Figure 4.17a:	Ground Floor Blank Walls Calculation	112	Figure 4.30g:	Directional Signs	155
Figure 4.17b:	Upper Floor Blank Walls Calculation	112	Figure 4.30h:	Awning Signs Zones	156
Figure 4.18a:	Residential Daylight	113	Figure 4.30i:	Canopy Signs	156
Figure 4.18b:	Commercial Daylight Option 1	113	Figure 4.30j:	Address or Nameplate Signs	157
Figure 4.18c:	Commercial Daylight Option 2	113	Figure 4.31a:	Temporary Barricade Graphics Zones	158
Figure 4.19a:	Material Palette	115	Figure 4.31b:	Portable Signs Placement Zones	159
Figure 4.19b:	Location of Water Room	116	Figure 4.33a:	Private Infrastructure	160
Figure 4.19c:	Material Palette	116			
Figure 4.19d:	Location of Development Perimeter	117			
Figure 4.19e:	Material Palette	117			
Figure 4.19f:	Location of Green Room	118			
Figure 4.19g:	Material Palette	118			
Figure 4.19h:	Location of Research District and Transit Hub	119			
Figure 4.19i:	Material Palette	119			
Figure 4.19j:	Location of Pedestrian Allée	120			
Figure 4.19k:	Material Palette	120			

6.9 Image Credits

1 INTRODUCTION

P2

Figure 1.0a Hunters Point Shipyard Site Location in San Francisco
Satellite Image of San Francisco;
Copyright Google Earth

P.08

Figure 1.4a Project History and Timeline

The Ohlone
Courtesy of the Library of Congress

Chinese Shrimp Camps
Courtesy of the Library of Congress

California Dry Dock Co.
Courtesy of the Library of Congress

P.09

Figure 1.4a Project History and Timeline

Navy Expansion
Courtesy of the Library of Congress

P.12-13

1-3. Archival images of the working shipyard
Courtesy of the Library of Congress

2 VISION

P.16

View of the Site towards the Grunning Crane
Photo by Vittoria Zupicich

P.18-19

1. Shipyard Existing Aerial Photo
Photo by Henrik Kam

2. Shipyard Historic Photos
Courtesy of the Library of Congress

3. Shipyard Existing Photo
Photo by Henrik Kam

4. Shipyard Future Development Example
Copyright Getty Images

P.22 - 23

1. Adaptive Reuse Example
Urban Outfitters Corporate Campus, Philadelphia
Photo by Christopher Leaman

2. New Building Example
Małopolska Garden of Arts by Ingarden & Ewý Architects
Photo by Krzysztof Ingarden

3 Shipyard Existing Photo
Photo by Henrik Kam

4. Waterfront Open Space Example
Dusseldorf Waterfront
Sourced: OEBC Online Magazine

P.24 - 25

1. Residential Neighborhood Example
Witte de Withstraat, Rotterdam
Photo by Alamy

4. Office through Adaptive Reuse Example
Photo by Jasper Sanidad

5. Ground Floor Retail Example
Santana Row, San Jose
Photo by Igor Starkov

3. DISTRICTS, KEY DESTINATIONS AND FEATURES

P.30

1. Building 813
Photo by Vittoria Zupicich

2. Building 351

Photo by Vittoria Zupicich

3. Building 411
Photo by Vittoria Zupicich

P.31

1. Mid-Rise Residential Example
Courtesy of Sellen Construction

2. Open Space Example
Sourced: Shutterstock

P.32

1. Building 101
Photo by Angela Lin, Square One Productions

P.33

1. Artists' Studios Examples
Creative Commons

2. Artists' Studios Examples
Building 18 Anthropologie's Headquarter, Philadelphia
Photo by Christopher Leaman

3. Maker Space Examples
TechShop, Brooklyn
Photo by Dana Gordon

P.34

1. Building 231
Copyright Google Streetview

3. Building 253
Photo by Vittoria Zupicich

P.37

1. Residential Tower Example
Gensler rendering

2. Residential Example
Copyright Google Street View

P.38

1. Green Room Examples
Photo by Connie Zhou

2. Green Room Examples
Photo by Jean-Christophe Benoist

P.39

2. Water Room Examples
Photo by Tomasz Majewski

P.40

1. Pedestrian Allee Examples
Copyright Getty Images

P.41

2. Waterfront Open Space Examples
Sourced: Shutterstock

4 BUILDING DESIGN STANDARDS AND GUIDELINES**P. 64**

Figure 4.4j: Implied Facade
Copyright Google Streetview

P. 70

Figure 4.6a: Building A
400 Grove Street, San Francisco
Photo by Riki Nishimura

Figure 4.6b: Building B
333 Brannan St., San Francisco
Photo by Riki Nishimura

P.73

1. Horizontal Shift Example
Strato, Paris by Hardel and Le Bihan
Architectes
Photo by Vincent Fillon

2. Horizontal Shift Example
1180 Fourth Street, San Francisco
Photo by Riki Nishimura

3. Vertical Shift Example
Copyright Getty Images

4. Vertical Shift Example
LPA O&M Dogpatch
Photo by Riki Nishimura

5. Vertical Shift Example
Copyright Getty Images

P.75

1. Double Skin Example
Wexford County Council by Robin
Lee Architecture
Photo by Andrew Lee with Robin Lee
Architects

2. Angular Shift Example
Getty Images

3. Structural Expression Example
388 Protreto Ave., San Francisco
Photo by Riki Nishimura

4. Angular in Shift Example
400 Grove, San Francisco
Photo by Riki Nishimura

5. Framing Example
Odin Apartment Building, Seattle
Copyright Google Street View

P.76

1. Punched Openings
130 William Street, New York by
Adjaye Associates
Rendering from Adjaye Associates

2. Architectural Fins
Copyright Getty Images

3. Balconies Example
Copyright Getty Images

P.77

1. Vertical Recesses and Punched
Openings Example
Copyright Getty Images

2. Architectural Fins and Louvers
Example
Copyright Google Streetview

3. Punched Openings Example
Copyright Getty Images

4. Balconies Extension and Recesses
Example
609 Oak Street, Oakland
Copyright Google Images Reuse

6. Shading Devices and Cornice
Example
1180 Fourth Street, San Francisco
Photo by Riki Nishimura

P.79

1. Punched Windows Example
Copyright Getty Images

2. Punched Windows + Curtain Wall
Example
333 Brannan St., San Francisco
Photo by Riki Nishimura

3. Punched Windows Example
Candlestick Point Block 2A, San
Francisco
Rendering courtesy of FivePoint

4. Curtain Wall Example
PNC Place, Washington, D.C. by
Gensler

5. Curtain Wall and Atrium Example
Copyright Getty Images

6. Curtain Wall with Boxed Windows
Example
Copyright Getty Images

7. Window Wall Example

333 Brannan St., San Francisco

Photo by Riki Nishimura

8. Double Skin Example

Copyright Getty Images

P.80

1. Materials and Colors as a Volumetric Application Example

Copyright Google Street View

2. Metal Used as Monolithic Application Example

588 Mission Street, San Francisco

Photo by Riki Nishimura

3. Brick as Organizing Element Example

Chanel Mission Bay, San Francisco

Photo by Riki Nishimura

4. Character-defining Façade

Composition Example

WOZOCO by MVRDV, Amsterdam

Photo by Paul Brouns

P.83

1. Significant Break Examples

333 Brannan St., San Francisco

Photo by Riki Nishimura

2. Significant Break Examples

680 Indiana Ave., San Francisco

Photo by Riki Nishimura

P.83

1. Upper Floor Building Step Back

Meridian Building, Wellington by

Studio Pacific Architecture

Photo by Simon Devitt

P.87

1. Façade Variation FV1 Horizontal

Copyright Getty Images

2. Façade Variation FV2 Vertical

Copyright Getty Images

P.93

1. Tapered Tower Example

Copyright Sedmak, Dreamstime.com

3. Stepped Tower Example

Copyright Getty Images

4. Façade Articulation Tower Example

Rendering from Adjaye Associates

P.96

1. Active Bicycle Storage Examples

Photo by Ryan Gobuty

2. Active Bicycle Storage Examples

Photo by Riki Nishimura

P.100

1. Ground Floor Transparency

Examples

Photo by Matthew Millman

2. Ground Floor Transparency

Examples

Photo by Scott Frances

P.103

1. Clearly Defined Building Entry

Example

Photo by Connie Zhou

2. Primary Building Entry Example

Photo by Riki Nishimura

3. Entry to Residential Example

Copyright Google Street View

P.106

1. Metal Screening Example

Copyright Getty Images

P.109

2. Lighting at Parking Garage

Example

Courtesy of May + Russel Architects

P.110

3. Roof With Mechanical Equipment

Example

Copyright Getty Images

P.129

1. Cornice Creates Datum Example

Copyright Getty Images

2. Datum: Change In Architectural Articulation / Modulation Example

Copyright Getty Images

3. Datum: Change In Material and Plane Example

Photo by Riki Nishimura

4. Datum: Canopy Example

Copyright Getty Images

5. Datum: Change In Color and Plane Example

Courtesy of KTG Architecture and Planning

6. Datum: Change In Transparency Example

Photo by Prakash Patel

P. 130

1. Adaptive Reuse for Example

Małopolska Garden of Arts by

Ingarden & Ewý Architects

Photo by Krzysztof Ingarden

2. Adaptive Reuse Example

Copyright Gensler

P. 135

1. Private Common Open Space -

Rooftop Example

Copyright Getty Images

P. 147

1-16. Signage Examples

Photos by Tom Horton

P. 149

1. Digital Display Sign Example

Photo by Tom Horton

P. 158

1. Temporary Signs Example
Photo by Tom Horton

P. 159

1. Portable Signs Example
Photo by Tom Horton

P. 161

1. Entrances and Ground Level
Lighting Examples
Photo by Nic Lehoux

2. Entrances and Ground Level
Lighting Examples
Photo by Christa Lachenmaier



FIVEPOINT

Adjaye Associates

Gensler