

**COMMISSION ON COMMUNITY INVESTMENT AND INFRASTRUCTURE**

**RESOLUTION NO. 71-2015**

*Adopted November 3, 2015*

**APPROVING AMENDMENTS TO THE MISSION BAY SOUTH DESIGN FOR DEVELOPMENT IN CONNECTION WITH A GOLDEN STATE WARRIORS EVENT CENTER AND MIXED-USE DEVELOPMENT ON BLOCKS 29-32 IN MISSION BAY SOUTH; MISSION BAY SOUTH REDEVELOPMENT PROJECT AREA**

WHEREAS, On September 17, 1998, by Resolution No. 190-98, the Commission of the former Redevelopment Agency of the City and County of San Francisco (“Redevelopment Agency”) approved the Redevelopment Plan for the Mission Bay South Redevelopment Project Area (“Plan”). On the same date, the Redevelopment Agency Commission adopted related documents, including Resolution No. 193-98 authorizing execution of an Owner Participation Agreement (“South OPA”) and related documents between Catellus Development Corporation, a Delaware corporation (“Catellus”), and the Redevelopment Agency. On November 2, 1998, the San Francisco Board of Supervisors (“Board of Supervisors”), by Ordinance No. 335-98, adopted the Plan. The Plan and its implementing documents, as defined in the Plan, constitute the “Plan Documents”; and,

WHEREAS, Catellus, the original master developer of the Mission Bay North and South Redevelopment Project Areas, has sold most of its remaining undeveloped land in Mission Bay to FOCIL-MB, LLC, (“FOCIL-MB”), a subsidiary of Farallon Capital Management, LLC, a large investment management firm. The sale encompassed approximately 71 acres of land in Mission Bay, and the remaining undeveloped residential parcels in Mission Bay South. FOCIL-MB assumed all of Catellus’s obligations under the South OPA and the Redevelopment Agency’s Owner Participation Agreement for Mission Bay North (collectively, the “OPAs”), as well as all responsibilities under the related public improvement agreements and land transfer agreements with the City and County of San Francisco (“City”); and,

WHEREAS, On February 1, 2012, state law dissolved the former Redevelopment Agency and required the transfer of certain of its assets and obligations to the Successor Agency to the Redevelopment Agency (“Successor Agency”), commonly known as the Office of Community Investment and Infrastructure (“OCII”), and on June 27, 2012, state law clarified that successor agencies are separate public entities, Cal. Health & Safety Code §34170 *et seq.* (“Redevelopment Dissolution Law”); and,

WHEREAS, Redevelopment Dissolution Law required creation of an oversight board to the successor agency and provided that with approval from its oversight board and the State Department of Finance (“DOF”), a successor agency may continue to implement “enforceable obligations” such as existing contracts, bonds and leases, that were executed prior to the suspension of redevelopment agencies’ activities. On January 24, 2014, DOF finally and conclusively determined that the Mission Bay North and South Owner Participation Agreements and Mission Bay Tax

Increment Allocation Pledge Agreements are enforceable obligations pursuant to Health and Safety Code Section 34177.5(i); and,

WHEREAS, On October 2, 2012, the Board of Supervisors of the City, adopted Ordinance No. 215-12 (the "Implementing Ordinance"), which Implementing Ordinance was signed by the Mayor on October 4, 2012, and which, among other matters: (a) acknowledged and confirmed that the Successor Agency is a separate legal entity from the City, and (b) established this Commission (this "OCII Commission") and delegated to it the authority to (i) act in place of the Redevelopment Agency Commission to, among other matters, implement, modify, enforce and complete the Redevelopment Agency's enforceable obligations, (ii) approve all contracts and actions related to the assets transferred to or retained by the Successor Agency, including, without limitation, the authority to exercise land use, development, and design approval, consistent with applicable enforceable obligations, and (iii) take any action that the Redevelopment Dissolution Law requires or authorizes on behalf of the Successor Agency and any other action that this OCII Commission deems appropriate, consistent with the Redevelopment Dissolution Law, to comply with such obligations. The Implementing Ordinance is incorporated herein by reference; and,

WHEREAS, The Board of Supervisors' delegation to this Commission includes the authority to grant approvals under specified land use controls for the Mission Bay Project consistent with the approved Plan and enforceable obligations, including amending the Plan and related documents; and,

WHEREAS, The Design for Development was originally adopted by the former Redevelopment Agency Commission on September 17, 1998 (Resolution No. 191-98), and amended on February 17, 2004 (Resolution No. 24-2004), March 16, 2004 (Resolution No. 34-2004), and March 17, 2015 (Resolution No. 15-2015); and,

WHEREAS, The Design for Development sets forth certain design standards and guidelines for development of buildings within the Plan Area, including standards related to building height and bulk, tower location and separation, streetwalls and setbacks, parking and loading, view corridors and signage; and,

WHEREAS, Mission Bay South Blocks 29-32 are currently owned by GSW Arena LLC ("GSW"), an affiliate of the Golden State Warriors, LLC, which owns and operates the Golden State Warriors National Basketball Association team and is bound by the terms of the South OPA; and,

WHEREAS, GSW proposes to construct a multi-purpose event center and a variety of mixed uses, including office, retail, open space and structured parking on an approximately 11-acre site on Blocks 29-32 in Mission Bay (the "Event Center Project"). The Project site is bounded by South Street on the north, Third Street on the west, 16th Street on the south, and by the future planned realigned Terry A. Francois Boulevard on the east; and,

WHEREAS, OCII proposes an amendment to the Design for Development for an Event Center Project that would address the unique design features of the Event Center and its integration into the remainder of Blocks 29-32 and the surrounding neighborhood, which amendments are attached hereto as Exhibit A and incorporated herein (the "D for D Amendments"); and,

WHEREAS, The D for D Amendments comply with the land use controls of the Plan and are consistent with the Plan's redevelopment objectives; and,

WHEREAS, The Successor Agency is the lead agency that administers environmental review for private projects in Mission Bay North and South Redevelopment Plan Areas in compliance with the requirements of CEQA; and,

WHEREAS, On June 5, 2015, OCII released for public review and comment the Draft Subsequent Environmental Impact Report for the Project (OCII Case No. ER-2014-919-97, Planning Department Case No. 2014.1441E, State Clearinghouse No. 2014112045, the "GSW DSEIR"). This document is tiered from the certified Mission Bay Final Subsequent Environmental Impact Report that the Redevelopment Agency and City and County of San Francisco certified on September 17, 1998 (State Clearinghouse No. 7092068, the "Mission Bay SEIR"). The Mission Bay SEIR document provided programmatic environmental review of the overall Mission Bay Redevelopment Plan (consisting of approximately 300-acre Mission Bay North and South Redevelopment Plan Areas); and,

WHEREAS, OCII prepared a Final Subsequent Environmental Impact Report ("FSEIR") for the Project consisting of the GSW DSEIR, the comments received during the review period, any additional information that became available after the publication of the GSW DSEIR, and the Responses to Comments document, all as required by law; and,

WHEREAS, On November 3, 2015, the Commission reviewed and considered the FSEIR and, by Resolution No. 69-2015, certified the completion of the FSEIR for the Project; and

WHEREAS, In accordance with the approval of the D for D Amendments contemplated by this Resolution, this Commission adopted Resolution No.71-2015 making findings under the California Environmental Quality Act (California Public Resources Code sections 21000 et seq.) regarding the alternatives, mitigation measures and significant environmental impacts analyzed in the FSEIR, and adopting mitigation measures and a mitigation monitoring and reporting program, and a statement of overriding considerations, and rejecting infeasible alternatives(the "FSEIR Findings"). A copy of such Resolution is on file with the Secretary of this Commission and is incorporated herein by reference; and

WHEREAS, OCII staff has prepared the proposed D for D Amendments and finds them acceptable and recommends approval thereof; and, now, therefore, be it

RESOLVED, That the Commission finds and determines that the proposed D for D Amendments are within the scope of the Project analyzed in the FSEIR; and be in further

RESOLVED, That the Commission approves the D for D Amendments in the form attached to this Resolution as Exhibit A.

I hereby certify that the foregoing resolution was adopted by the Commission at its meeting of November 3, 2015.

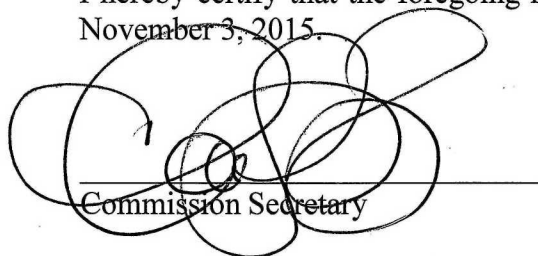

Commission Secretary

Exhibit A: Design for Development Amendments

# DESIGN FOR DEVELOPMENT

FOR THE MISSION BAY SOUTH PROJECT AREA

ORIGINAL DOCUMENT APPROVED  
BY THE REDEVELOPMENT AGENCY COMMISSION  
RESOLUTION No. 191-98, SEPTEMBER 17, 1998

AMENDMENTS APPROVED  
BY THE REDEVELOPMENT AGENCY COMMISSION  
RESOLUTION No. 24-2004, FEBRUARY 17, 2004  
RESOLUTION No. 34-2004 MARCH 16, 2004

AMENDMENTS APPROVED  
BY THE COMMISSION ON COMMUNITY INVESTMENT AND INFRASTRUCTURE  
RESOLUTION No. 13-2015, MARCH 17, 2015

PROPOSED AMENDMENTS TO BE APPROVED  
BY THE COMMISSION ON COMMUNITY INVESTMENT AND INFRASTRUCTURE  
NOVEMBER 3, 2015

SOUTH



---

## TABLE OF CONTENTS

I. Introduction .....	7
II. Definition of Terms .....	9
III. Design Standards .....	18
Introduction .....	19
Maximum Development .....	20
Height.....	22
Bulk .....	26
Setbacks .....	27
Open Space.....	34
Sunlight .....	36
Wind .....	38
View Corridors.....	39
Street System.....	40
Parking.....	42
Loading .....	44
Signage .....	45
IV. Design Guidelines .....	46
A. Open Space Guidelines .....	48
B. Residential Guidelines .....	58
C. Commercial Industrial Guidelines .....	72
D. Retail Guidelines .....	84
E. Hotel Guidelines .....	94
F. Parking Guidelines .....	100
G. Street Guidelines .....	108
V. CAC Design Objectives .....	118

---

## LIST OF MAPS AND FIGURES

### Maps

1. Plan Boundary, Development Block and Street Grid .....	7
2. Land Use Plan .....	20
3. Plan Boundary, Development Block and Street Grid .....	21
4. Height .....	22
5. Required Setbacks .....	27
6. Primary Streets for Streetwalls .....	29
7. Neighborhood Streets for 55' Average Height .....	30
8. Open Space .....	35
9. Shadow Analysis: Open Space .....	37
10. Street Hierarchy .....	41

### Figures

1. Residential Districts Height Diagram .....	24
2. Commercial Industrial Districts Height Diagram .....	24
3. Corners .....	25
4. Tower Location on Third Street .....	25
5. Commercial Tower Separation .....	25
6. Residential Tower Separation .....	25
7. Measuring Building Height - Flat Roof .....	25
8. Measuring Building Height - Pitched or Stepped Roof .....	25
9. Bulk .....	26
10. Minimum Lot Coverage Examples .....	31
11. Minimum Block Streetwall Length on a Block .....	31
12. Streetwall Variation Examples .....	32
13. Required Stepbacks in HZ5 for Blocks 26 & 26A .....	33
14. Corner Zone Conditions .....	33
15. Urban Design Framework .....	47
16. Mission Bay South Open Space .....	49
17. Rooftop Community Structures .....	56
18. Mission Bay South Residential .....	59
19. Mid-block Walkway Examples on Blocks 12 & 13 .....	60
20. View Corridor .....	61
21. Streetwall Setbacks .....	62
22. Additional Setback for Mid-block Lanes .....	62
23. Residential Entries .....	64
24a. Prominent Residential Entries .....	64
24b. Prominent Residential Entries .....	64
25. Vertical Articulation .....	65
26. Tower Articulation: Stepback .....	66

---

## LIST OF MAPS AND FIGURES CONT'D

(Figures Cont'd)

27. Tower Articulation: Notch .....	66
28. Building Base .....	67
29. Tower Placement .....	67
30. Architectural Details Create Visual Interest .....	69
31. Base, Shaft, Capital .....	70
32. Build to Corner.....	71
33. Mark Corners .....	71
34. Corner Pass Throughs .....	71
35. Mission Bay South Commercial Industrial .....	73
36. View to Bay .....	74
37. View to City .....	74
38. Ground Floor Open Space .....	75
39. Building Variety on Terry Francois Blvd. ....	76
40. Streetwall Height .....	77
41. Pedestrian Scale on Blank Walls .....	77
42. Lower Elements at Building Frontage .....	80
43. Open Space/Panorama.....	80
44. Tower Placement.....	80
45. Screen Mechanical Equipment.....	81
46. Architectural Variety Creates Visual Interest .....	82
47. Base, Shaft, Capital .....	82
48. Variety along Bayfront Park.....	83
49. Neighborhood Retail .....	87
50. Corner Store .....	88
51. City-Serving Retail Locations .....	90
52. Visually Interesting Pedestrian Scale .....	91
53. Mission Bay South Hotel.....	95
54. Open Space with Adjacent Active Uses .....	96
55. Open Space with Adjacent Retail Frontage.....	96
56. Base, Shaft, Capital .....	99
57. Architectural Variety Creates Visual Interest .....	99
58. Residential Buffer for Parking .....	102
59. Landscape Buffer for Parking .....	102
60. Roof Terraces.....	104
61. Texture Solid Walls .....	106
62. 4th Street .....	109
63. 3rd Street .....	109
64. Owens Street Near Channel .....	110
65. Owens Street Setback Commons to 16th Street .....	110

---

LIST OF MAPS AND FIGURES CONT'D

(Figures Cont'd)

66. 16th Street .....111  
67. Terry Francois Boulevard .....112  
68. Mariposa Street .....112  
69. Mission Bay Boulevard .....113  
70. East-West Residential.....113  
71. Sidewalk Section .....114  
72. Corner Widening.....115

# I . I n t r o d u c t i o n

# I. INTRODUCTION

The Redevelopment Plan ("Redevelopment Plan") for the Mission Bay South Redevelopment Project, as approved by the San Francisco Board of Supervisors, establishes the basic land use standards for the Mission Bay South Plan Area ("Plan Area"), and includes general objectives, including planning objectives, that apply to the Plan Area. This Mission Bay South Design for Development ("Design for Development") is a companion document containing Design Standards and Design Guidelines which apply to all development within the Plan Area. The Redevelopment Plan and this Design for Development supersede the San Francisco Planning Code in its entirety, except as otherwise provided in the Redevelopment Plan. In the event of any conflict between this Design for Development and the Redevelopment Plan, the Redevelopment Plan provisions shall control. The Redevelopment Agency Commission may also enter into one or more owner participation agreements related to development projects in the Plan Area. Such agreements may contain design guidelines as well as design review and document approval procedures.

Section II. of this Design for Development Document contains a listing of definitions used in this document. Section III. contains Design Standards that govern development of the Plan Area. Section IV. consists of Design Guidelines that apply to the Plan Area. Section V. contains, for informational purposes, Design Objectives that were adopted by the Mission Bay Citizen's Advisory Committee (CAC).

Plan Boundary,  
Development Block and Street Grid Map



Map 1

## 11. Definition of Terms



## II. DEFINITION OF TERMS

---

The following definitions apply to certain terms used in this Design for Development.

### **Articulation:**

Variation in the massing, setback, height, or design features of a building, such as vertical recesses, changes in wall plane, changes in apparent height, changes in materials and colors, changes in facade recesses and projections, changes in floor levels, changes in roof forms, parapets, or cornice treatments, changes in the shape and location of garage and residential entries, or changes in window forms and patterns.

### **Awning:**

A light roof-like structure, supported entirely by the exterior wall of a building; consisting of a fixed or movable frame covered with cloth, plastic or metal; extending over doors, windows, and/or show windows; with the purpose of providing protection from sun and rain and/or embellishment of the facade; as further regulated in Sections 4506 and 5211 of the San Francisco Building Code (in effect as of the adoption of this Design for Development).

### **Base Height:**

The first tier in the overall height of buildings within the Plan Area as prescribed in the Height Zone Chart and Diagram included herein, **and which includes an Event Center up to 135 feet in height.**

### **Block:**

An area of land as designated numerically on the Plan Boundary, Development Block and Street Grid map.

### **Building:**

Any structure having a roof supported by columns or walls intended for permanent occupancy.

### **Building Base:**

Architectural term used in the guidelines to describe the portion of a building typically consisting of the first two floors and usually associated with its relationship to human scale.

### **Building Height:**

Building height is the vertical distance between finished grade and the top of a building. The allowable height of a building is specified by the Height Zone in which the building is located. Building top is defined as the top of the finished roof in the case of a flat roof, and the average height of the rise in the case of a pitched or stepped roof (See Figs. 7 & 8 on p.21). On a sloping site, this measurement is taken at the median grade height for each building face. Total building height is calculated by determining the average height of all individual building faces. Exemptions to building height include:

- Mechanical equipment and appurtenances necessary to the operation or maintenance of the building.
- Enclosed space related to the recreational and/or community use of the roof, not to exceed 20 feet in height above the roof level.
- Ornamental and symbolic features of buildings, including towers, spires, cupolas, domes, where such features are not used for human occupancy.

---

**Bulk:**

These standards specify the maximum physical dimensions of upper stories of new buildings, above 90 feet. Standards include: maximum diagonal, maximum plan dimension, and maximum floor plate area.

**Canopy:**

A light roof-like structure, supported by the exterior wall of a building and on columns or wholly on columns, consisting of a fixed or movable frame covered with approved cloth, plastic or metal, extending over entrance doorways only, with the purpose of providing protection from sun and rain and embellishment of the facade, as further regulated in Sections 4504, 4506, 4508, and 5213 of the San Francisco Building Code (in effect as of the adoption of this Design for Development).

**City Serving Retail:**

A retail use that is designed to draw customers from the entire city.

**Connector:**

Term used to describe a pedestrian path along a street linking open spaces within Mission Bay.

**Corner:**

The first fifty feet of a block measured from the intersection of two or more streets.

**Court:**

Any space on a lot other than a yard which, from a point not more than two feet above the floor line of the lowest story in the building on the lot in which there are windows from rooms abutting and served by the court, is open and unobstructed to the sky, except for obstructions permitted herein. An "outer court" is a court, one entire side or end of which is bounded by a front setback, a rear yard, a side yard, a front lot line, a street, or an alley. An "inner court" is any court which is not an outer court.

**Developable Area:**

Developable Area shall be the net area of land excluding dedicated streets, public open space, and view corridors.

**Dwelling Unit:**

A room or suite of two or more rooms that is designed for residential occupancy for 32 consecutive days or more, with or without shared living spaces, such as kitchens, dining facilities or bathrooms.

**Event Center:**

A primarily indoor structure located on Blocks 29-32 having tiers of seats rising around a central court, field, or stage, intended for assembly and entertainment or other public use purposes and which may include such accessory uses as snack bars, restaurants, retail sales, team and facility administration offices, sports team practice facilities, media/broadcasting functions and other support facilities, and may include below-grade or podium parking facilities.

**Event Center Project:**

A mixed-use project located on Blocks 29-32 that includes an Event Center.

**Facade:**

Exterior walls of a building which are adjacent to or front on a street, mid-block walkway, park, or plaza.

**Floor Area, Gross**

The sum of the gross areas of the several floors of a building or buildings, measured from the exterior faces of exterior walls or from the centerlines of walls separating two buildings. Where columns are outside and separated from an exterior wall (curtain wall) which encloses the building space or are otherwise so arranged that the curtain wall is clearly separate from the structural members, the exterior face of the curtain wall shall be the line of measurement, and the area of the columns themselves at each floor shall also be counted.

- A Except as specifically excluded in this definition, "gross floor area" shall include, although not be limited to, the following:
- 1 Basement and cellar space, including tenants' storage areas and all other space except that used only for storage or services necessary to the operation or maintenance of the building itself;
  - 2 Elevator shafts, stairwells, exit enclosures and smokeproof enclosures, at each floor;
  - 3 Floor space in penthouses except as specifically excluded in this definition;
  - 4 Attic space (whether or not a floor has been laid) capable of being made into habitable space;
  - 5 Floor space in balconies or mezzanines in the interior of the building;
  - 6 Floor space in open or roofed porches, arcades or exterior balconies, if such porch, arcade or balcony is located above the ground floor or first floor of occupancy above basement or garage and is used as the primary access to the interior space it serves;
  - 7 Floor space in accessory buildings, except for floor spaces used for accessory off-street parking or loading spaces as described herein, and driveways and maneuvering areas incidental thereto; and
  - 8 Any other floor space not specifically excluded in this definition.
- B "Gross floor area" shall not include the following:
- 1 Basement and cellar space used only for storage or services necessary to the operation or maintenance of the building itself;
  - 2 Attic space not capable of being made into habitable space;
  - 3 Elevator or stair penthouses, accessory water tanks or cooling towers, and other mechanical equipment, appurtenances and areas necessary to the operation or maintenance of the building itself, if located at the top of the building or separated therefrom only by other space not included in the gross floor area;

- 
- 4 Mechanical equipment, appurtenances and areas, necessary to the operation or maintenance of the building itself (i) if located at an intermediate story of the building and forming a complete floor level; or (ii) if located on a number of intermediate stories occupying less than a full floor level, provided that the mechanical equipment, appurtenances and areas are permanently separated from occupied floor areas and in aggregate area do not exceed the area of an average floor as determined by the Redevelopment Agency
  - 5 Outside stairs to the first floor of occupancy at the face of the building which the stairs serve, or fire escapes;
  - 6 Floor space used for accessory off-street parking and loading spaces and drive-ways and maneuvering areas incidental thereto;
  - 7 Arcades, plazas, walkways, porches, breezeways, porticos and similar features (whether roofed or not), at or near street level, accessible to the general public and not substantially enclosed by exterior walls; and accessways to public transit lines, if open for use by the general public; all exclusive of areas devoted to sales, service, display, and other activities other than movement of persons;
  - 8 Balconies, porches, roof decks, terraces, courts and similar features, except those used for primary access as described in Paragraph (a)(6) above, provided that:
    - a If more than 70 percent of the perimeter of such an area is enclosed, either by building walls (exclusive of a railing or parapet not more than three feet eight inches high) or by such walls and interior lot lines, and the clear space is less than 15 feet in either dimension, the area shall not be excluded from gross floor area unless it is fully open to the sky (except for roof eaves, cornices or belt courses which project not more than two feet from the face of the building wall).
    - b If more than 70 percent of the perimeter of such an area is enclosed, either by building walls (exclusive of a railing or parapet not more than three feet eight inches high), or by such walls and interior lot lines, and the clear space is 15 feet or more in both dimensions, (1) the area shall be excluded from gross floor area if it is fully open to the sky (except for roof eaves, cornices or belt courses which project no more than two feet from the face of the building wall), and (2) the area may have roofed areas along its perimeter which are also excluded from gross floor area if the minimum clear open space between any such roof and the opposite wall or roof (whichever is closer) is maintained at 15 feet (with the above exceptions) and the roofed area does not exceed 10 feet in depth; (3) in addition, when the clear open area exceeds 625 square feet, a canopy, gazebo, or similar roofed structure without walls may cover up to 10 percent of such open space without being counted as gross floor area.
    - c If, however, 70 percent or less of the perimeter of such an area is enclosed by building walls (exclusive of a railing or parapet not more than three feet eight inches high) or by such walls and interior lot lines, and the open side or sides face on a yard, street or court whose dimensions satisfy the requirements of this Code and all other applicable codes for instances in which required windows face upon such yard, street or court, the area may be roofed to the extent permitted by such codes in instances in which required windows are involved;

## II. DEFINITION OF TERMS

---

- 9 On lower, nonresidential floors, elevator shafts and other life-support systems serving exclusively the residential uses on the upper floors of a building;
- 10 One-third of that portion of a window bay conforming to the requirements of Section 136(d)(2) of the San Francisco Planning Code (in effect as of the adoption of the Design for Development) which extends beyond the plane formed by the face of the facade on either side of the bay but not to exceed seven square feet per bay window as measured at each floor;
- 11 Ground floor area devoted to building or pedestrian circulation and building service;
- 12 Space devoted to personal services, restaurants, and retail sales of goods intended to meet the convenience shopping and service needs of workers and residents, not to exceed 5,000 occupied square feet per use and, in total, not to exceed 75 percent of the area of the ground floor of the building plus the ground level, on-site open space.
- 13 An interior space provided as an open space feature in accordance with the requirements herein;
- 14 Floor area devoted to child care facilities provided that:
  - a Allowable indoor space is no more or no less than 3,000 square feet and no more than 6,000 square feet, and
  - b The facilities are made available rent free, and
  - c Adequate outdoor space is provided adjacent, or easily accessible, to the facility. Spaces such as atriums, rooftops or public parks may be used if they meet licensing requirements for child care facilities, and
  - d The space is used for child care for the life of the building as long as there is a demonstrated need. No change in use shall occur without a finding by the Redevelopment Agency that there is a lack of need for child care and that the space will be used for a facility described herein dealing with cultural, educational, recreational, religious, or social service facilities;
- 15 Floor area permanently devoted to cultural, educational, recreational, religious or social service facilities available to the general public at no cost or at a fee covering actual operating expenses, provided that such facilities are:
  - a Owned and operated by a nonprofit corporation or institution, or
  - b Are made available rent free for occupancy only by nonprofit corporations or institutions for such functions. Building area subject to this subsection shall be counted as occupied floor area, except as provided herein, for the purpose of calculating the off-street parking and freight loading requirements for the project;
  - c For the purpose of calculating the off-street parking and freight loading requirement for the project, building area subject to this subsection shall be counted as occupied floor area, except as provided herein.

### **Floor Area, Leasable:**

Leasable Floor Area means Floor Rentable Area, as defined and calculated in the 1996 Building Owners Management Association International publication, "Standard Method For Measuring Floor Area in Office Buildings."

---

**Floor Area, Occupied:**

Floor area devoted to, or capable of being devoted to, a principal or conditional use and its accessory uses. For purposes of computation, "occupied floor area" shall consist of the gross floor area, as defined herein, minus the following:

- a Nonaccessory parking and loading spaces and driveways, and maneuvering areas incidental thereto;
- b Exterior walls of the building;
- c Mechanical equipment, appurtenances and areas, necessary to the operation or maintenance of the building itself, wherever located in the building;
- d Restrooms, and space for storage and services necessary to the operation and maintenance of the building itself, wherever located in the building;
- e Space in a retail store for store management, show windows and dressing rooms, and for incidental repairs, processing, packaging and stockroom storage of merchandise for sale on the premises; and
- f Incidental storage space for the convenience of tenants.

**Floor Area Ratio:**

The ratio of the gross floor area of buildings to the developable land area measured for Commercial Industrial, Commercial Industrial/Retail, and Retail areas as described in the Redevelopment Plan. In cases in which portions of the gross floor area of a building project horizontally beyond the lot lines, all such projecting gross floor area shall also be included in determining the floor area ratio. If the height per story of a building, when all the stories are added together, exceeds an average of 18 feet, then additional gross floor area shall be counted in determining the floor area ratio of the building, equal to the average gross floor area of one additional story for each 18 feet or fraction thereof by which the total building height exceeds the number of stories times 18 feet; except that such additional gross floor area shall not be counted in the case of live/work units or a church, theater or other place of public assembly.

**Frontage:**

Building width along a street, park, or plaza.

**Live/Work Unit:**

A building or portion of a building combining residential living space with an integrated work space principally used by one or more of the residents. Live/Work Units are subject to the same land use controls as Dwelling Units.

**Lot:**

A block, or subdivision thereof, that is under one ownership.

**Marquee:**

A permanent roofed structure attached to and supported entirely by a building; including any object or decoration attached to or part of said marquee; no part of which shall be used for occupancy or storage; with the purpose of providing protection from sun and rain or embellishment of the facade; as further regulated in Sections 414 and 4506 of the San Francisco

## II. DEFINITION OF TERMS

---

Building Code (in effect as of the adoption of this Design for Development).

**Massing:**

The exterior shape of a building or structure.

**Mid-block Lane:**

A pedestrian-oriented walkway through a development project.

**Midrise Height:**

The second tier in the overall height of buildings within the Plan Area as prescribed in the Plan Area Height Zone Charts and Diagrams.

**Modulation:**

Major variations in the massing, height, or setback of a building.

**Neighborhood-Serving Retail:**

Retail uses providing goods and services to a population within the immediate neighborhood. Also referred to as “local-serving” retail in the Redevelopment Plan.

**Parcel:**

Same as lot.

**Parking:**

A parking facility serving uses located on either parcels or blocks occupied by said facility or on other parcels or blocks.

**Plan Dimensions:**

The linear horizontal dimensions of a building or structure, at a given level, between the outside surfaces of its exterior walls. The “length” of a building or structure is the greatest plan dimension parallel to an exterior wall or walls, and is equivalent to the horizontal dimension of the corresponding elevation of the building or structure at that level. The “diagonal dimension” of a building or structure is the plan dimension between the two most separated points on the exterior walls.

**Principal Facades:**

Exterior walls of a building which are adjacent to or front on a public street, park or plaza.

**Setback:**

The area between the edge of a building and the property line.

**Story:**

That portion of a building, except a mezzanine as defined in the San Francisco Building Code (in effect as of the adoption of this Design for Development), included between the surface of any floor and the surface of the next floor above it, or if there is no floor above it, then the space between the surface of the floor and the ceiling next above it.



---

**Story, Ground:**

The lowest story of a building, other than a basement or cellar as defined in the San Francisco Building Code (in effect as of the adoption of this Design for Development).

**Street:**

A right-of-way permanently dedicated to common and general use by the public, as described in the Plan Area Project Boundary, Development Block and Street Grid Maps.

**Streetwall:**

Continuous facade of buildings generally built along the property line facing a street or open space.

**Structure:**

Anything constructed or erected which requires fixed location on the ground or attachment to something having fixed location on the ground.

**Tower Base:**

Term used within the Height Zone standards to describe the portion of a building below the tower height as defined herein.

**Tower Height:**

That portion of any building, **except for an Event Center**, with height above 90 feet.

**Vara Block:**

San Francisco's historic city block measuring 275 feet (100 Varas) by 412.5 feet (150 Varas). A Vara is an early Spanish unit of measure equal to 2.75 feet. The Vara block is used within Mission Bay as an extension of the City's historic urban fabric.

---

# III . D e s i g n S t a n d a r d s

**Introduction:**

The Design Standards contained in this document are mandatory provisions that will govern the development of the Plan Area unless a variance is obtained. They regulate areas such as land use, height, bulk, setbacks, coverage, streetwalls, view corridors, open areas, parking/loading and access. The Agency may, in its discretion, grant variances to the design standards contained in this Design for Development where the enforcement would otherwise constitute an unreasonable limitation beyond the intent and purpose of the Design for Development and the Redevelopment Plan and is consistent with the public health, safety and welfare.

Design Standards for the Plan Area are described herein. For informational purposes, a Land Use Map is provided on the following page. Land uses are described in the Redevelopment Plan.

Land Use Plan

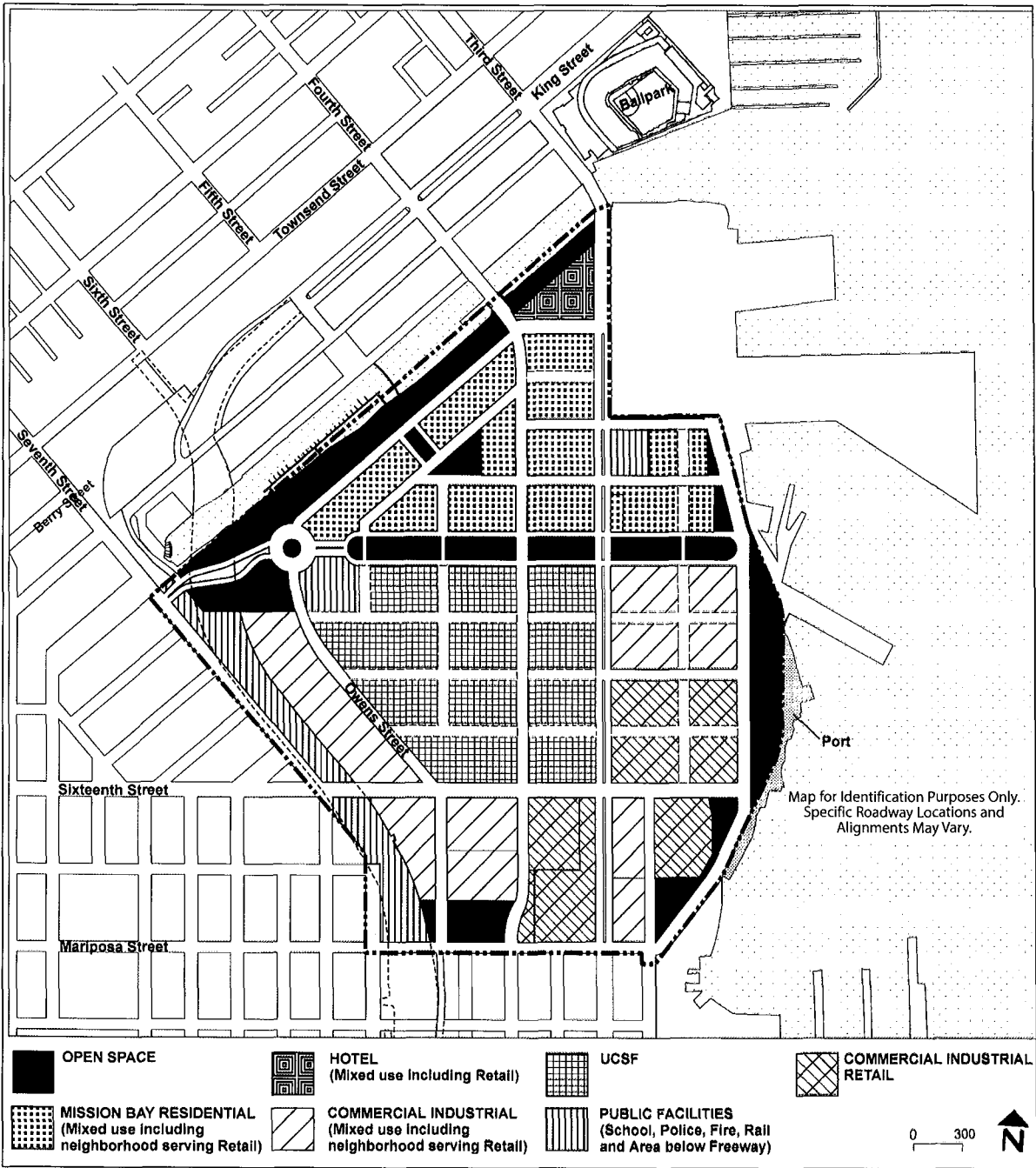

Map 2

## Maximum Development

The maximum development program that has been established for the Plan Area is outlined in the Redevelopment Plan.

Plan Boundary, Development Block and Street Grid Map

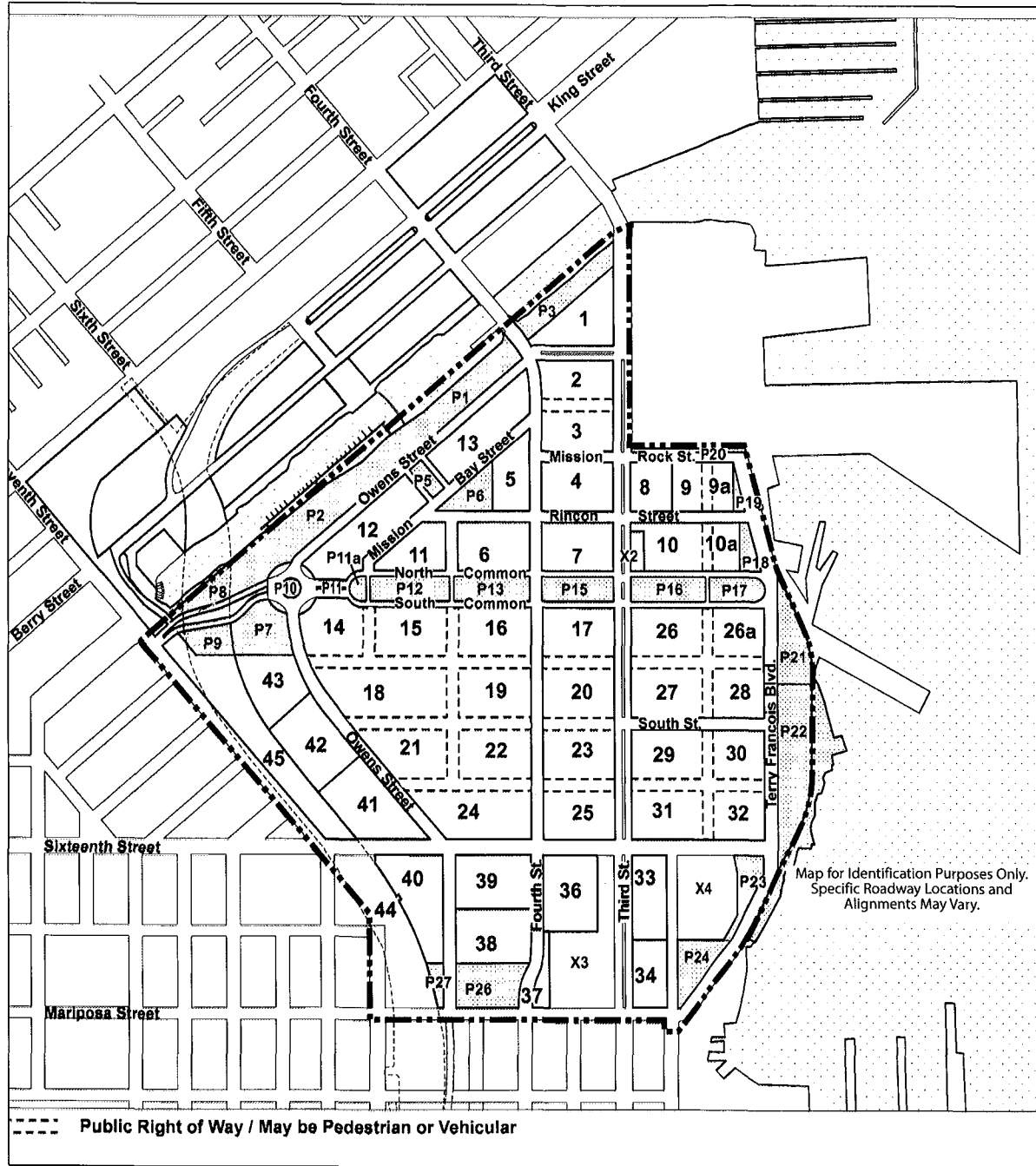

Map 3

# Height

For the purposes of establishing height limits within the Plan Area, Height Zones are established as generally illustrated on the Height Zone Chart and Height Zone Diagram included herein. Refer to Definition of Terms section for “Building Height” and “Developable Area.” The percentage of Developable Area at a specified height is calculated for the entire developable area within a height zone, not on a block by block basis.

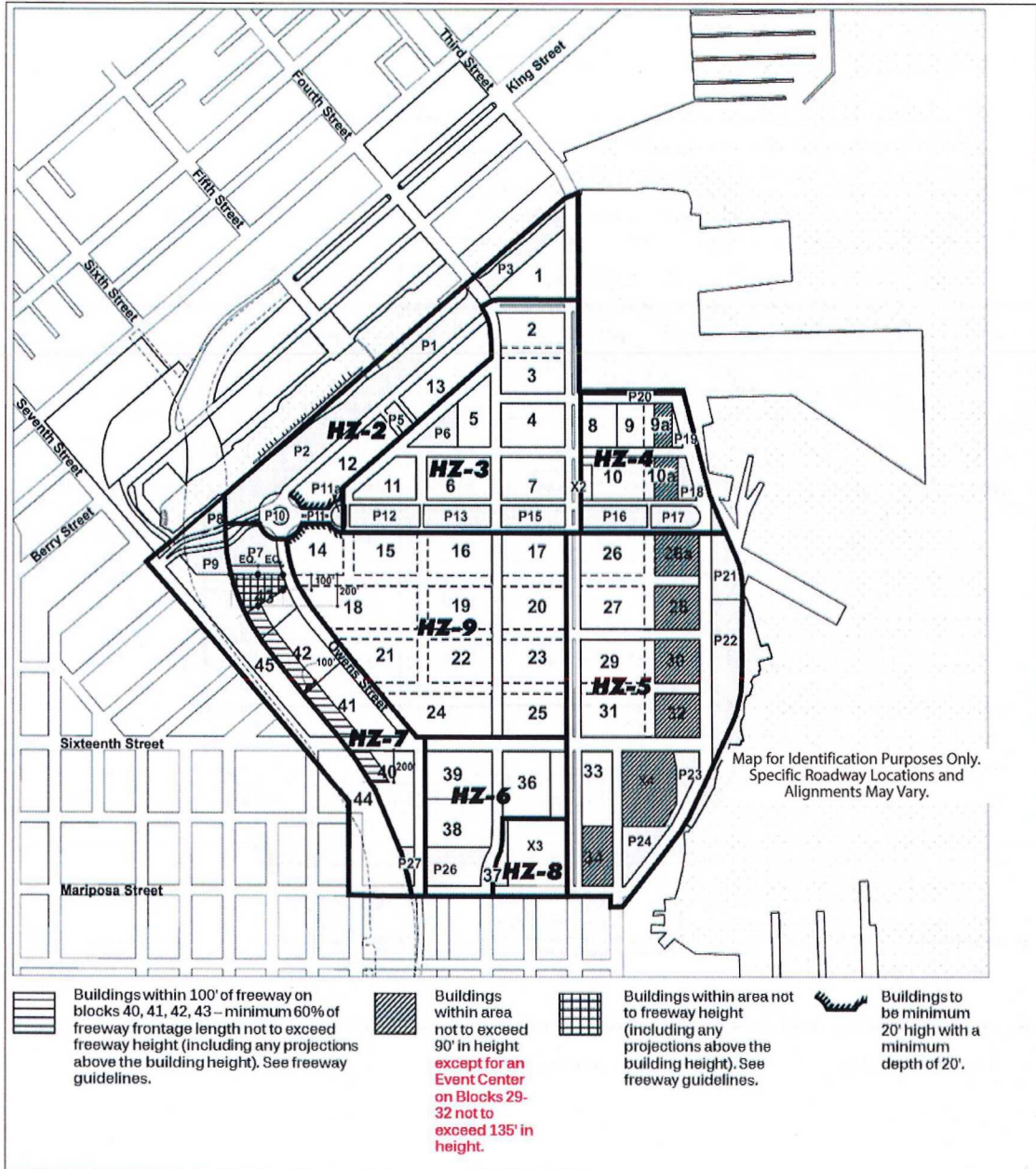

Map 4



### III. DESIGN STANDARDS

	Residential/Hotel			Commercial/Industrial			
	HZ-2	HZ-3	HZ-4	HZ-5	HZ-6	HZ-7	HZ-8
Total Developable Area:	418,180 SF	686,505 SF	221,720 SF	942,200 SF	424,270 SF	551,467 SF	190,964 SF
Base Height	65'	65'	65'	90' (Event Center 135')	90'	90'	90'
% of developable area at base height	75%	80%	80%	<del>93%</del> 90%	90%	85%	89%
Midrise Height	90'	90'	90'	NA	NA	NA	NA
% & sq. ft. of developable area with midrise height max.	10%(41,818 sq. ft. of develop. area)	13% (89,246 sq. ft. of develop. area)	13% (28,824 sq. ft. of develop. area)	NA	NA	NA	NA
Tower Height	160'	160'	160'	160'	160'	160'	160'
% & sq. ft. of developable area with tower height max.	15% (62,726 sq. ft. of develop. area)	7% (48,055 sq. ft. of develop. area)	7% (15,520 sq. ft. of develop. area)	<del>7%</del> (65,954 sq. ft. of develop. area) 10% (94,220 sq. ft. of develop. area)	10%(42,427 sq. ft. of develop. area)	15% (82,720 sq. ft. of develop. area)	11% (21,006 sq. ft. of develop. area)
Maximum number of towers at max. bulk and height	<del>7</del> 6	6	2	<del>3</del> 4, 2 of which must be on Blocks 29 or 31.	2	4	1
Location	NA	NA	No towers on parcels 9a and 10a. Max. 50' average on Bayfront to a depth of 20' on each block.	No towers on parcels 26a,28, 30, 32, 34 & X4		Buildings above height of freeway in limited locations (see map). Tower on parcel 43 limited to SE corner.	NA
Corners	Except for 16th Street and Third Street, no intersection to allow more than 2 towers within 50' of corner.						
Tower Separation	Minimum 125' when located on the same block. Exceptions considered for slim/multiple tower designs with Agency approval, subject to further shadow and visual analysis (see Fig. 6)			Minimum 100' when located on the same block, and a minimum of 40' between a tower and an Event Center.		Min 200' or separated by 16th Street.	NA
Orientation	Tower width along 3rd street not to exceed 160'						
Rooftop Recreation/Community Structures	For the purposes of height measurement, rooftop recreation structures are exempted, provided that the total height measured from the top of roof does not exceed 16' in height, including mechanical appurtenances, and their use is strictly limited to community recreation.			NA			
% of total roof area	Total area of rooftop recreation/community structures is limited to 25% of the roof area.			NA			
Mechanical Equipment	Mechanical equipment and appurtenances necessary to the operation or maintenance of the building or structure itself, including chimneys, ventilators, plumbing vent stacks, cooling towers, water tanks, panels or devices for the collection of solar or wind energy, elevator, stair and mechanical penthouses, skylights, and window-washing equipment, together with visual screening for any such features are exempt from the height restriction. This exemption shall be limited to the top 10' of such features where the height limit is 65' or less, and the top 36' (20' for a mechanical penthouse, 16' for top of a ventilator stack) of such features where the height limit is more than 65'.						

Note:

Method of Measurement: Refer to Definition of Terms section for "Building Height" and "Developable Area" for method of measurement and exemptions from height limits.

These diagrams are intended to illustrate the Base, Midrise, and Tower concepts:

RESIDENTIAL DISTRICTS  
HEIGHT DIAGRAM  
HEIGHT ZONES 2, 3, 4

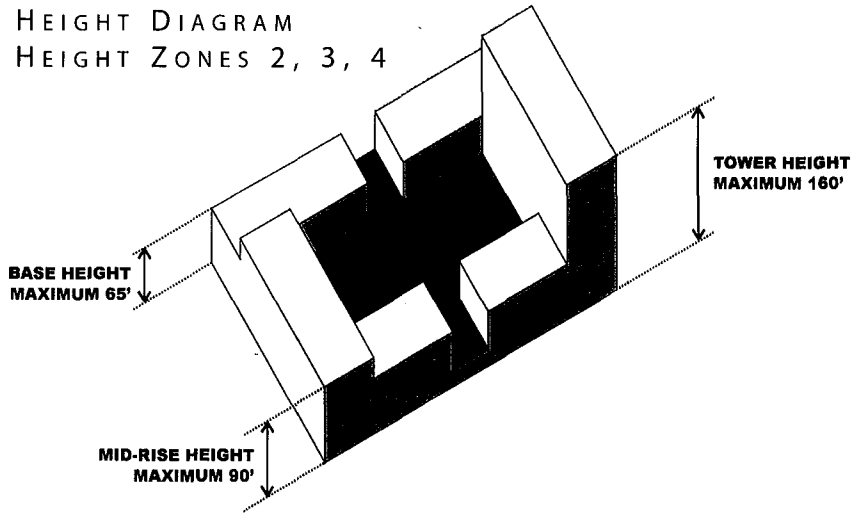

Fig. 1

COMMERCIAL INDUSTRIAL DISTRICTS HEIGHT DIAGRAM  
HEIGHT ZONES 5, 6, 7 & 8

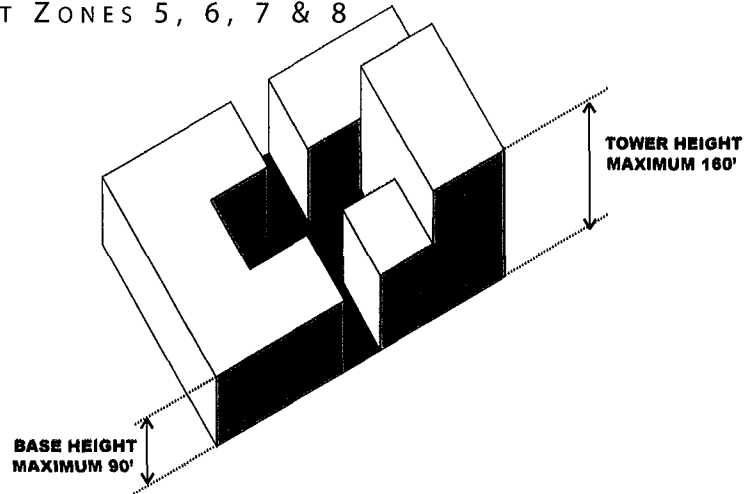

Fig. 2

### III. DESIGN STANDARDS

These diagrams are intended to illustrate the Height Standards.

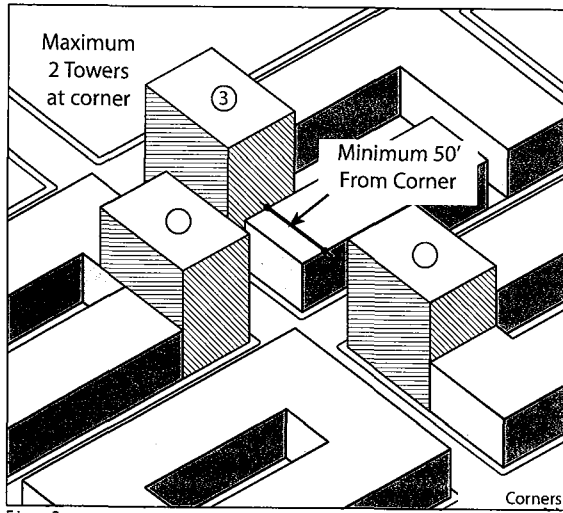

Fig. 3

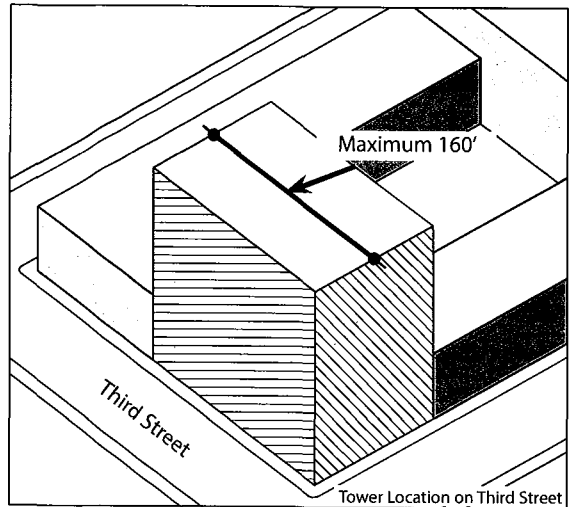

Fig. 4

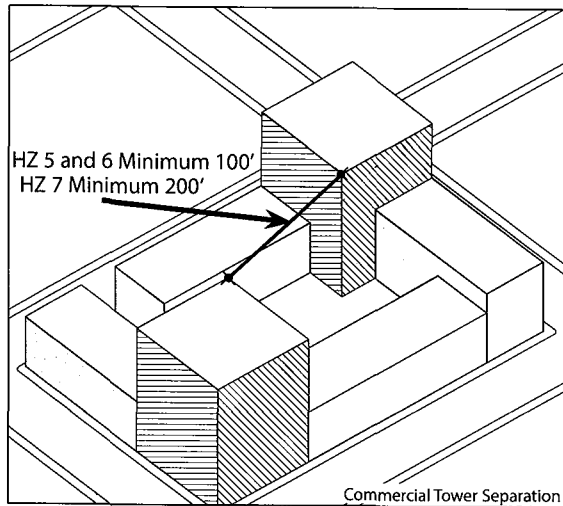

Fig. 5

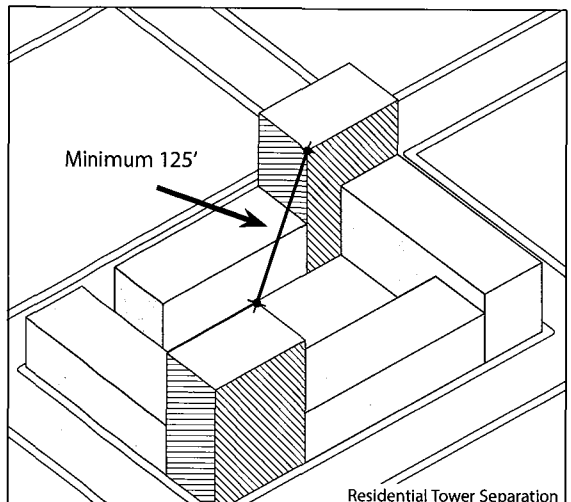

Fig. 6

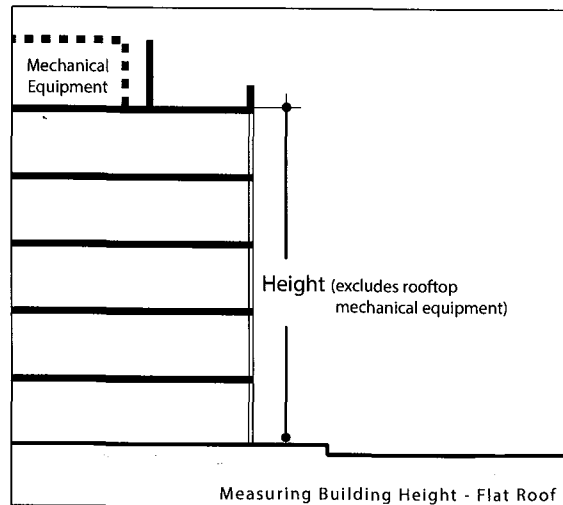

Fig. 7

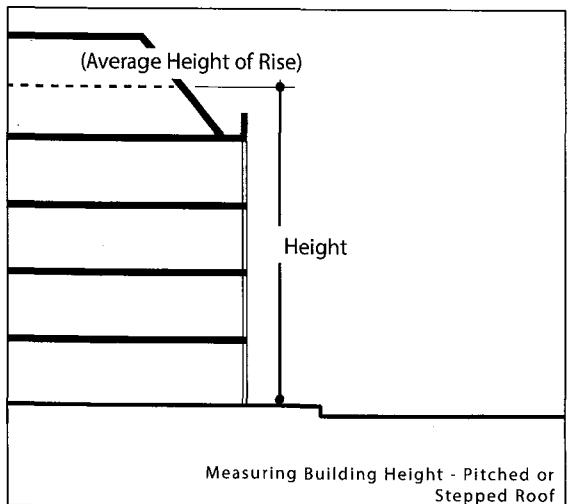

Fig. 8

# Bulk

Bulk standards control the length and width of towers to preserve light and air and prevent construction of massive buildings which block views and generally disrupt the character of the city.

Bulk controls shall apply as follows:

Height Zones	Residential/Hotel			Commercial Industrial			
	HZ-2	HZ-3	HZ-4	HZ-5	HZ-6	HZ-7	HZ-8
Bulk (above 90')	Max. residential plan diagonal 190' Max. residential plan length 160' Max res. floor plate 17,000 sq. ft. Max. hotel plan length 200' Max. hotel floor plate, 20,000 sq. ft.			Max. plan length 200' Max. floor plate 20,000 sq. ft. For an Event Center: Max. diagonal plan dimension 600'			

These diagrams are intended to illustrate the bulk concepts:

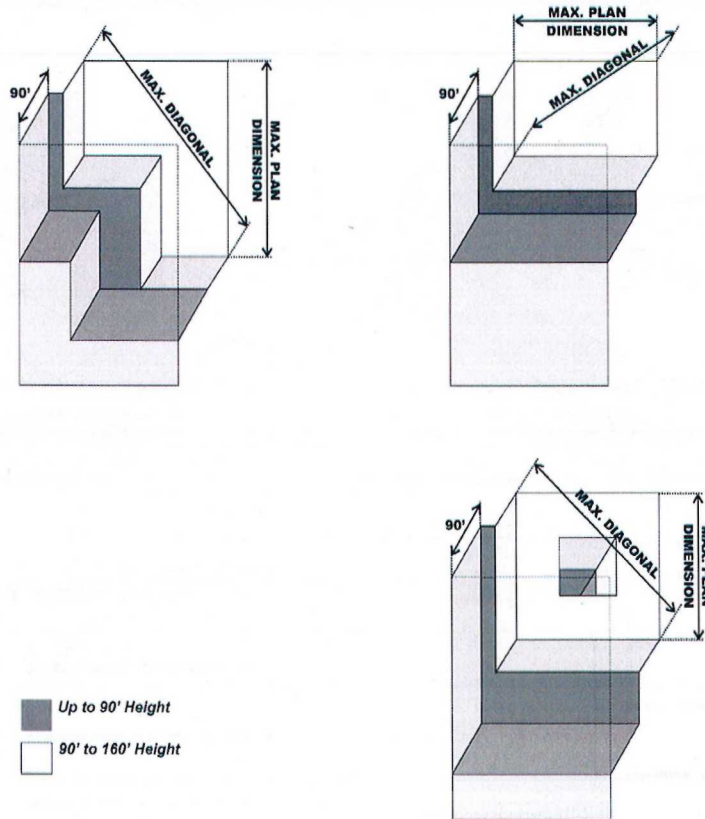

Fig. 9 Bulk



Setbacks

Setbacks are required to provide space for certain pedestrian and bike path links and for connection of major open spaces. Setbacks shall be generally as indicated in the Setbacks Diagram and Setbacks Chart included herein. These setbacks are in addition to specified sidewalk widths on these streets and may be used for paved pathways and landscaping as appropriate.

	Residential/Hotel	Commercial Industrial
<b>Setbacks</b>		
<b>Required Setbacks</b>	5' setback on west side of Third Street from one block south of the Channel to Mariposa Street. 5' setback on east side from Mission Rock to Mariposa Street.	
	NA	20' setback on north side of 16th Street from Terry Francois to Owens.  20' setback on east side of Owens from 16th to the Commons. 20' setback on north side of Mariposa from Terry Francois to Owens Street.  <b>The Event Center shall be permitted to encroach within the required setback on the north side of 16th Street between Terry Francois Boulevard and Third Street as long as a minimum average of 20' is provided along that frontage.</b>

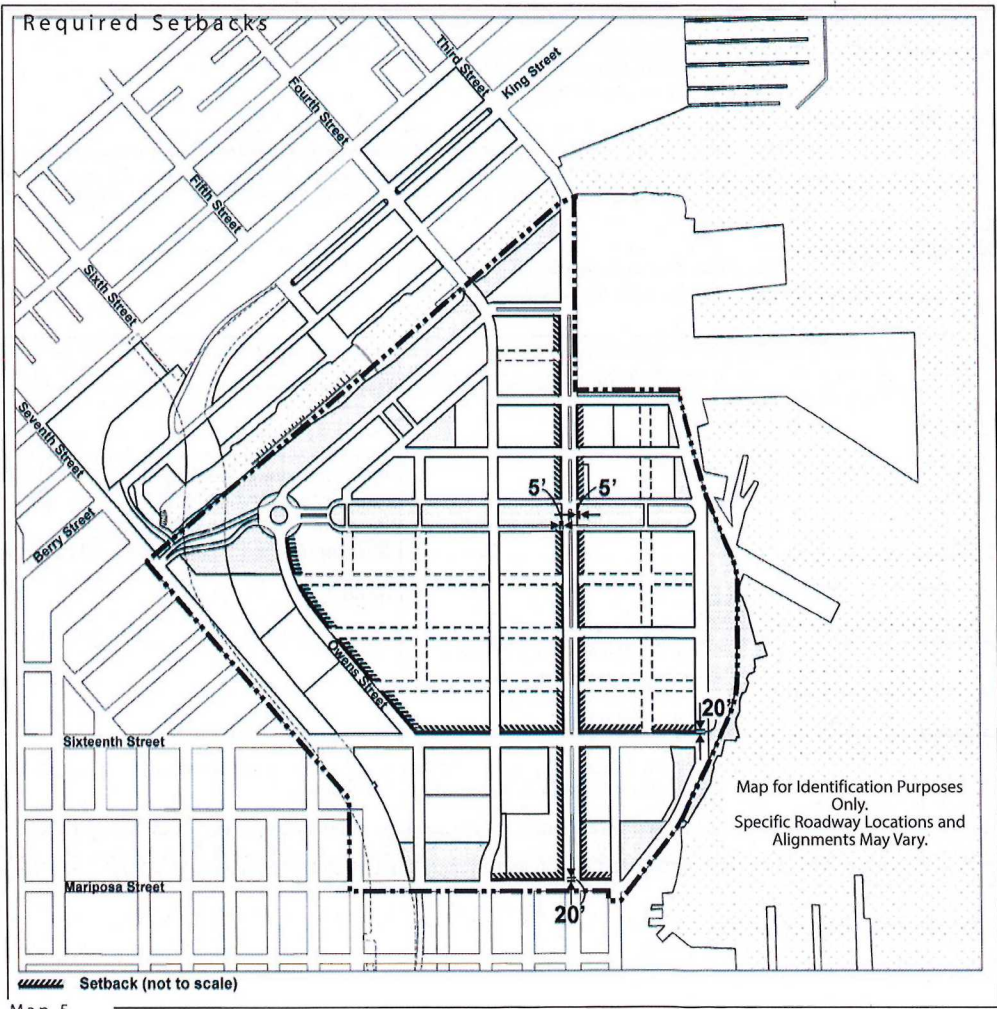

Streetwall and lot coverage standards are required as follows to maintain the consistent building to street relationship that is common throughout San Francisco:

	Residential/Hotel	Commercial Industrial
<b>Lot Coverage</b>		
Maximum Lot Coverage	100% lot coverage to a maximum height of 40'. For buildings above 40' in height, a maximum of 75% lot coverage is allowed for those portions of the building above 40' (See Fig. 10). Parking structures serving residential uses, and not exceeding a maximum height of 65' shall be allowed 100% of lot coverage.	NA
<b>Streetwall</b>		
Minimum Length	Minimum 70% of block length frontage required for streetwalls along primary streets including 3rd, 4th, 16th, Commons, and Owens (See Map 6, Fig. 11). 70% refers to a total measurement from street to street with no exceptions for pedestrian pathways, <b>except for 3rd and 16th frontages surrounding an Event Center</b> . On development on Blocks fronting the rotary at the intersection of the Commons and Owens St., 100% streetwall is required.	
Minimum Height	15 feet	
Maximum Height	Height not to exceed 65' (except for mid-rise and towers). Average streetwall height along a block not to exceed 55' to a depth of 20' on designated neighborhood streets (See Map 7: Neighborhood Streets).	Height not to exceed 90' (except for mid-rise, <b>Event Center</b> , and towers).
Corner Zone Conditions	At all intersections along primary streets, (as identified on Map 4: Primary Streets) build to streetwall at all corners for a distance of 50' (See Fig. 14). Height of building at corner to be no less than 15 feet. Corner <b>and Event Center</b> entries are exempted. On blocks 12 & 14, development fronting the rotary, height of buildings to be no less than 2 stories.	
Streetwall Variation	10' variation within the streetwall frontage is allowed. Additional variations may be permitted subject to design review (See Fig. 12).	NA
Required Step-backs	Buildings in HZ-2 and HZ-3 along P5 and P6 are required to use a stepback of 20' from the property line at or below 65' in height.	Buildings in HZ-5 along the Commons are required to use a stepback of 30' from the property line at the 55' height, and 110' feet from the property line at 90' height (See Fig.15). Buildings on parcel X4 are required to use a stepback of 60' from the property line at 55' at P23 (Bayfront Park); and a stepback of 30' from the property line at 55' at P24 (Mariposa Bayfront Park). Buildings on parcel X3 are required to use a stepback of 50' from the property line on Mariposa Street at 90' height.
Pedestrian Walkway	A minimum of one north-south exclusively pedestrian public walkway 30' wide and open to the sky required on each of Blocks 12 & 13. Pedestrian walkways shall be publicly accessible during daylight hours.	NA
Projections	Architectural projections over a street, alley, park, or plaza shall provide a minimum of 8 feet of vertical clearance from the sidewalk or other surface above which it is situated. Projections include: <ul style="list-style-type: none"> <li>• Projections of purely architectural or decorative character such as cornices, eaves, sills, and belt courses, with a vertical dimension of no more than two feet six inches, not increasing the floor area of the volume of space enclosed by the building, and not projecting more than three feet over streets, alleys, and public open spaces.</li> <li>• Bay windows, balconies, and similar features with a maximum projection of three feet over streets and public open spaces.</li> </ul>	



Primary Streets for Streetwalls

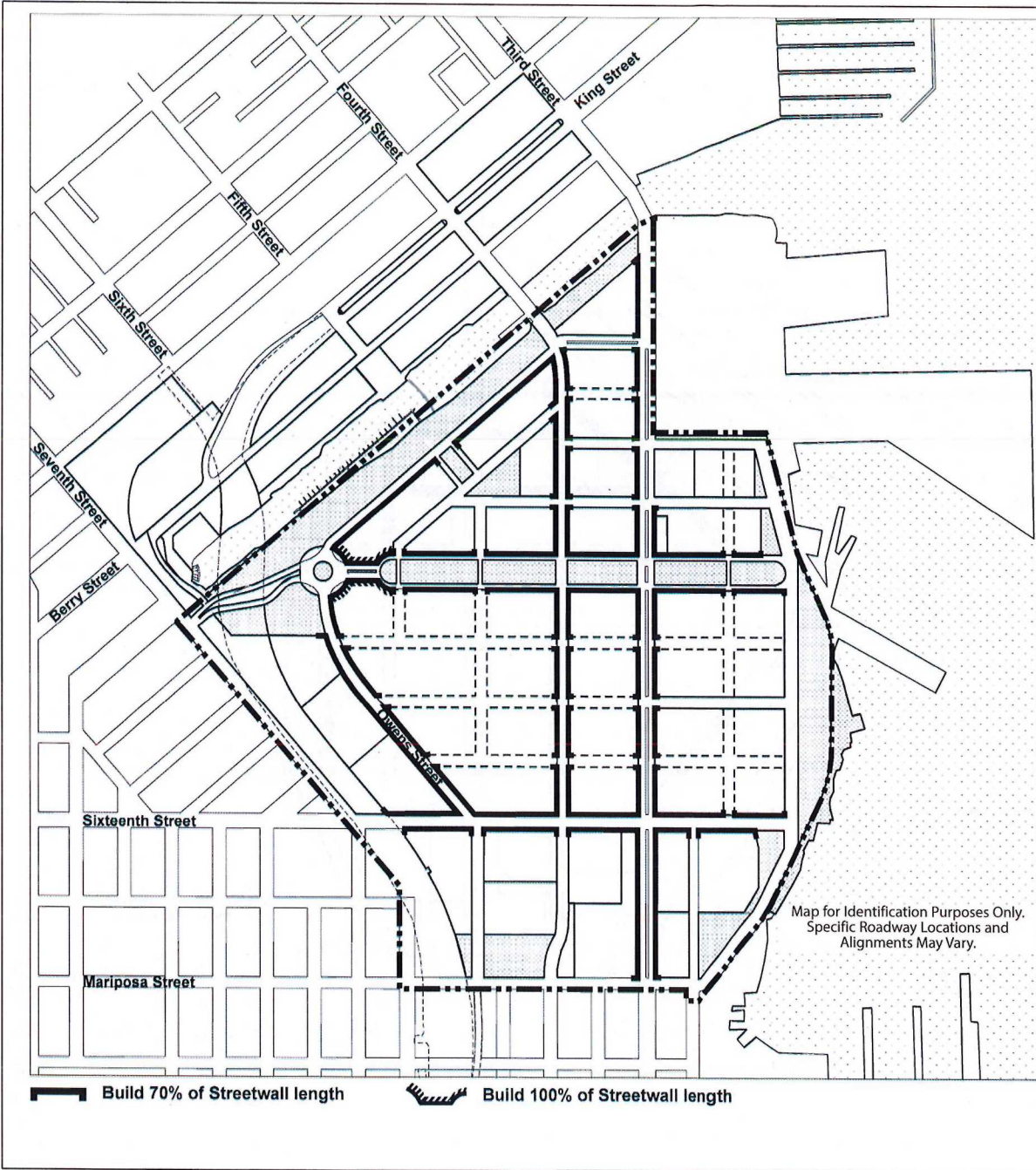

Map 6



Neighborhood Streets  
for 55' Average Height

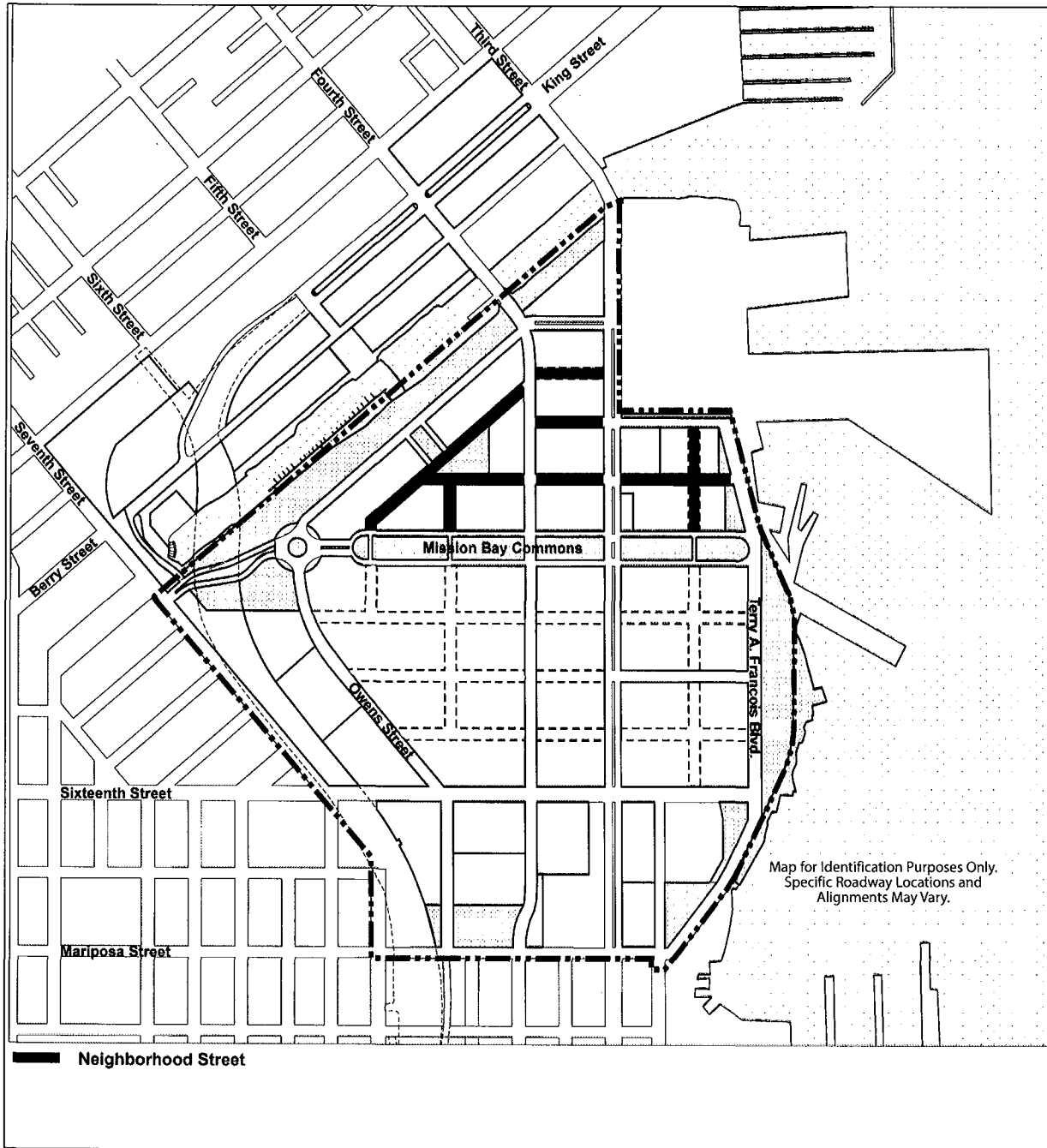

Map 7

These diagrams are intended to illustrate the coverage and streetwall concepts:

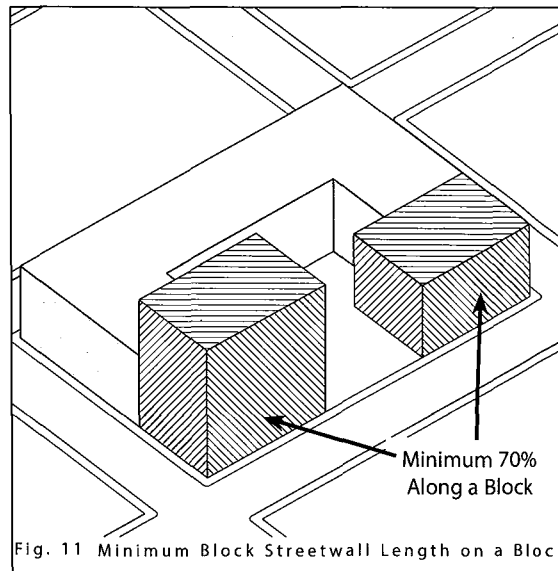
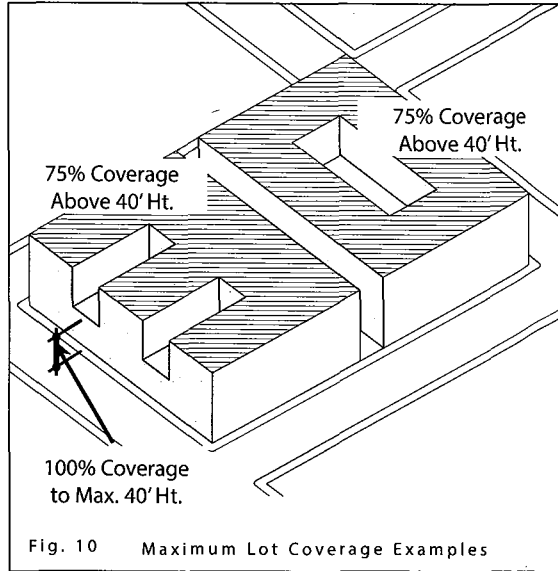

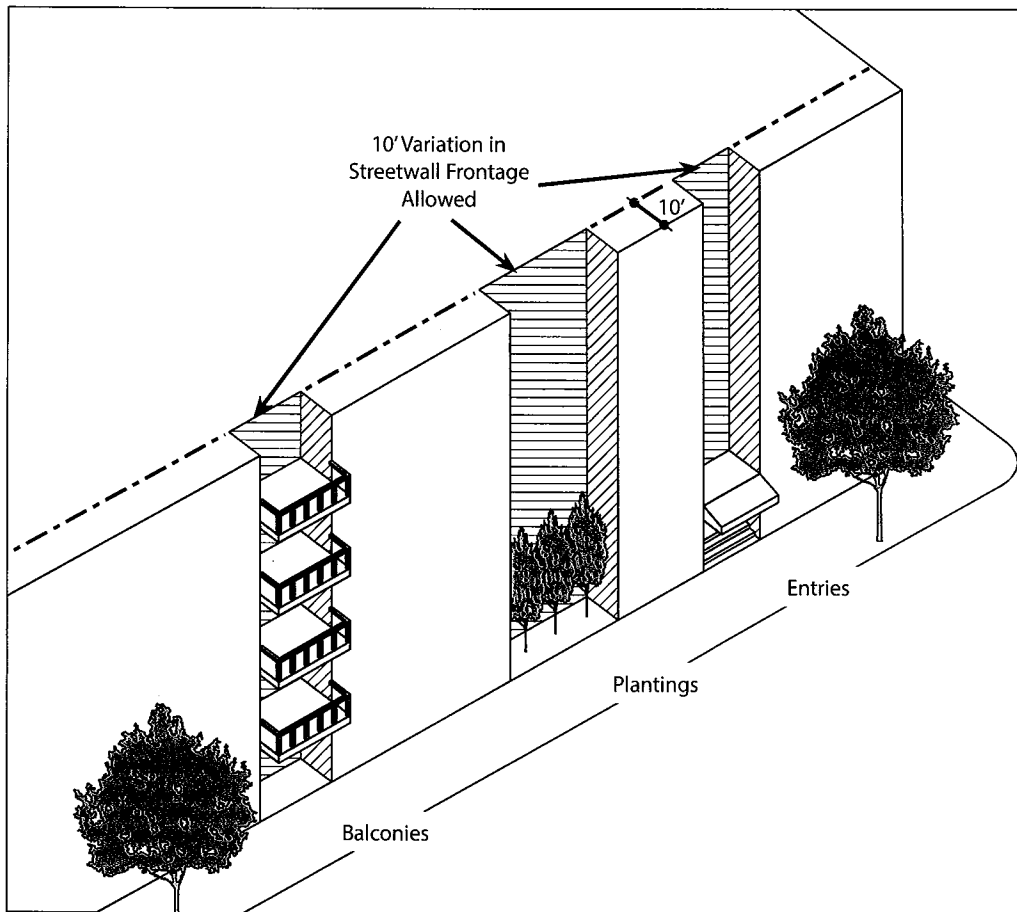

Fig. 12 Streetwall Variation Examples

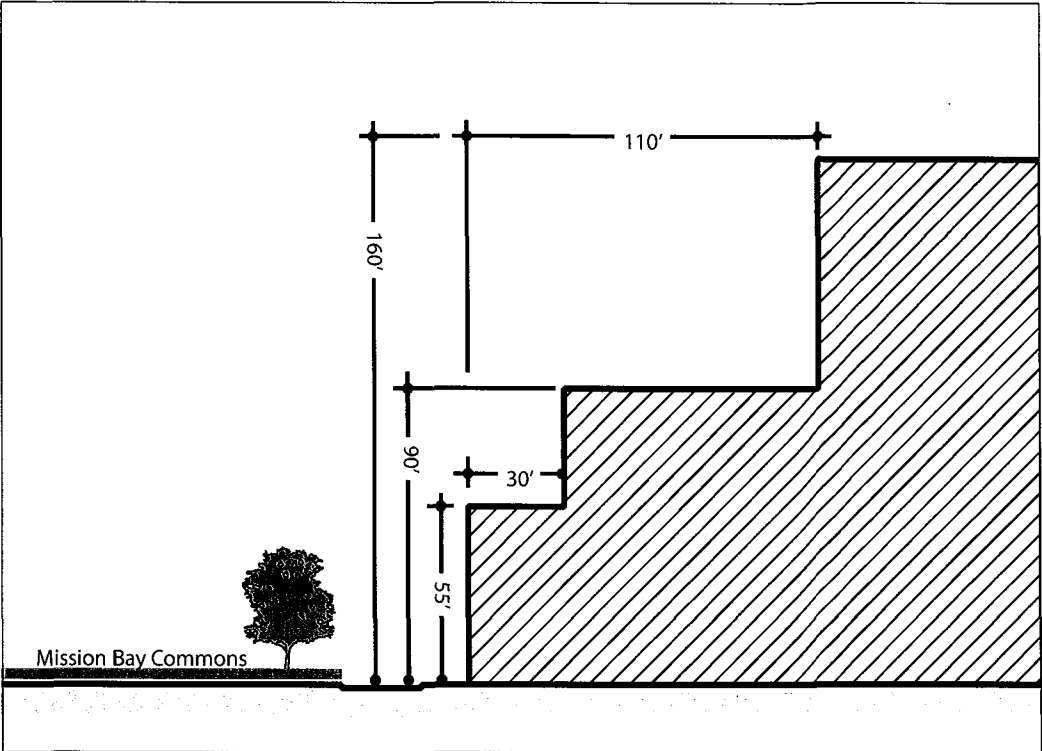

Fig. 13 Required Setbacks in HZ5 for Blocks 26 & 26A

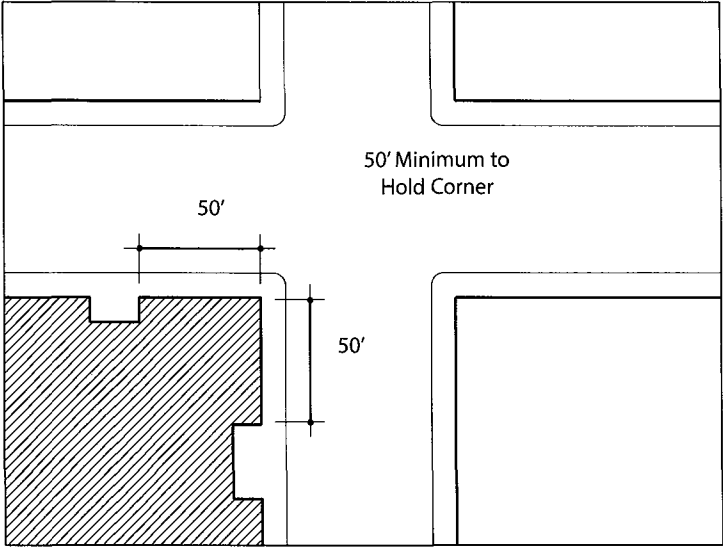

Fig. 14 Corner Zone Conditions

---

## Open Space (Public)

At full buildout, the Plan Area shall include approximately 41 acres of publicly accessible open space, including a minimum of 8 acres of publicly accessible open space within the UCSF campus (see Map 8). Connectors and setbacks, while they will be publicly accessible, are not included in the 41 acres of public open space noted above.

## Open Space (Private)

Private open space shall be provided for each dwelling unit in the amount of 70 square feet.

Private residential open space may consist of open space for an individual unit or common usable open space shared by all residents. The requirements can be satisfied in a number of ways and in a variety of areas such as:

- Individual unit open space: patios, terraces, or balconies adjacent to the unit. For individual unit open space to be counted towards the private open space requirement, the minimum horizontal dimension shall be 6 feet.
- Common open space: mid-block lanes (provide they do not permit through traffic other than emergency vehicles), gardens, building courtyards at grade level, rooftop and parking podium level gardens, decks, solaria, and atria open to sun and air, open terraces or recreational facilities for use by residents.
- Sufficient soil depth shall be provided to ensure adequate growth and health for planting within open space on roof decks. The minimum size of trees at installation should be 24" box, and irrigation and under-drainage should be provided for all planting.

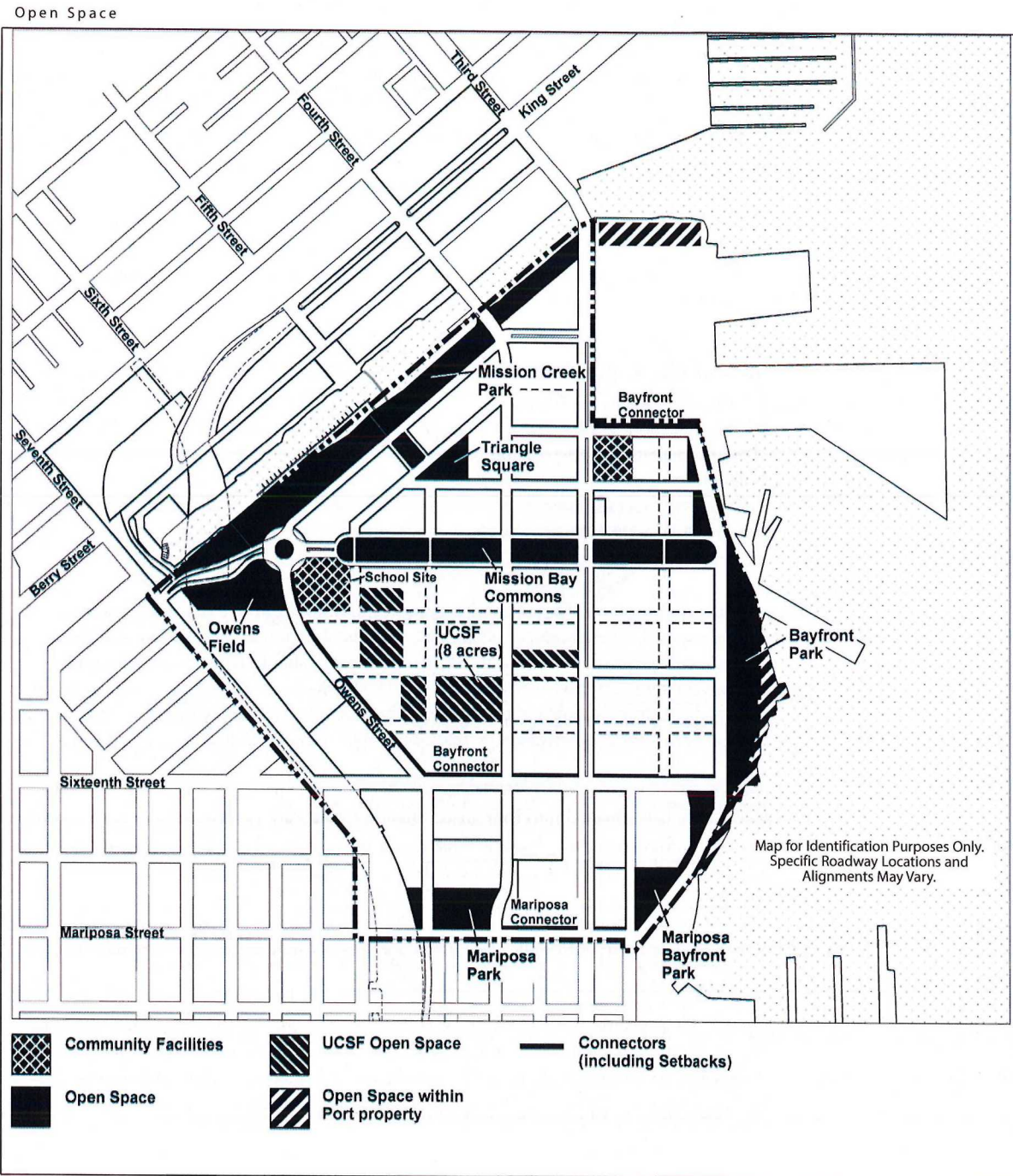

Map for Identification Purposes Only.  
Specific Roadway Locations and  
Alignments May Vary.

---

## Sunlight Access to Open Space

Design Standards outlined in this document have been prepared with the objective of encouraging new developments to ensure sunlight access to public open spaces and limit the area and duration under shadow. Shadow studies have determined that development complying with the Design Standards will reasonably limit areas of shadow on public open spaces during the active months of the year and during the most active times of the day.

Additional shadow analysis will not be required unless, as a part of a specific project application, the project applicant seeks a variance from the Design Standards herein that establish the shape and location of buildings. Standards determining the shape and location of buildings include:

1. Height
  - Base, Midrise, & Tower Heights
  - Maximum Number of Towers
  - Height Location
  - Tower Orientation, & Separation
2. Bulk
3. Coverage & Streetwall
  - Streetwall Heights
  - Required Stepbacks

If a project applicant requests approval for an exception to the above standards shadow analysis is required. The amount of area shadowed, the duration of the shadow, and the importance of sunlight to the use patterns of open spaces should be taken into account when determining the impact of shadows from development. A project for which an exception is sought shall not create additional areas of public open space in continuous shadow for periods of one hour, as determined by shadow analysis using the following methodology:

1. For the purposes of assessing the impact of shadows on Mission Bay open spaces, open spaces have been divided into four areas: Mission Creek Park (which includes both North and South), Bayfront Park, Triangle Square, and the section of Mission Bay Commons, between Third Street and Terry Francois Boulevard (see Map 9 on page 37)
2. Shadow analysis should study the area of public open space in continuous shadow for periods of one hour, during the most active months of the year (March-September) and during the most active times of the day (10am-4pm).
3. Analysis for a specific development proposal should take into account aggregate shadow impacts from all buildings over 40 feet in height adjacent to the public open space. For the purpose of shadow analysis, undeveloped parcels should be analyzed using either approved plans for future development or a plan that resembles the maximum allowable building envelope for that parcel.

### III. DESIGN STANDARDS

4. The total area of each of the described public open spaces should be the basis for shadow calculation. To reasonably limit areas of open space in continuous shadow for extended periods of time, the area of public open space in continuous shadow for a period of one hour from March to September between 10am and 4pm should not exceed the following percentages:

Mission Creek Park		13%
Bayfront Park	20%	
Triangle Square		17%
Mission Bay Commons		11%

Shadow Analysis:  
Open Space

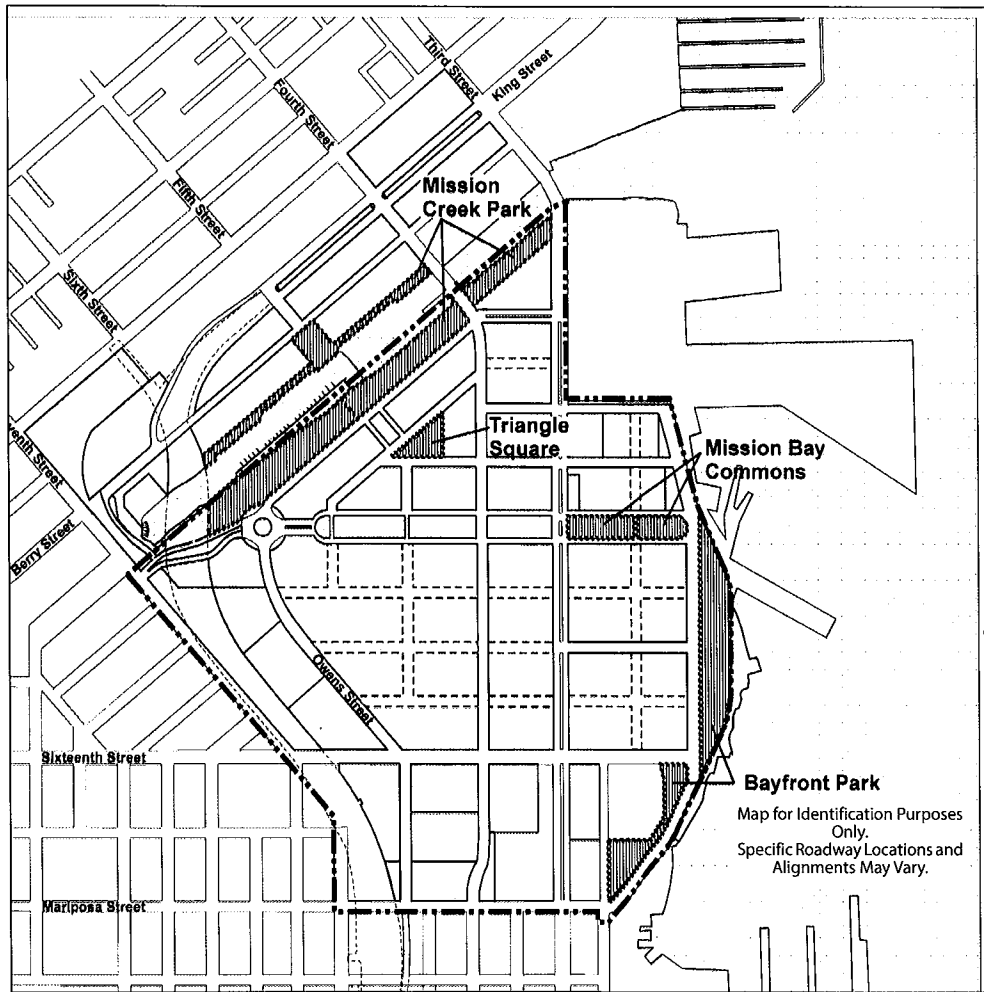



---

## Wind Analysis

### Standard:

Wind review will be required for all projects that include buildings over 100 feet in height. Wind tunnel testing may also be required for these buildings unless, upon review by a qualified wind consultant, and with concurrence by the Agency, it is determined that the exposure, massing, and orientation of the building are such that adverse wind impacts will not occur. Wind analysis shall be conducted to assess wind conditions for the project in conjunction with the anticipated pattern of development on surrounding blocks. The objective shall be to use all feasible means to eliminate wind hazards and to reduce adverse wind impacts, including uncomfortable wind conditions, if predicted.

### Guidelines:

For blocks that are exposed to winds from the west or north-west, particularly if they front open space, attention should be paid to wind-conscious design. The following guidelines are examples of methods that can be used to eliminate wind hazards and/or to address adverse wind impacts:

- Western facades can be modulated through the use of architectural devices such as surface articulation, variation of planes, wall surfaces, and heights, as well as the placement of stepbacks, courtyards, plazas, and other features.
- Landscaping in appropriate locations, can be used to mitigate wind. Porous materials (vegetation, hedges, screens, latticework, perforated or expanded metal) offer superior wind shelter as compared to a solid surface. Such wind sheltering elements should be located west of the area being protected, and should be of sufficient height. Wind shadows behind porous wind screens provide shelter for a distance downwind equivalent to 3-5 times the height of the wind screen.
- “Breezeways” or notches at the upwind corners of the building should be avoided.
- Building stepbacks can be used to ameliorate ground level wind accelerations. If these stepback areas are used as terraces, they are likely to need properly designed wind screening elements or even partial enclosure to ensure usability. Any wind sheltering strategy should address the likely significant downward component of these winds, particularly below west facing building elements

#### View Corridors

View corridors follow street alignments and are defined by the Mission Bay South Project Boundary, Development Block and Street Grid Map 3 on page 21.

View corridors are based on the following principles: to preserve the orientation and visual linkages to the Bay and Channel; as well as vistas to hills, the Bay Bridge and the downtown skyline; to preserve orientation and visual linkages that provide a sense of place within Mission Bay.

- No building or portion thereof shall block a view corridor, **provided, however, that a view corridor on Blocks 29-32 may terminate in an Event Center that provides an important architectural statement as recommended in the Commercial Industrial Guidelines.**
- The street grid is an extension of San Francisco's historic urban pattern of Spanish measure Vara blocks.

## Street System

The Mission Bay South Street Grid system shall be generally as described and illustrated in the Mission Bay Street Grid Diagram provided herein.

Street	Description
<b>Arterial Streets</b>	
Third Street	Existing arterial connecting to the South of Market and Bayview Districts. Bus and Light Rail.
Sixteenth Street	Major east-west arterial. Main link to Potrero Hill under I-280.
<b>Minor Arterial Streets</b>	
Mariposa Street	Minor arterial linking Potrero Hill to the Bayfront and providing Freeway access.
Owens Street	Minor north-south arterial. UCSF campus service street. Link to I-280 exit south of Mariposa.
Seventh Street (& Seventh Street Connection)	Minor arterial linking Mission Bay to South of Market and downtown.
Terry Francois Boulevard	Bayfront scenic boulevard providing access to water-edge uses, Bayfront Open Space, and the Bay Trail.
<b>Collector Streets</b>	
Fourth Street	Local collector and bicycle commute street that serves as a connector to the South of Market District, UCSF, and the core of the Mission Bay South Neighborhood Commercial District
Illinois Street	Local collector south from Sixteenth Street.
South Street	Local collector south from Third Street to Terry Francois Boulevard.
<b>Neighborhood Streets</b>	
Fifth Street	Minor residential/neighborhood street with open space and segments for pedestrian use.
Mission Bay Commons	Couplet of neighborhood streets running east-west along the Mission Bay Commons from Owens Street to Terry Francois Boulevard.
Residential Streets	Minor streets in the residential district designed to be pedestrian-friendly and discourage through traffic.

Street Hierarchy

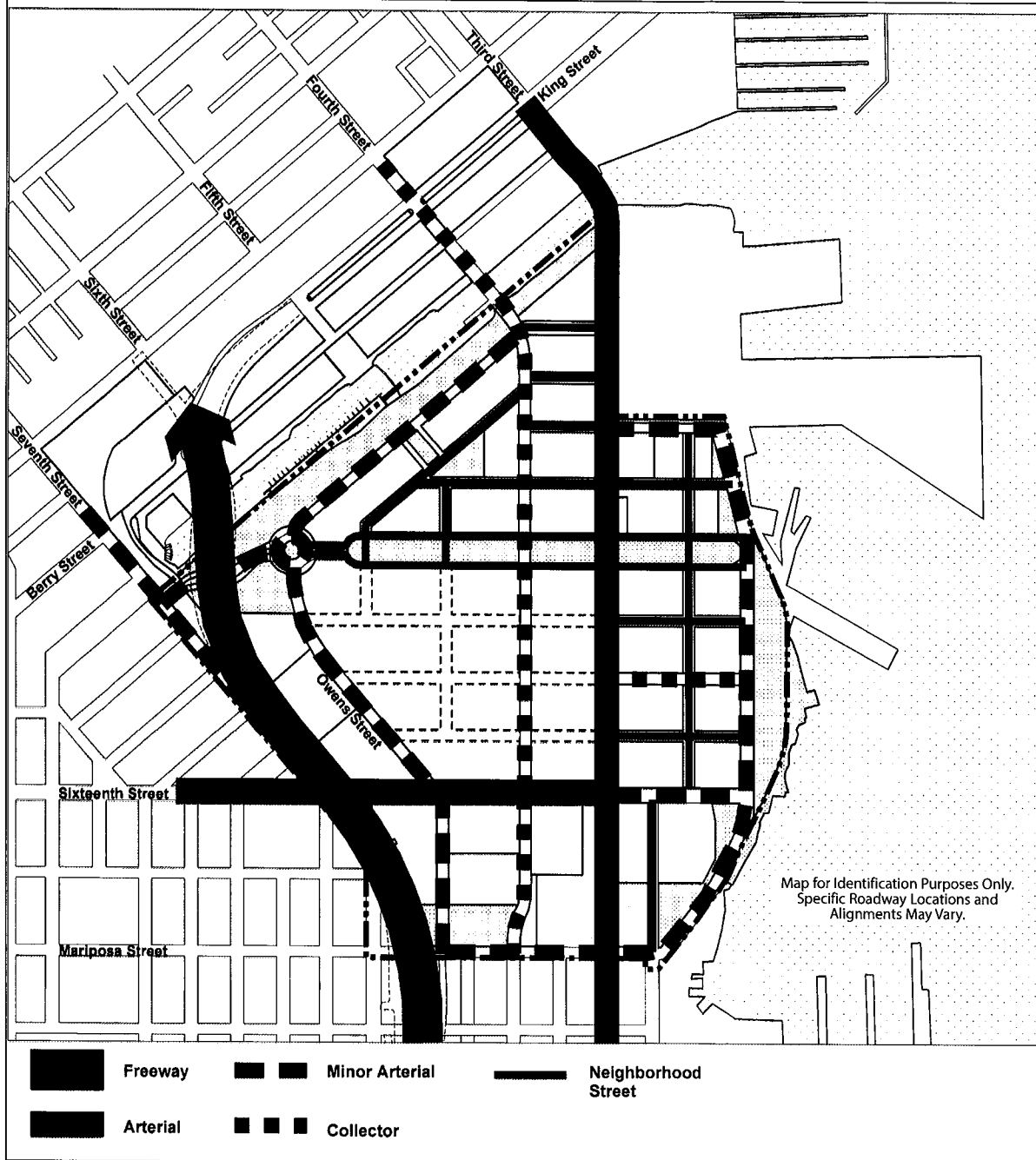

Map 10

---

## P a r k i n g

The number of off-street parking spaces required and/or allowed for uses within Mission Bay South shall be as prescribed in the table included herein. Parking calculations shall be based on the total aggregate anticipated square footage by structure (and in the case of the Event Center, total number of seats) rather than applied to any single tenant. When the calculation of off-street parking spaces results in a fractional number, it must be adjusted to the closest whole number of spaces.

- Parking for residential and retail uses shall be screened from view of pedestrians. (See guidelines for recommended methods).
- One secure bicycle parking space must be provided for every 20 vehicular parking spaces or fraction thereof.
- The entrance to any offsite parking facility shall not be more than 600' from the entrance to the building in which units are located. The existence of offsite parking facilities may be used to satisfy some portion of the parking requirements for a project on Blocks 29-32 that is approved to include an Event Center, provided that the entrance to any such offsite parking facility is located within 300' of an Event Center Project building entrance.
- Parking spaces provided for a project on Blocks 29-32 that is approved to include an Event Center may be shared among various users of Blocks 29-32 as determined by such users (for example, without limitation, parking spaces provided for daytime office use may be used by the Event Center on nights and weekends).
- Rooftop parking in residential and mixed-use areas shall be screened from views of above utilizing such methods as landscaping, trellises or structures.
- The required ratio of compact spaces to standard size spaces is 50%.
- The minimum size requirement for parking spaces is: compact = 127.5 s.f.; standard = 160s.f.

### III. DESIGN STANDARDS

Use	Number of Parking Spaces
Residential	Maximum of one space for each dwelling unit
Retail (Excepting specific uses addressed below)	<p>Maximum of one space for each 500 square feet of gross floor area up to 20,000 square feet, plus one space for each 250 square feet in excess of 20,000 square feet.</p> <p>For retail greater than 20,000 square feet, the minimum amount of parking required is 75% of the maximum number of parking spaces allowed.</p> <p>For retail greater than 50,000 gross square feet, a ratio could be established by the Redevelopment Agency based on development specific parking demand and not to exceed 10% greater than the limit stated herein.</p>
Restaurants, bars, clubs, pool hall, dance hall, or similar enterprise.	<p>Maximum of one space for each 200 square feet of gross floor area, where the occupied floor area exceeds 5,000 square feet.</p> <p>For these uses greater than 20,000 square feet, the minimum amount of parking required is 75% of the maximum number of parking spaces allowed.</p>
Commercial Industrial	One space for each 1,000 square feet of gross floor area shall be provided (maximum and minimum); except that two spaces for each 1,000 square feet of gross floor area shall be permitted for up to 1,734,000 feet of gross floor area of life sciences, biotechnology, biomedical, or similar research facility uses.*
Commercial Industrial Retail	Commercial Industrial uses subject to Commercial Industrial standards. Retail subject to applicable Retail standards.
Theater	Maximum of one space for each eight seats up to 1,000 seats where the number of seats exceeds 50 seats, plus one for each 10 seats in excess of 1,000 seats. The minimum amount of parking required is 75% of the maximum number of parking spaces allowed.
Hotel	Maximum of one space per 16 guest bedrooms.
<b>Event Center</b>	<b>1 space per 50 seats</b>

\* For purposes of this parking provision only, "life sciences, biotechnology, biomedical or similar research facility uses" shall refer to any structure occupied primarily for such use or uses, provided, however, that any structure occupied primarily for administrative functions shall be subject to the one space per 1,000 square feet of floor area standard.

## Loading

Off-street loading spaces shall be provided per gross square feet of floor area as indicated in the following chart. Service and loading docks shall be screened from streets and adjacent uses. For multi-parcel developments, loading spaces can be aggregated. A lower ratio may be established by the Redevelopment Agency based on a development-specific loading study.

- The dimensions of loading spaces shall be at least 10' wide by 35' long by 14' high.
- Loading areas and all refuse storage and dumpsters shall be enclosed within structures and out of view from pedestrians areas.

Use	Spaces	Gross Floor Area
Commercial	0	0 to 100,000
	1	100,001 to 200,000
	2	200,001 to 500,000
	3	Over 500,000 plus 1 for each additional 400,000
Retail*	0	0 to 10,000
	1	10,001 to 60,000
	2	60,001 to 100,000
	3	Over 100,000 plus 1 for each additional 80,000
Residential	0	0 to 100,000
	1	100,001 to 200,000
	2	200,001 to 500,000
	3	Over 500,000 plus 1 for each additional 400,000

Off-street tour bus loading for the Hotel shall be provided as follows:

Number of Hotel Rooms	Number of Loading Spaces
0 -200	0
201 - 350	1
351-500	2

The dimensions of each space shall be a minimum of 45 feet by 9 feet with a minimum clearance of 14 feet. Spaces for tour bus loading can be provided at adjacent curbs or immediate vicinity provided that they do not cause substantial adverse effects on pedestrian circulation, transit operations, or general traffic circulation.



## Signage

The following are general signage standards that apply to all development within the Plan Area. The Agency may require the submission of a uniform signage program in connection with an owner participation agreement. Signage will be reviewed by the Agency as part of the design review process.

- No billboards are permitted.
- No general advertising signs are permitted in the public right-of-way except as integrated in MUNI or DPW street furnishings.

Residential Land Use District:

- Flashing signs, moving signs and roof signs are not permitted.
- Business signs are allowed for retail uses.
- No business signs are permitted above 1/2 of the base height of the building.

Hotel Land Use District (Block 1):

- The hotel parcel is a triangle bounded by the Channel, Third Street and a new street linking Third Street to Fourth Street. Flashing signs, moving signs, and roof signs should not be directed towards the channel edge or the new street at the southern edge of the block.

Commercial Industrial and Commercial Industrial/Retail Land Use Districts:

- Flashing signs, moving signs and roof signs are not permitted.
- Business signs are allowed.
- No business signs are permitted above 1/2 of the base height of the building, except in the following cases:
  - For signs placed along the western facade of buildings located west of Owens Street:
    - Signs may be placed up to a maximum of 80 feet in height of the building;
    - Signs are limited to 200 square feet in size per parcel; and
    - Signs placed above 1/2 of the base height of the building must be lowered to no more than 1/2 of the base height of the building within one year of the I-280 free-way being removed from its current location.
- The Agency will require the submission of a comprehensive signage program for an Event Center Project for Agency discretionary approval, through an amendment to the Mission Bay South Signage Master Plan, which may include flashing signs, moving signs, and roof signs, and business signs above 1/2 of the base height of the building.



# I V . D e s i g n G u i d e l i n e s

Introduction

The Design Guidelines contained in this document provide design recommendations for both private and public design and construction consistent with the Redevelopment Plan.

A few key urban design concepts work together to provide a framework for all elements of future design and construction in the Plan Area. These concepts are reflected to the extent feasible in this Design for Development. First is an urban street grid which builds off of the primary existing streets and a traditional San Francisco pattern of Vara blocks, to allow for the transformation of an industrial pattern to one which welcomes the buildings and open spaces of a living/working/shopping neighborhood. In the tradition of cities by the water, this same framework of streets serves as view corridors that visually connect Mission Bay to the Bay and the City's downtown. A network of varied open spaces located to take advantage of the area's distinctive natural features, sized to serve area needs, and linked visually and physically to invite intensive use is a third key urban design feature. Finally, the concept of interesting, urban scale buildings which establish a clear and consistent building edge along primary streets in both residential and commercial areas will complete a flexible urban design framework within which incremental development can occur to create a new City district.

Taken together, and as illustrated on the attached Urban Design Framework diagram, the pattern of streets, open space and buildings will bring an awareness of the Channel and the Bay front into all subdistricts of Mission Bay. It will open vistas to the City and region -- the downtown skyline, Twin Peaks, Buena Vista Park, Potrero Hill, the Embarcadero and the East Bay. And, it will showcase Mission Bay's own distinctive open spaces and new residential and commercial structures.

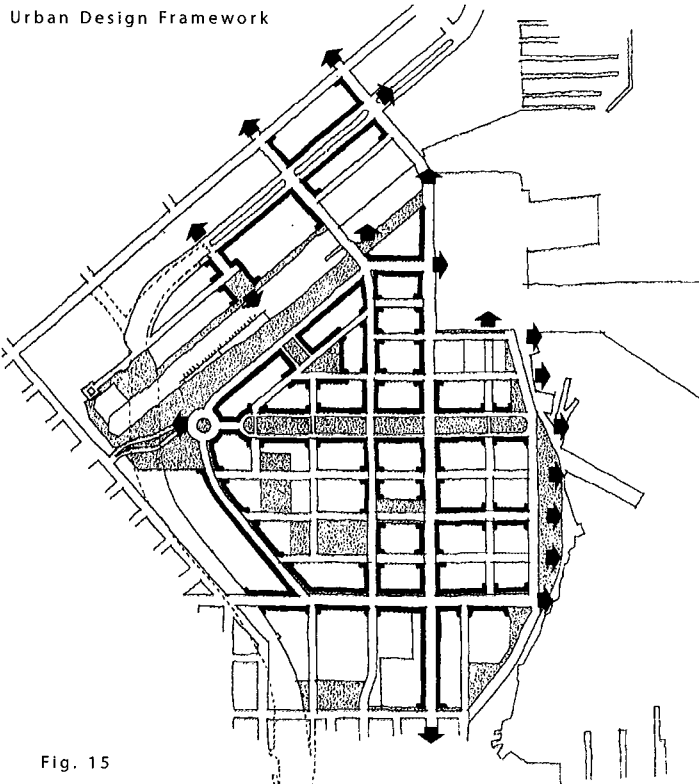

Fig. 15

# A . O p e n S p a c e G u i d e l i n e s

## A. OPEN SPACE GUIDELINES

Mission Bay South Open Space

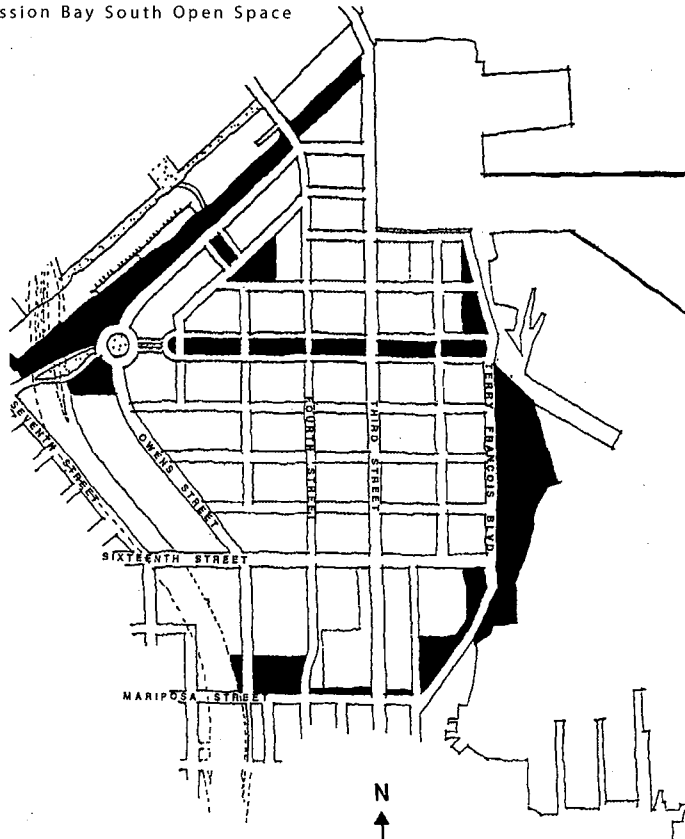

Fig. 16

The Mission Bay South open space system creates a linked system of parks, plazas, and play areas providing a variety of public amenities and spaces for passive and active recreation which are appropriate in their location and respond to adjacent uses.

The system is reinforced by its visual and physical connections to features and activities within Mission Bay South, ties into the minimum 8 acres of publicly accessible open space provided by UCSF within its campus, and integrates into the citywide distribution of public open space existing and proposed. Existing and proposed bicycle and pedestrian pathways connect the Mission Bay South Open Space and Street System with adjacent uses, surrounding neighborhoods, and the citywide network of bicycle and pedestrian routes.

It is anticipated that Mission Bay South open spaces will serve a wide range of constituents with a variety of active and passive uses. Open spaces will be designed to include essential accessory facilities, where appropriate, including bicycle parking areas and adequate lighting.

### Horticulture:

Existing soil and drainage conditions in Mission Bay are a result of the site's evolution from a bay marsh land to its present form over a period of more than fifty years and may affect successful development of proposed plant material. It is important that each parcel, as it is developed, be carefully evaluated for soil fertility and subsurface drainage quality and that the program of soil preparation, drainage and plant selection be adapted to these specific environmental conditions.

### Mission Creek Park - South Channel:

Develop the south side of the Channel (P1, P2, & P3), consistent with regulatory requirements, as a primarily green space with pedestrian pathways, children's play area, gardens, and water-oriented viewing and seating areas.

- Provide planting along Channel edge to elevation of mean low tide with vegetation compatible with each tidal zone.
- Provide reinforcement as required for bank stability and to prevent erosion, using natural materials and including vegetation where feasible.
- Remove existing concrete rip-rap and replace it with plantings from the top of bank to the water, consistent with stabilization requirements.
- Establish shoreline island and/or perch piling to support intertidal bird activity.
- Integrate design with existing Mission Creek Harbor Association, Inc. (MCHA) Park and required MCHA leasehold access and amenities.
- Continue public park between Fourth and Third Streets along the Channel, and include intertidal habitat where viable, recognizing intensive use from hotel patrons in character of landscape and use of paving materials.
- Incorporate boat storage and parking for Mission Creek Harbor.
- Integrate bike path for recreational uses.
- Develop majority of park as lawn to encourage informal recreation.
- Explore, as feasible, the development of a fresh water pond as a passive recreational opportunity and as a component of wildlife habitat, using storm/reclaimed water.

### Mission Creek Park - Bank Treatment

- If pilings must be removed, they will be replaced, if permitted by regulatory agencies, in locations acceptable to the Mission Creek Conservancy. Alternative perching opportunities may be provided acceptable to all parties.
- Consider provision of additional piling and/or floats for roosting habitat.
- Develop an appropriate vegetation program for Mission Creek that recognizes the tidal vegetation ranges: low marsh, high marsh, transition zone, and upland vegetation.
- Pickleweed will be retained to the extent possible. If existing pickleweed is disturbed, it will be replaced from existing stock as feasible.
- Maintain and expand gently sloping banks in the intertidal area to encourage foraging shore birds.
- Design storm water outfalls to minimize scouring and erosion of mudflats.

### Owens Field:

Develop Owens Field (P7, P8, P9) to accommodate a variety of zones for active recreation such as a softball field, and in areas under the freeway, compatible recreation such as skateboarding, rollerblading and basketball.

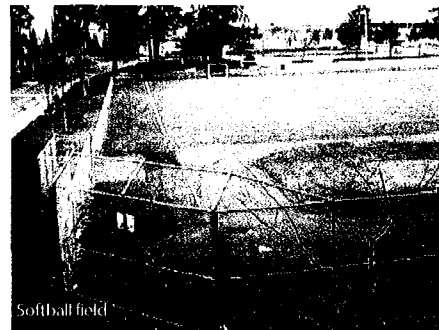

### Triangle Square:

Develop the Triangle Square (P6) as a symbolic center for the community (similar to Sidney Walton Park where a central green space accommodates flexibility in programming and use), including uses for children and families and that invite daily and active use.

- Include features that symbolically establish a link to Mission Creek.



**Mission Bay Commons:**

Design the Commons (P11, P12, P13, P15, P16, P17) as a focal point of activity similar to South Park and as a meeting ground between UCSF and Mission Bay neighborhoods.

- Reinforce views to the Bay, Buena Vista Park, and Twin Peaks from the deepest location of the Commons.
- Encourage diversity in activities and respond to surrounding land uses while providing an overall unified character.
- Develop the Commons as an inviting urban open space. Maintain design continuity and spatial definition from east to west using durable and vegetative materials and by maintaining a continuous pedestrian pathway and built edge of appropriate scale and character along its length.
- Encourage retail development on the ground floor of buildings fronting the Mission Bay Commons, between Third and Fourth Streets. Integrate small accessory concessions uses to be located in the Commons as determined feasible and appropriate.
- Allow appropriate hardscape areas to accommodate a variety of uses.

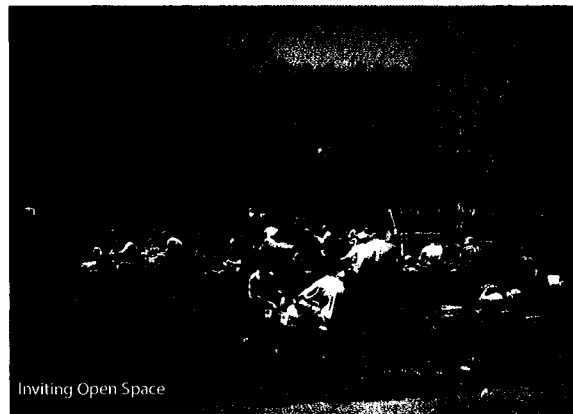

#### Bayfront Park:

Develop the park along the Bayfront, both within and adjacent to the project area, with a character predominantly defined by water-oriented activities and open flexible-use lawn areas which can accommodate a variety of passive, active and major recreation uses, such as soccer or other field related sports or informal performance areas, similar to Marina Green.

- Provide a focal point or significant design feature at the end of the Commons and integrate Commons with the design of the boat launch.
- Work with the Port to maintain essential waterfront access and integrate with Port destinations adjacent to the project area such as the existing Agua Vista Park.
- Encourage an accessory use such as a restaurant or a pavilion in areas under Port ownership with a recognition of the potential visual impact that this structure could have in the Bayfront Park and from Mission Bay streets.
- Provide pathways that link to city and regional pedestrian and bicycle trail systems, such as the continuation of the Bay Trail along the length of the eastern edge.
- Incorporate boat trailer parking.

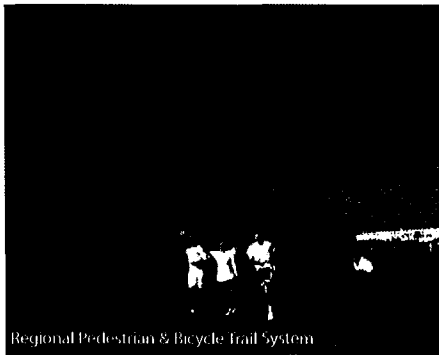

Regional Pedestrian & Bicycle Trail System

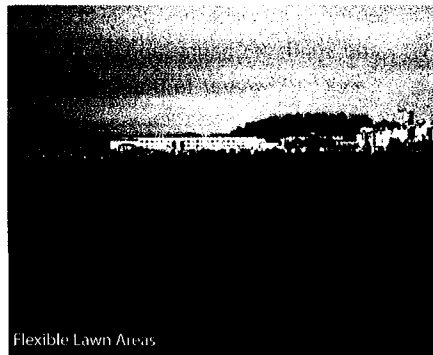

Flexible Lawn Areas



### Mariposa Walk and Parks:

Design Mariposa Park (P26) and Mariposa Bayfront Park (P25) as green, active, flexible use parks connected by Mariposa Walk , providing an open space resource to surrounding neighborhoods including Potrero Hill and a landscaped connection to the Bay.

- Mariposa Park: Develop the Mariposa Park (P26) as a green flexible use community park, available as a junior soccer field.
- Mariposa Walk: Develop a 30' wide (20' publicly accessible building setback and 10' public sidewalk) pedestrian/bicycle connection from Potrero Hill to the Bayfront Park along the northern edge of Mariposa Street.
- Mariposa Bayfront Park: Provide a neighborhood open space at the waterfront edge of Mariposa Street for waterfront viewing, community activities, picnic benches and informal play areas.
- Design utility structures to include public amenities or public art to complement surrounding open space and to minimize impacts on waterfront areas.

### Pedestrian Bridge Over Channel:

To create a pedestrian link between neighborhoods, provide a pedestrian bridge for neighborhood use across the Channel (subject to regulatory approval and designed to ensure reasonable navigable access ) in the vicinity of 5th Street effectively linking North and South of Channel and creating a pedestrian route from Fifth Street Square to Mission Creek Park, and on to Triangle Square, the Commons, and the Bay.

### Special Landscape Linkages:

Where specific sidewalks form essential linkages between and along public open space areas, consideration should be given to special landscape treatment to encourage use of these sidewalks. This might involve tree selection, additional plantings or special paving, and might be considered for linkages such as the Fifth Street extension from King Street in Mission Bay North to Triangle Square and the Commons, or for Fourth Street as an important link from Mariposa Walk to Mission Creek Park.

### Private Open Space

#### Residential Open Space:

Private residential open space, as required by the Design Standards, may consist of open space for an individual unit or common usable open space shared by residents. The requirements can be satisfied in a number of ways and in a variety of areas such as:

- Individual unit open space: patios, terraces, or balconies adjacent to the unit.
- Common open space: mid-block lanes (provided they do not permit through traffic other than emergency vehicles), gardens, building courtyards at grade level, arcades, rooftop and parking podium level gardens, decks, solaria, and atria open to sun and air, open terraces or recreational facilities.
- Where feasible, the residential open space should maximize sunlight and be oriented to significant natural features such as the Channel and the Bay.
- Private open space, where feasible, should enhance public open space areas utilizing design features such as: views to private open space from sidewalks and parks, enhanced walkways and pedestrian linkages, and similar measures.

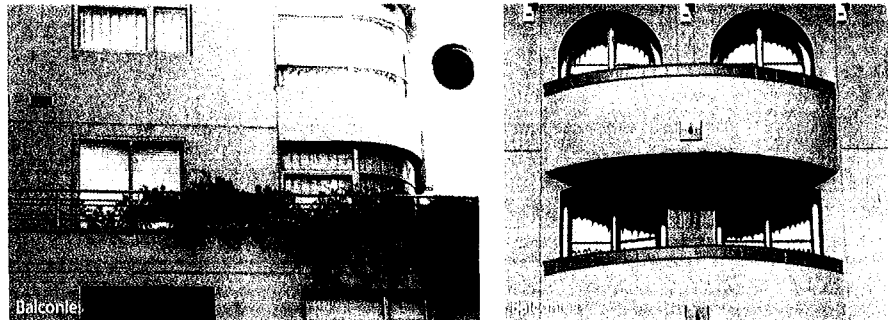

**Rooftop Recreation/Community Structures:**

For rooftop recreation/community structures as permitted in the design standards:

- The walls enclosing such structures are set back from the roof perimeter in such a way that they are not visible from the opposite sidewalk along the adjoining street.
- The walls enclosing such structures should be predominately transparent (clear glass or open).

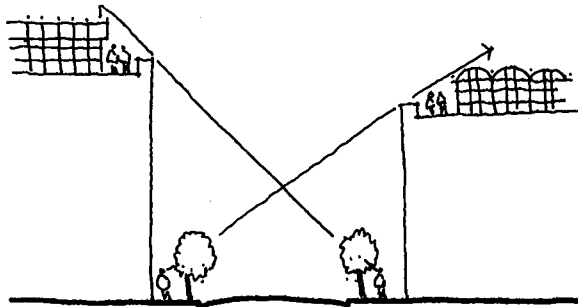
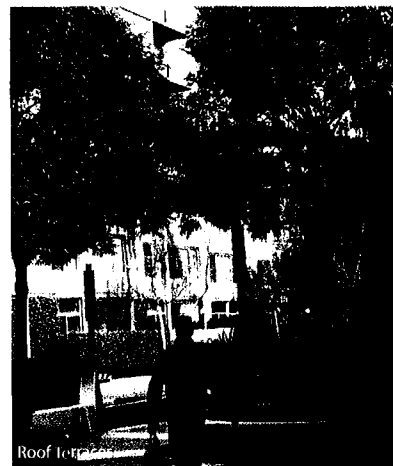

Fig. 17 Rooftop Community Structures



---

# B . R e s i d e n t i a l   G u i d e l i n e s

## B. RESIDENTIAL GUIDELINES

The Mission Bay South Residential District, located in the northern portion of the Plan Area is a mix of market-rate and affordable family units, and neighborhood retail, forming a tightly knit urban community in the heart of an emerging, vibrant mixed use district in San Francisco.

Situated along major access routes, and bordered by UCSF to the south, and the Channel to the north, the District combines the excitement of living in a bustling city with the potential for respite through orientation towards the Channel, neighborhood parks, the Bayfront, and the life of mid block open spaces.

It is envisioned as a district of walkable streets with a network of private and public open spaces. It is a district that is built to the street edge with a lively pedestrian-friendly ground level of residential entries, neighborhood stores, and well designed sidewalks. It is a district of buildings that are sensitively scaled and that accommodate variations in design features and materials, providing interest and character in a way that is reminiscent of the best architecture of San Francisco.

Residential Guidelines, outlined and illustrated in the following pages provide recommendations for all new housing construction on blocks designated Mission Bay South Residential in the Land Use Plan on page 20.

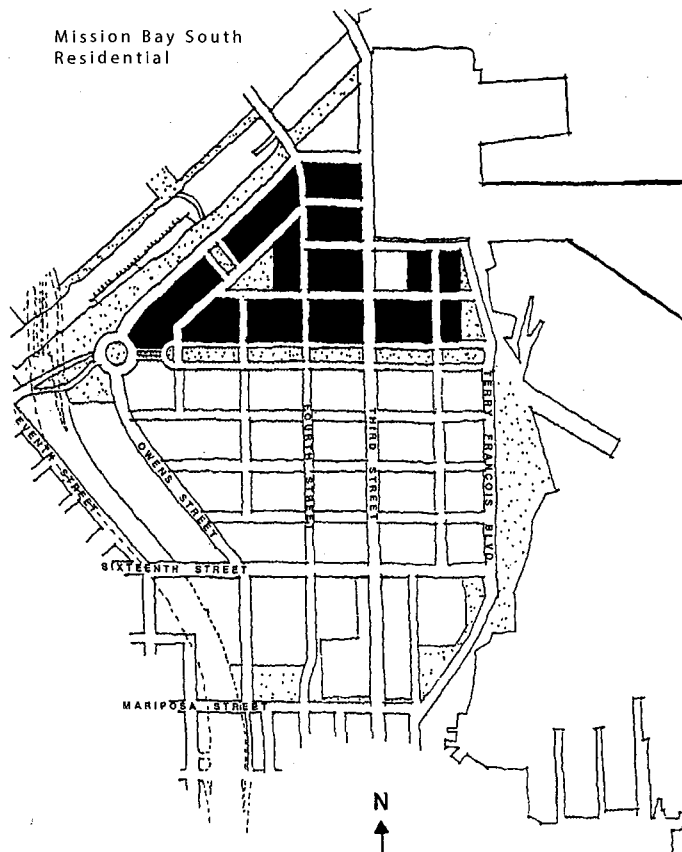

Fig. 18

**Mid-Block Walkways:**

- Mid-block lanes should complement the primary street system, and shall be publicly accessible during daylight hours.
- To promote better pedestrian access and modulate the scale of development, additional mid-block lanes may be provided (in addition to these required on Blocks 12 & 13 as outlined in the Design Standards). These mid-block lanes may be for pedestrians only or may also provide vehicular access, additional building frontage, and on-street parking.

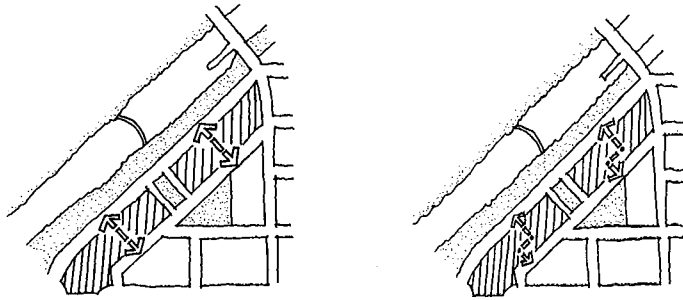

Fig. 19 Mid-Block Walkway Examples on Blocks 12 & 13





#### View Corridors:

In a few locations in Mission Bay, view corridors may terminate in buildings rather than in vistas. These visual termination points are important architectural opportunities and should be designed in a matter that reflects their importance.

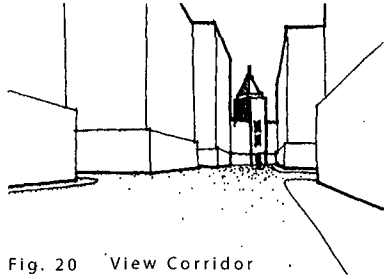

Fig. 20 View Corridor

**Streetwall and Setbacks:**

Residential buildings should be continuous at the property line on streets, except for occasional breaks in the streetwall for entry to a courtyard, building, or mid-block lanes.

- Other streets not specifically mentioned in the Design Standards are also encouraged to have continuous streetwalls.
- While mid-block lanes should also be designed to generally adhere to these guidelines, they may include more generous setbacks to create additional open space.
- Certain streets have mandatory setbacks from the property line and are identified in the section on Setbacks in the Design Standards. Streetwall guidelines should be observed at the boundary of these setbacks.

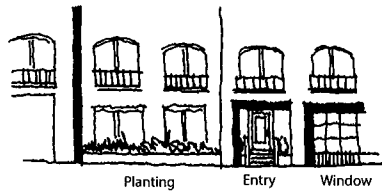

Fig. 21 Streetwall Setbacks

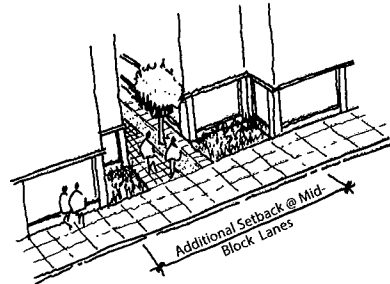

Fig. 22 Additional Setback for Mid-block Lanes



#### Pedestrian Scale:

At the ground level, the design and scale of building facades and sidewalks should enhance the pedestrian experience by being visually interesting, active, and comfortable.

- Neighborhood-serving retail, where feasible, is encouraged on the ground floor of residential buildings. Guidelines that specifically address neighborhood retail are discussed in the Retail Guidelines.
- Residential uses at or near street level enliven the pedestrian experience, as well as foster a sense of community and safety. Privacy issues for residents should be considered along with opportunities for direct access to the street.
- Buildings at street level should create pedestrian scale and interest by minimizing the use of blank walls and incorporating architectural and landscape features of interest and utility.  
(See following sub-section on Architectural Details for suggested design character for building bases at the street level.)
- Attention should be given to the choice of trees, sidewalk details, and street furniture in order to maintain pedestrian scale.  
(See section on Street Guidelines for specific recommendations on streetscape design.)



Residential at Street Level

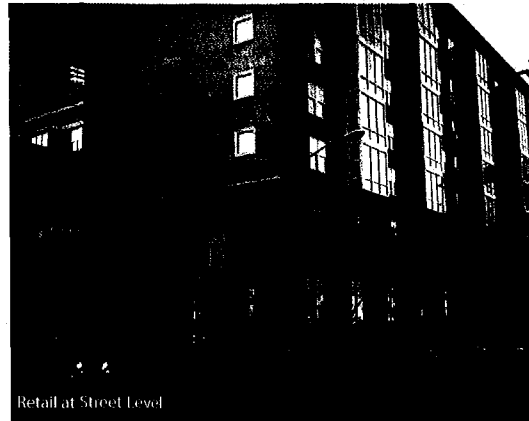

Retail at Street Level

Entries:

Frequent residential entries are encouraged to create the fine-grained, pedestrian-oriented streets that are characteristic of San Francisco neighborhoods.

- For larger buildings with shared entries, entry should be through prominent entry lobbies or central courtyards facing the street. From the street, these entries and courtyards can provide visual interest, orientation, and a sense of invitation.
- Provide multiple entries at street level where appropriate, if consistent with security and other concerns.
- Ground floor residential units are encouraged to have their principal entrance from the neighborhood streets where feasible.

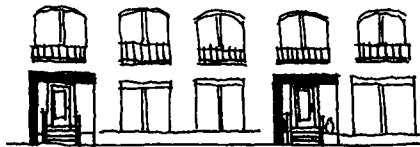

Fig. 23 Residential Entries

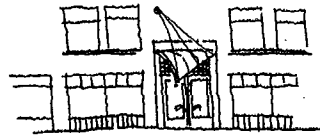
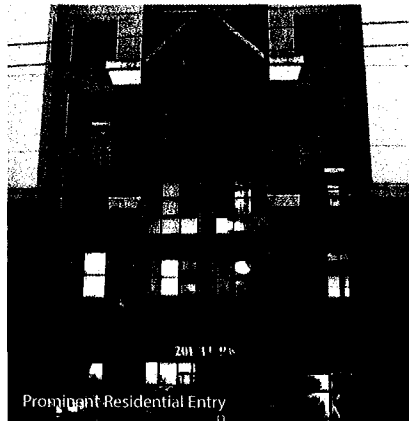

Fig. 24A Prominent Residential Entries



Fig. 24B Prominent Residential Entries



## Building Height & Form

### Height Locations:

The predominant residential height zone in Mission Bay North allows buildings to a maximum of 65'. Mid-rise buildings up to 90' high and towers up to 160' may be constructed within a percentage of the developable area of each height zone as indicated in the Design Standards

- It is anticipated that within the residential areas of Mission Bay, there will be a range of building heights as is typical in high density San Francisco neighborhoods. Many of the developments will be around 50' tall, and developments along the Channel will have an average streetwall height of 50'. The height of residential buildings should generally step down to the Channel and the Bay.
- The placement of 160' tall buildings should mark significant areas and reinforce locations of more intense activity along King Street, Third Street, Fourth Street and Fifth Street (e.g. major intersections, transit stops, and gateways) and preserve, frame, and enhance views and view corridors. Their location should also be sensitive to the fact that seen together, these buildings will determine the skyline character of Mission Bay.
- Traditional development patterns in older San Francisco neighborhoods also provide a model for reference including three story buildings typically modulated at approximately 25' increments, four story buildings at 50'-100' increments, and taller buildings at approximately 100'.
- Towers directly along Channel Street should be oriented with the short facade facing the park.



Fig. 25 Vertical Articulation

**Skyline Character:**

Skyline character is a significant component of the overall urban composition that is San Francisco and the guidelines encourage developments which will complement the existing city pattern and result in a new, attractive view element as seen from nearby vantage points.

- Locate taller buildings in clusters so as to establish a distinctive and memorable skyline which reinforces activity and density patterns in Mission Bay.
- Reflecting their importance in the skyline and in deference to prevailing San Francisco patterns, tall buildings should avoid unusual shapes which detract from the clarity of urban form by competing for attention with buildings of greater public significance.
- Recognizing the views of the site from the north, variety in building heights, massing, and building articulation are recommended to promote visual variety and reduce the scale of development.
- Towers should be expressed as vertical elements. If a tower element is adjacent to a mid-rise element, the tower should be distinguished visually. Methods to consider for such tower articulation include stepbacks or other design treatments (such as a vertical “notch”) that set the tower apart visually.

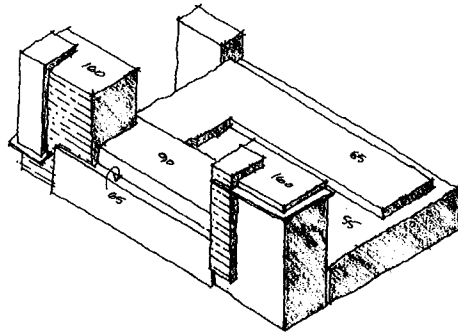

Fig. 26 Tower Articulation: stepback

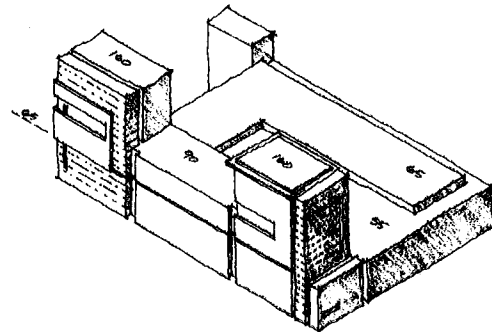

Fig. 27 Tower Articulation: “notch”

#### Building Base:

For pedestrians, the character of the building base is particularly important in establishing a comfortable scale and environment.

- Variety at street level for pedestrian scale can be achieved through the use of design features such as stairs, stoops, porches, bay windows, rusticated materials and landscaping.

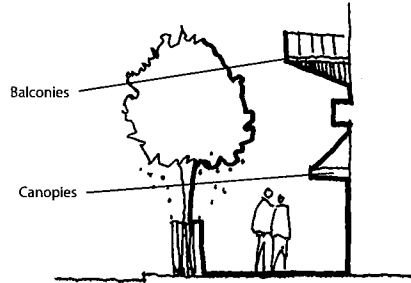
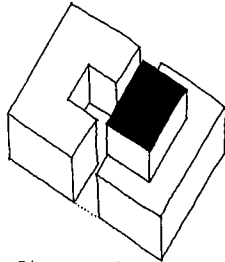

Fig. 28 Building Base



- In the case of taller buildings, setbacks above the tower base should not be so significant that towers have no presence at the ground level.
- Towers should be expressed as vertical elements and integrated into the overall design of the structure.

Not Recommended



Recommended

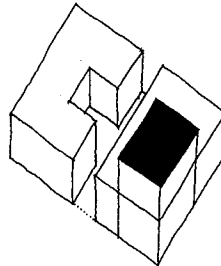
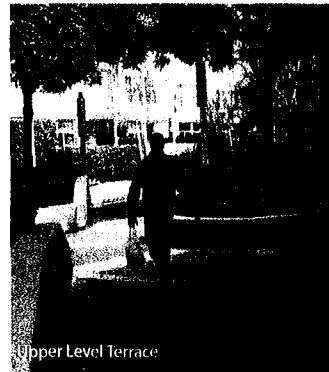

Fig. 29 Tower Placement

**Roofscape:**

Recognizing that Mission Bay South building roofs may be visible from higher surrounding locations, they should be designed consistent with the architecture of the building.

- Roofs should be visually interesting and should use non-reflective, low intensity colors.
- Mechanical equipment should be organized and designed as a component of the roofscape and not appear to be a leftover or add-on element. Mechanical equipment should be screened as provided in the Design Standards.
- Upper level terraces on residential buildings, particularly on the roof of parking podiums, are encouraged, and if improved, may qualify as required private open space.





Architectural Details

Visual Interest:

To mitigate the scale of development and create a pedestrian friendly environment, building massing should be modulated and articulated to create interest and visual variety.

- A selection of architectural details such as vertical and horizontal recesses and projections, changes in height, floor levels, roof forms, parapets, cornice treatments, window reveals and forms, color, and location of garage and residential entries, as appropriate to each site can create shadows and texture and add to the character of a building.

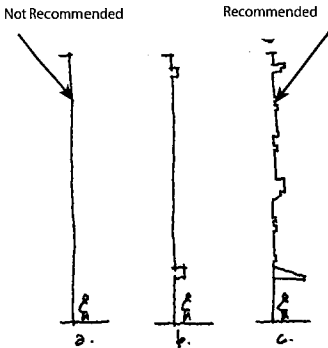
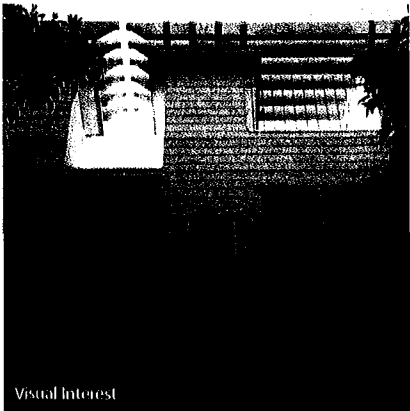
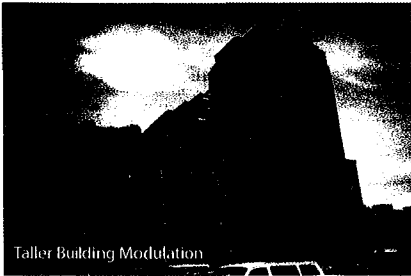

Fig. 30 Architectural Details Create Visual Interest



- As is common in San Francisco Neighborhoods, building variety on a block is desired while maintaining a consistent street frontage.
- Tall buildings should reflect the San Francisco building pattern of base, shaft, and capital separated by cornices, string courses, setbacks, and other articulating features.

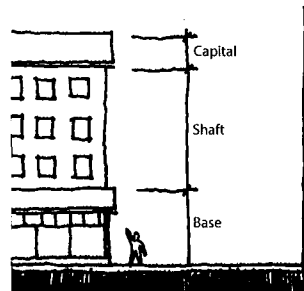

Fig. 31 Base, Shaft, Capital  
- A Typical San Francisco Building Pattern



#### Color and Materials:

Extreme contrasts in materials, colors, shapes and other characteristics which will cause buildings to stand out in excess of their public importance should be avoided.

- Taller buildings should avoid dark tones thereby reinforcing the visual unity and special character of the City.

Corner Zone:

Each street corner site in the Plan Area offers an opportunity to maximize views and sunlight exposure. To realize this advantage and encourage architectural variety, each corner should hold the street wall by building to the street face for a minimum distance of 50' as outlined in the Design Standards.

- Corner buildings should be given special architectural treatment to make them stand out from the building pattern along the rest of the block.

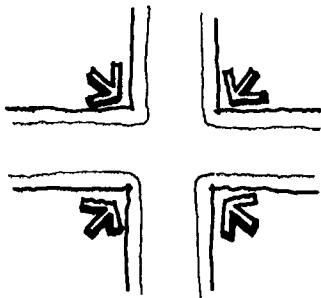

Fig. 32 Build to Corner

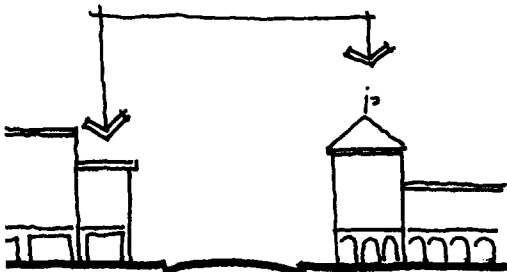

Fig. 33 Mark Corners

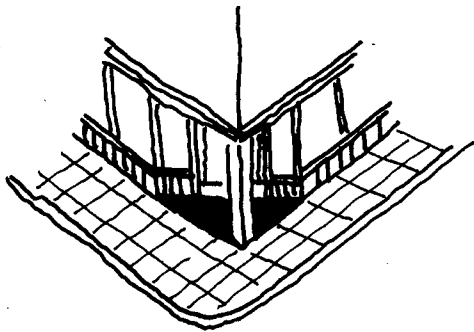

Fig. 34 Corner Pass Throughs



Prominent Corner

## C. Commercial Industrial Guidelines

## C. COMMERCIAL INDUSTRIAL GUIDELINES

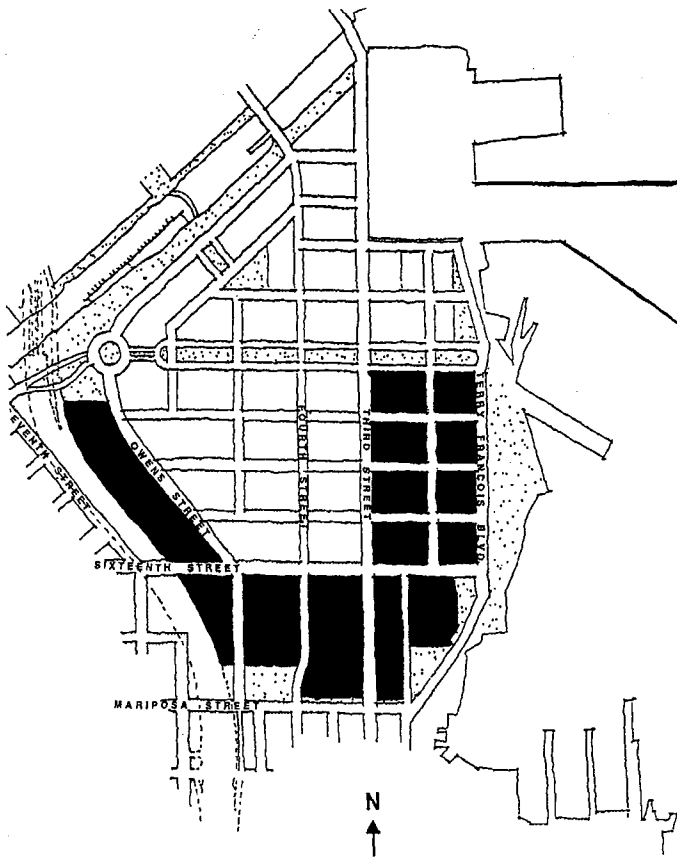

Fig. 35 Mission Bay South Commercial Industrial

The following guidelines refer to uses such as office, research and development, light industrial, general commercial and retail uses in areas designated Commercial Industrial and Commercial Industrial Retail in the Plan Area. It is anticipated that these commercial uses will complement the planned UCSF research campus and will contribute to the mixed-use vibrancy of the Mission Bay community. The guidelines encourage an active and visually interesting pedestrian environment and building placement and character that will give the commercial areas a distinctive identity and one that will complement the overall visual perception of Mission Bay.

## View Corridors:

View corridors are defined by the Mission Bay street grid. No building, or portion thereof, shall block a view corridor established by that grid of streets and dedicated right-of-ways.

- The view corridors serve primarily to retain views to the Bay, the Channel, and the downtown skyline, and to reinforce visual linkages between the UCSF campus and surrounding development.
- In a few locations in Mission Bay (e.g. near the Freeway and on Blocks 29-32 to accommodate an Event Center Project), view corridors may terminate in buildings rather than in vistas. These visual termination points are important architectural opportunities and should be designed in a manner that reflects their importance. **The building design of an Event Center and its accessory structures should terminate these vistas and internal circulation and complement publicly-accessible pedestrian routes with functional and attractive responses to the public realm. Transparent façades and/or layered views to development beyond the property line, and in particular to dramatic views of the Event Center Building and its accessory structures, should be prioritized.**



Fig. 36 View to Bay

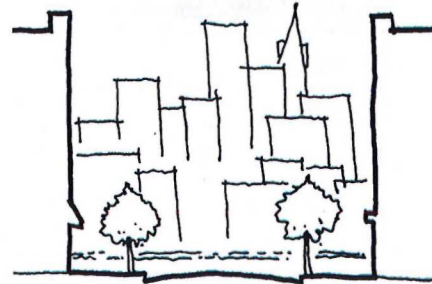

Fig. 37 View to City

### Open Spaces:

Encourage the development of publicly-accessible open spaces at ground level. Where feasible, design these open spaces in relation to local serving retail such as cafes and to the public open space network.

- Public right-of-ways in the Commercial Industrial area that are not needed for vehicular access should be considered for open space and pedestrian uses.



Fig. 38 Ground Floor Open Space



### Pedestrian Walkways:

Walkways are encouraged to enhance the pedestrian experience in the Commercial Industrial area.

- Walkways to mid-block open spaces or courtyards are encouraged.
- In the large blocks between 16th and Mariposa Streets, and along the freeway, mid-block pedestrian and/or service-only or parking access lanes are encouraged in the east-west direction to provide needed access and reduce the scale of these blocks.

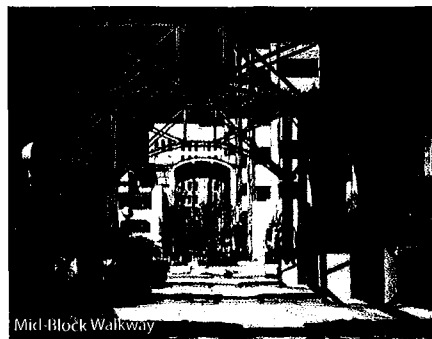

**Streetwall:**

Commercial areas in San Francisco are noted for streets with buildings at the property line where there is little or no space between buildings. This historical pattern of development gives San Francisco its intense urban quality and should be a model for Mission Bay development. Commercial Industrial buildings should be continuous at the property line on streets, except for occasional breaks in the streetwall.

- Setbacks up to 10' from the property line are allowed within a continuous streetwall.
- Variations from the streetwall are allowed to create open space, pedestrian circulation space, mid-block lanes, and landscaping areas. However, open spaces should not be so frequent or close together that they undermine the sense of a continuous streetwall.
- Other streets not specifically mentioned in the Design Standards are also encouraged to have continuous street walls.
- Buildings along Terry Francois Boulevard are encouraged to provide variety within the streetwall and visual relief for the Bayfront Park. This streetwall variety may include techniques such as surface articulation, variation of planes, wall surfaces, and heights, differences in materials and colors, as well as the placement of stepbacks, courtyards, plazas, and other features.

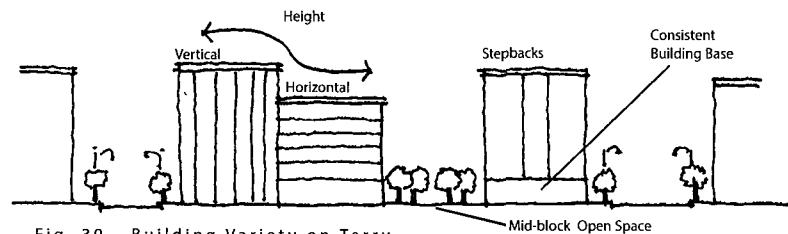

Fig. 39 Building Variety on Terry Francois Blvd.



Street Frontage

Streetwall Height:

Within high density commercial areas of San Francisco such as downtown and south of Market, a typical ratio of street width to streetwall height is approximately 1:1.25.

- The building-street relationship in Mission Bay Commercial Industrial areas should reflect this city pattern.

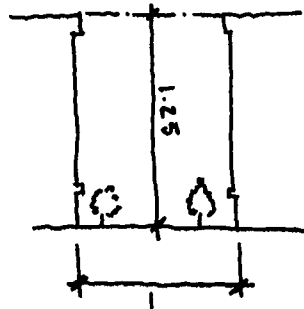

Fig. 40 Streetwall Height



Pedestrian Scale:

Office and other commercial buildings are encouraged to be active and to incorporate visually interesting details and/or decoration into the design of the building base.

(See subsection on Architectural Details for specific guidelines towards creating visual interest and variety.)

- Where a substantial length of windowless wall is found to be unavoidable, a contrast in wall treatment, outdoor seating and/or landscaping should be used to enhance visual interest and pedestrian area vitality, thereby eliminating blank walls.



Fig. 41 Pedestrian Scale on Blank Walls

Curb Cuts:

In order to preserve the continuity and quality of the pedestrian environment, curb cuts for parking and service uses are strongly discouraged along Third Street.

### Height Locations:

The predominant commercial height zone in Mission Bay allows buildings to a maximum of 90' high. Buildings up to 160' high may be constructed within a percentage of the developable area of each height zone as indicated in the Design Standards.

- The placement of buildings up to 160' tall should mark significant areas along Third Street, Sixteenth Street, and the Freeway (e.g. major intersections, transit stops, and gateways), reinforce major destinations and elements within Mission Bay, and preserve, frame and enhance views and view corridors.

### Skyline Character:

Skyline character is a significant component of the overall urban composition that is San Francisco and the guidelines encourage developments which will complement the existing city pattern and result in a new, attractive view element as seen from nearby vantage points.

- Tall building locations should also be selected with a recognition that taller buildings in particular, when seen together, will create the skyline character of Mission Bay South.
- Locate taller buildings in clusters so as to establish a distinctive and memorable skyline which reinforces activity and density patterns in Mission Bay South.
- Recognizing the views of Mission Bay from surrounding areas, variety in buildings heights, massing, and building articulation are recommended to promote visual variety and reduce the scale of development.
- Reflecting their importance in the skyline and in deference to prevailing San Francisco patterns, tall buildings should avoid unusual shapes which detract from the clarity of urban form by competing for attention with buildings of greater public significance.
- **Where tall buildings are constructed as civic amenities and symbolic spaces, unusual shapes and iconic architecture are encouraged to emphasize public significance within the urban form of the existing skyline.**

### Building Height & Form

#### Freeway Zone:

Mission Bay buildings near to the 280 Freeway (Height Zone HZ-7) should take into account their importance in establishing a design character for the area, as seen from surrounding neighborhoods and from a highly traveled regional access route, and in contributing to a dramatic and attractive arrival sequence for the City of San Francisco. Issues of building placement, massing, facade materials and height are all important in this consideration.

- Separation and Placement of Towers - Taller buildings, above the typical 90' base in this district, should be separated by a distance of 200' and should be oriented perpendicular to Owens Street wherever possible.
- Lower Elements at Freeway Frontage - Lower portions of the buildings on each parcel should be oriented to give variety to the area views and "breathing space" for motorists. Along 60% of the freeway frontage of each parcel and for a depth of 100' from the freeway, buildings should hold to a maximum height, including any projection above the building height, equal to the average height of that portion of the freeway adjacent to the parcel. The freeway height should be measured to the top of the edge barriers. Due to its unusual configuration and limited developable area, within parcel 40 the above guideline applies only to the special height area defined on the Height Zone Map.
- Open Space/Panorama - In the northern portion of Height Zone HZ-7, parcel 43 has particular restrictions designed to preserve a portion of the downtown panorama. On parcel 43, in addition to the freeway edge, all portions of buildings within the special height area adjacent to Owens Field, as defined on the Height Zone Map, are limited to a height, including any projection above the building height, equal to the average height of the freeway barriers adjacent to the parcel with the exception of a maximum 90' base building and/or tower located toward the southeast corner of the parcel, which is outside of the special height area.
- Any tower, i.e., portion of a building above 90 feet, to be constructed on Block 40 should be sited and shaped in a way to retain the broad view to downtown from the Interstate 280 freeway, to the greatest extent feasible. The viewpoint is defined as being from the north-bound lanes of the Interstate 280 freeway, extending north from the point where the freeway crosses under Eighteenth Street to a point 100 feet north of Mariposa Street.

- Building Design - Recognizing their prominent location, buildings along the freeway should be visually interesting, articulated, and generally light in tone, and should avoid the use of reflective glass. Careful consideration should be given to the visual experience of residents in surrounding areas and users of the adjacent freeway.

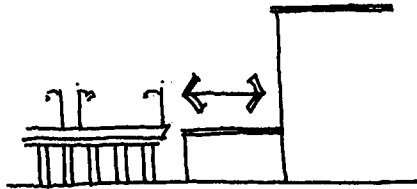

Fig. 42 Lower Elements at Building Frontage

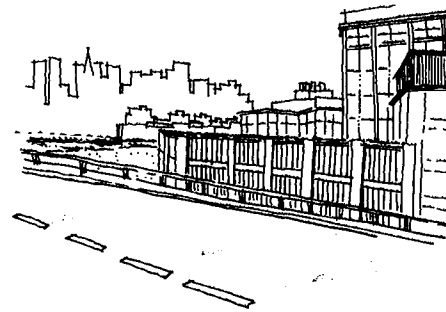

Fig. 43 Open Space/Panorama

#### Building Base:

For pedestrians, the character of the building base is important in establishing a comfortable scale and environment and should be designed to achieve this. (See the following sub-section on Architectural Details for specific recommendations.)

- Variety at street level for pedestrian scale can be achieved through the use of design features such as stairs, entries, expressed structural elements, arcades, projections, rusticated materials, and landscaping.
- In the case of taller buildings, setbacks above the tower base should not be so significant that towers have no presence at the ground level.
- Towers should be expressed as vertical elements and integrated into the overall design of the structure.

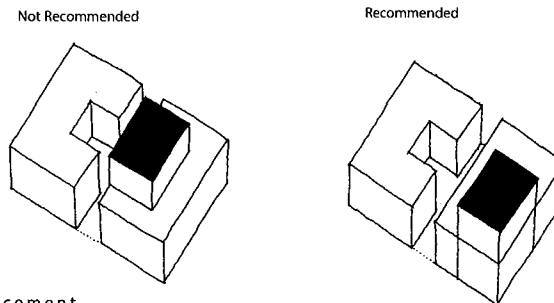

Fig. 44 Tower Placement

#### Roofscape:

Recognizing that Mission Bay building roofs may be visible from higher surrounding locations, they should be designed consistent with the distinctive architecture of the building.

- Roofs should use non-reflective, low intensity colors.
- Mechanical equipment should be organized and designed as a component of the roofscape and not appear to be a leftover or add-on element. Mechanical equipment should be screened as provided in the Design Standards.

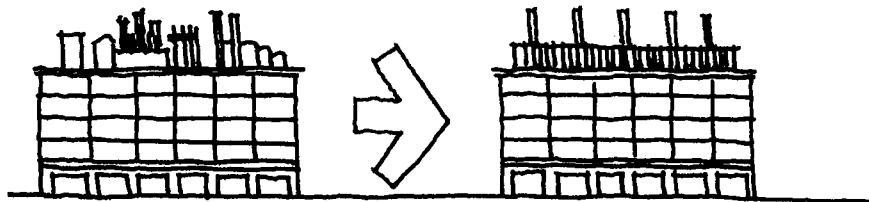

Fig. 45 Screen Mechanical Equipment



**Visual Interest:**

To mitigate the scale of development and create a pedestrian friendly environment, building massing should be modulated and articulated to create interest and visual variety.

- A selection of architectural details and devices such as vertical and horizontal recesses and projections, changes in height, floor levels, roof forms, parapets, cornice treatments, window forms, and location of garage entries, as appropriate to each site can create shadows and texture and add to the character of a building.

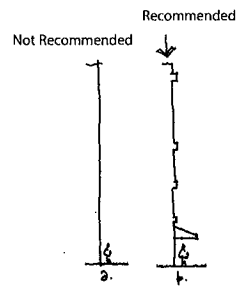

Fig. 46 Architectural Variety Creates Visual Interest

- Variety in building heights is encouraged to promote visual interest and modulate the scale of development, especially along the Bayfront. Strong horizontal and vertical elements also serve to modulate the scale of development and create interesting streetscapes for pedestrians.
- Tall buildings should reflect the San Francisco building pattern of base, shaft, and capital separated by cornices, string courses, stepbacks and other articulating design features.
- Buildings along the Bayfront Park should avoid homogeneous and unrelieved facades.

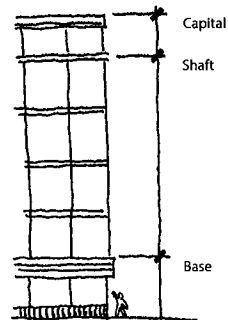
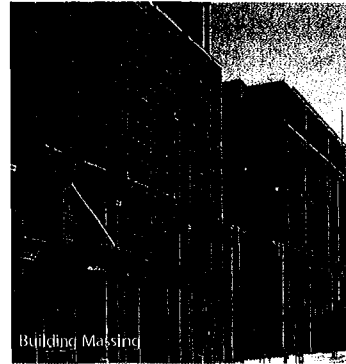
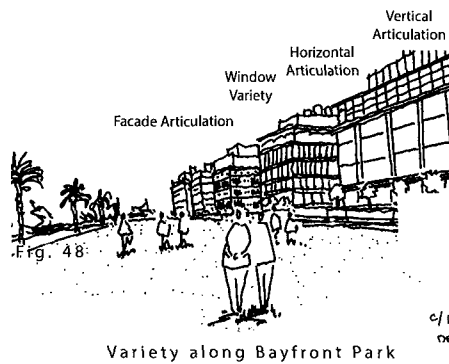

Fig. 47 Base, Shaft, Capital - A Typical San Francisco Building Pattern

### Architectural Details

Extreme bulk and massive appearance of facades should be reduced. These efforts may include variation of planes and wall surfaces, fenestration, height variation, and differences in materials or colors and surface articulations.



#### Color and Materials:

Extreme contrasts in materials, colors, shapes and other characteristics which will cause buildings to stand out in excess of their public importance should be avoided.

- As consistent with the general visual character of the City, buildings should be light in tone, particularly if they are highly visible on the skyline.

## D . R e t a i l G u i d e l i n e s



## D. RETAIL GUIDELINES

---

Retail guidelines refer to the range of retail and mixed-use development that is anticipated throughout the Plan Area development. Much like other neighborhoods in San Francisco, Mission Bay South will have a wide variety of retail services for its residents, workers, and visitors including shops that serve the needs of residents, stores that attract residents from throughout the City, and retail/entertainment that is a regional destination. The goal of the guidelines is to integrate the retail development with the anticipated residential and commercial uses making Mission Bay South a vibrant and inviting mixed-use neighborhood.

---

## NEIGHBORHOOD-SERVING RETAIL\*

The following guidelines refer to neighborhood retail uses in residential and commercial areas throughout the Mission Bay South area. The guidelines are directed at integrating neighborhood retail activities into neighborhoods as is typical throughout San Francisco.

\* Referred to as “local-serving retail” in the Redevelopment Plan.

## Street Frontage

### Neighborhood Retail Locations:

Neighborhood retail uses are permitted throughout the Mission Bay South area, and are encouraged near major intersections, open spaces, and at transit stops.

- In the Plan Area, neighborhood retail uses are primarily encouraged on Third Street near light rail stops along 4th Street and along the Commons.

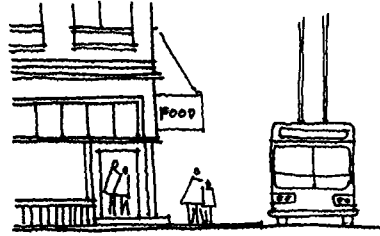

Fig. 49 Neighborhood Retail

### Pedestrian Scale:

In neighborhood retail areas, street level frontage should be primarily devoted to entrances, shop windows, or other displays.

- Clear, untinted glass should be used at and near the street level to allow maximum visual interaction between sidewalk areas and the interior of buildings.
- Where a substantial length of windowless wall is found to be unavoidable, eye-level displays, a contrast in wall treatment, outdoor seating and/or landscaping should be used to enhance visual interest and pedestrian area vitality.
- Buildings at street level might also create pedestrian scale and interest by minimizing blank walls and incorporating architectural features of interest and utility. (See following sub-section on Architectural Details for suggested design character for building bases at the street level.)

**Setbacks:**

In order to maintain a continuous block facade line, building setbacks beyond the 5' allowed are discouraged for neighborhood retail.

- Outdoor features and activities such as arcades, sidewalk cafes and walk-up windows may be accommodated by recessing the ground story.

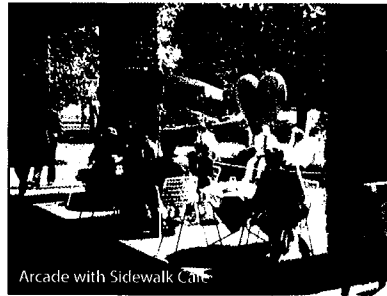

**Corner Stores:**

The typical San Francisco pattern of corner store entrances and corner bay windows is encouraged in neighborhood retail districts.

- Other traditional elements of San Francisco corner stores, such as raised corner parapets and free-standing corner columns should also be considered.



Fig. 50 Corner Store

### Street Frontage

#### Curb Cuts:

In order to preserve the continuity and quality of the pedestrian environment, curb cuts for parking and service uses are strongly discouraged within neighborhood retail frontages.

#### Facades:

Neighborhood retail facades should be compatible with the proportions and design features of the residential and commercial facades above and the facades of adjacent buildings.

- Architectural detailing is encouraged to create visual variety and maintain pedestrian scale.

## CITY-SERVING RETAIL USES WITHIN COMMERCIAL INDUSTRIAL LAND USE

The following guidelines refer to city-serving retail uses in commercial areas in parcels 29, 30, 31, 32, 36, 37, X3, and X4 in Mission Bay South. City-serving refers to retail uses offering goods and services to a population greater than the immediate neighborhood. The guidelines are directed at integrating such retail activities into the fabric of Mission Bay and minimizing impacts they have on the adjacent residential neighborhoods.

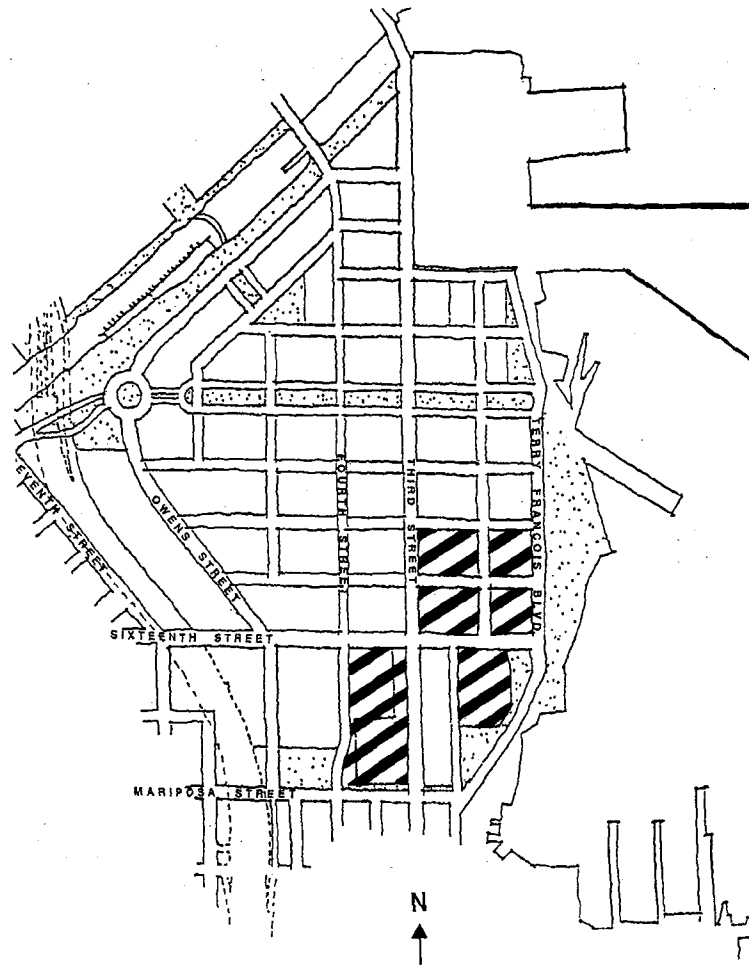

Fig. 51 City-Serving Retail Locations

## Street Frontage

### Pedestrian Scale:

Large-scale city-serving retail developments should attempt to maintain an inviting pedestrian experience on the street. Street level frontage, where feasible, should be primarily devoted to entrances, shop windows, displays, or other visually interesting features.

- Clear, untinted glass should be used at and near the street level to allow maximum visual interaction between sidewalk areas and the interior of buildings.
- Buildings at street level might also create pedestrian scale and interest by eliminating blank walls and incorporating architectural features of interest and utility such as a contrast in wall treatment and/or landscaping.
- In city-serving retail, streetscapes are particularly important in maintaining pedestrian scale. Attention should be given to elements that enhance the pedestrian experience such as landscaping, sidewalk details, hardscape areas, street furniture. (See section on Street Guidelines for specific recommendations on streetscape design.)



Fig. 52 Visually Interesting Pedestrian Scale

An attempt should be made to maintain a continuous block facade line consistent with block development throughout Mission Bay.

- Where feasible, the buildings should be sited at the property line on Third Street.
- On Mariposa Street, the required 20 feet setback from the property line will establish the Mariposa streetwall edge. Buildings should be sited at this streetwall line where ever feasible. Exceptions for outdoor activities such as arcades, sidewalk cafes and walk-up windows may be accommodated by recessing the ground story.
- An attempt should be made to orient parking areas away from Third and Mariposa Streets.

**Curb Cuts:**

In order to preserve the continuity and quality of the pedestrian environment in City-Serving Retail areas, curb cuts for parking and service uses are strongly discouraged along Third Street.

- One area where a curb cut or the addition of a mid-block access road or pedestrian Street may be considered is the long block from 16th Street south to Mariposa.



---

# E . H o t e l G u i d e l i n e s

# E. HOTEL GUIDELINES

The following guidelines are directed at integrating the planned hotel development on Block 1 in the Plan Area with the quality and character of the overall Mission Bay development. It is expected that this block will include a 500 room hotel with retail/entertainment, restaurants, and conferencing facilities.

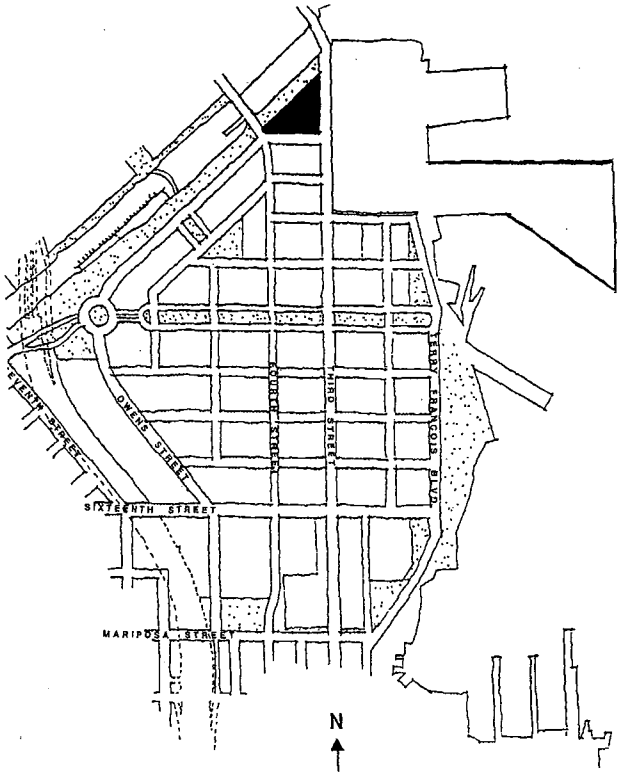

Fig. 53 Mission Bay South Hotel

Open Space:

Hotel development along Mission Creek Park should be sensitive in scale to the adjacent open space and should locate active uses along the Channel that complement the character and quality of the space.

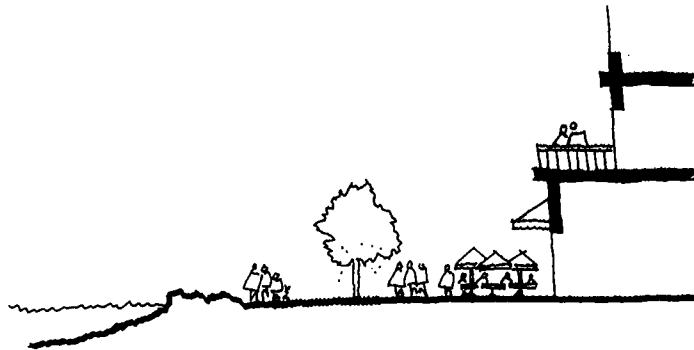

Fig. 54 Open Space with Adjacent Active Uses

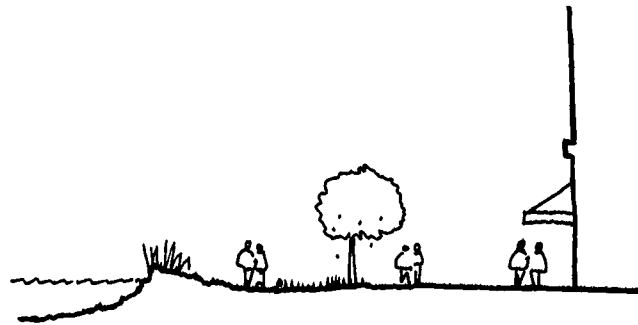

Fig. 55 Open Space with Adjacent Retail Frontage

### D Street Frontage

#### Pedestrian Scale:

Buildings at the street level and along Mission Creek Park should be active, interesting, and pedestrian-friendly.

- Variety and interest may be achieved by using significant transparency of built forms, vertical modulations, and street level activities.
- Where feasible, orient public functions such as restaurants, retail, and lobby areas to public streets and public areas on Mission Creek.
- In retail areas, clear, untinted glass should be used at and near the street level to allow maximum visual interaction between sidewalk areas and the interior of buildings.
- Where a substantial length of windowless wall is found to be unavoidable, eye-level displays, a contrast in wall treatment, offset wall line, outdoor seating and/or landscaping should be used to enhance visual interest and pedestrian area vitality.

#### Streetwall:

In order to maintain a continuous block facade line, building setbacks are discouraged along principal streets, with the exception of drop-off areas.

### Skyline Character:

Skyline character is a significant component of the overall urban composition that is San Francisco and the guidelines encourage developments which will complement the existing city pattern and result in a new, attractive view element as seen from nearby vantage points.

- Reflecting their importance in the skyline and in deference to prevailing San Francisco patterns, tall buildings should avoid unusual shapes which detract from the clarity of urban form by competing for attention with buildings of greater public significance.
- Recognizing the views of the site from the north, variety in building heights, massing, and building articulation are recommended to promote visual variety and reduce the scale of development.

### Building Base:

For pedestrians, the character of the building base is important in establishing a comfortable scale and environment and should be designed to achieve this.

(See the following sub-section on Architectural Details for specific recommendations.)

- In the case of taller buildings, setbacks above the tower base should not be so significant that towers have no presence at the ground level.
- Towers should be expressed as vertical elements and integrated into the overall design of the structure.

### Roofscape:

Recognizing that Mission Bay South building roofs may be visible from higher surrounding locations, they should be designed as an integral element of the building.

- Roofs should be visually interesting and should use non-reflective, low intensity colors.
- Mechanical equipment should be organized and designed as a component of the roofscape and not appear to be a leftover or add-on element. Mechanical equipment should be screened as provided in the Design Standards.
- Usable roof terraces on building bases should be considered for gardens, restaurants, pools and other such amenities.

**D** Architectural Details

**Visual Interest:**

To mitigate the scale of development and create a pedestrian friendly environment, building massing should be modulated and articulated to create interest and visual variety.

- A selection of architectural details such as vertical and horizontal recesses and projections, changes in height, floor levels, roof forms, parapets, cornice treatments, window forms, and location of garage entries, as appropriate can create shadows and texture and add to the character of a building.
- Tall buildings should reflect the San Francisco building pattern of base, shaft, and capital separated by cornices, string courses, stepbacks and other articulating design features.

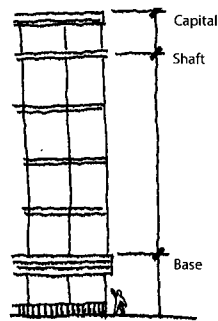

Fig. 56 Base, Shaft, Capital  
- A Typical San Francisco Building Pattern

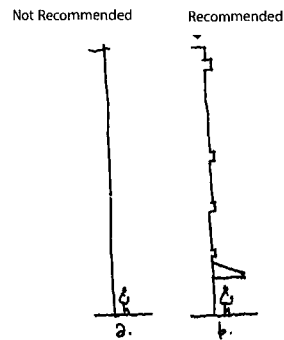

Fig. 57 Architectural Variety Creates Visual Interest

**Color and Materials:**

Consider materials that relate to surrounding existing buildings and the ballpark.

- Taller buildings should avoid dark tones thereby reinforcing the visual unity and special character of the City.

# F . P a r k i n g G u i d e l i n e s



## F. PARKING GUIDELINES

---

Parking guidelines are for parking facilities throughout the Plan Area, including integrated and free-standing structures. It is anticipated that a most all of the parking will be provided above grade. The guidelines are directed at ensuring that parking facilities are well integrated into the scale and character of Mission Bay neighborhoods.

**Residential Sidewalk Edge:**

Parking for residential uses may be buffered at grade by street-oriented uses such as housing units with street access, retail uses, residential entrance lobbies and foyers, parking podium access stairs and elevators, common areas, community facilities, or landscaping.

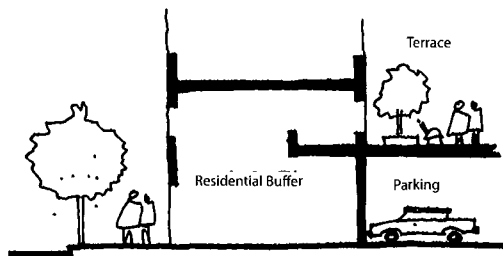

Fig. 58 Residential Buffer for Parking



- Parking frontage should be predominately an active use as described above.
- Where parking adjacent to the sidewalk cannot be avoided (e.g. where perimeter housing or retail are not feasible or desirable), the building base along the parking frontage should be designed with attention to detail compatible with adjacent buildings.
- Openings to parking areas other than garage doors should be limited to those required in the San Francisco Building Code for ventilation. Openings should be well above or below eye level and should be covered with visually attractive screening to minimize the parking and its lighting from being seen from the street.

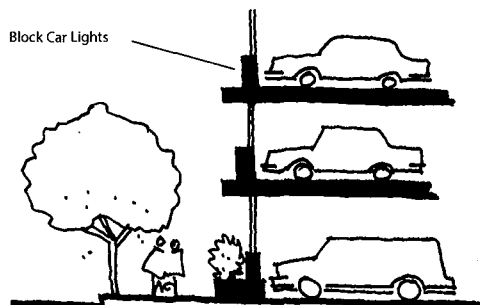

Fig. 59 Landscaping Buffer for Parking

- Residential garage entries should have doors that are visually opaque and attractively designed.
- Curb cuts should be spaced and arranged to maximize on-street parking and minimize sidewalk interruptions.

#### Commercial Industrial Sidewalk Edge:

Parking for commercial industrial uses may be buffered at grade by street oriented uses such as retail, building entrance lobbies, common areas such as cafeterias, business service uses, or landscaping with the objective of eliminating blank walls.

- Where parking adjacent to the sidewalk cannot be avoided (e.g. where entrance lobbies or retail are not feasible or desirable), the building base along the parking frontage should be designed with attention to detail compatible with adjacent buildings.
- Openings to parking areas other than garage doors should be limited to those required in the San Francisco Building Code for natural ventilation. Openings should be well above or below eye level and should be covered with visually attractive screening to minimize the parking and its lighting from being seen from the street.
- Curb cuts should be spaced and arranged to maximize on-street parking and minimize sidewalk interruptions.

#### Automobile Access to Parking:

Avoid breaking up the continuity of the retail frontage on streets throughout Mission Bay South. Access to parking for commercial and residential uses is discouraged on Third and Fourth Streets.

- Curb cuts should be spaced and arranged to maximize on-street parking and minimize sidewalk interruptions.
- On Third and Fourth Streets, south of 16th Street, a limited number of curb cuts for access to parking may be allowed.

**Pedestrian Access:**

Where feasible, the design of parking structures should promote the use of public sidewalks and mid-block connections for access to dwelling units from parking structures.

- Pathways and stairways linking parking structures to buildings (in addition to public walkway areas) should be interesting, well-lighted and secure.
- Landscaping, enriched paving materials and trellises can be used to improve the pedestrian experience.
- Access directly from parking to lobby or residential units should be avoided.



**Parking Podium Roofs:**

The roofs of residential parking podiums should be attractively finished in landscaping, walking surfaces, or recreational uses where feasible.

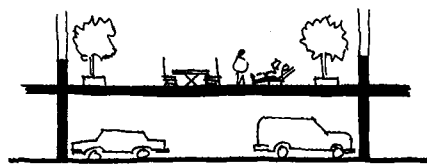
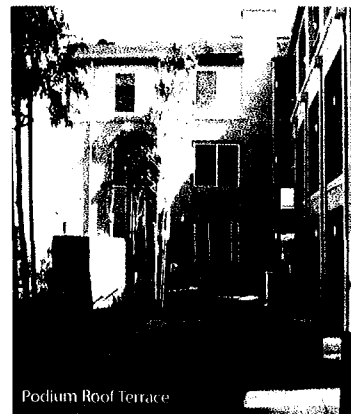

Fig. 60 Roof Terraces



### Street Frontage

#### Lighting:

Design lighting for vehicular and personal safety. Minimize dark areas, nooks, and other areas without clear sightlines.

- Light spillage from fixtures should be controlled to avoid conflicts with surrounding uses.
- Control impacts from vehicle headlights in parking garages on surrounding areas.

#### Entries:

Both on-site and street-side entries for vehicles and pedestrians should receive careful design treatment in keeping with the image quality they convey and the intense level of use they will receive.

- Stairs and elevator lobbies should be conveniently located, visually accessible from the building entry, well lit, and secure.



#### Shared Parking:

Parking structures are allowed in all areas. Parking structures should be designed with a similar degree of care as the buildings they serve.

- Where feasible, include active uses or landscaping such as retail on the ground floor of satellite parking structures.



## Architectural Character:

Parking garages should be compatible in color and materials with adjacent buildings and the development pattern in Mission Bay.

- For visual and security reasons, avoid solid wall surfaces at the street level where feasible. Where retail uses are not feasible, break up massing of large walls using design features such as changes of plane, textural changes, landscaping, and a visually pleasing pattern of solid and void.
- Setbacks from the property line are permitted to accommodate landscaping and other buffer features subject to design review. These features might include climbing vines, trellises, trees or similar landscape elements.



Fig. 61 Texture Solid Walls



## Loading Access:

Loading facilities (and outdoor refuse storage and dumpsters) should be located away from major pedestrian routes and intersections and shared with residential parking entrances where feasible.

- Entrances to loading facilities should be minimized in size and be designed with visual buffers, where feasible.

---

# G . S t r e e t   G u i d e l i n e s



**D** Key Streets

**4th Street:**

A neighborhood commercial street with consistent pedestrian-scale retail frontages and wider sidewalks, where feasible. The street should be designed as a bicycle and pedestrian connection through the area, including UCSF. Vehicular circulation south of Mariposa should be discouraged with traffic calming and other control devices that do not negatively impact pedestrian or bicycle connections.

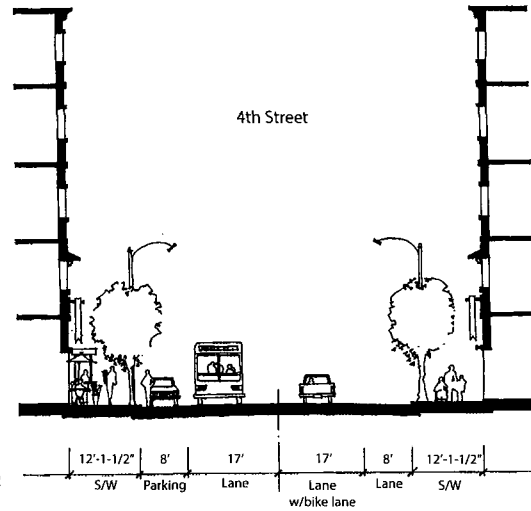

Fig. 62

**3rd Street:**

A mixed-use transit street with a strong urban definition marked by concentrations of taller buildings and active uses at key locations.

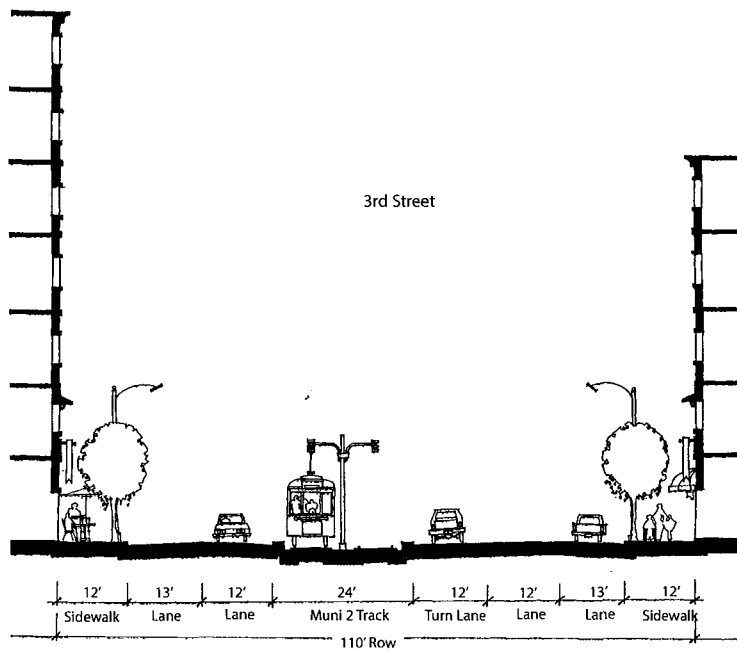

Fig. 63

Owens Street:

A boulevard street with landscaping and pedestrian paths, bikeways, adjacent and connected interior block open spaces, and an urban character defined by consistent building frontages and buildings. Owens Street will provide important access to the Commons and to the Seventh Street connector road.

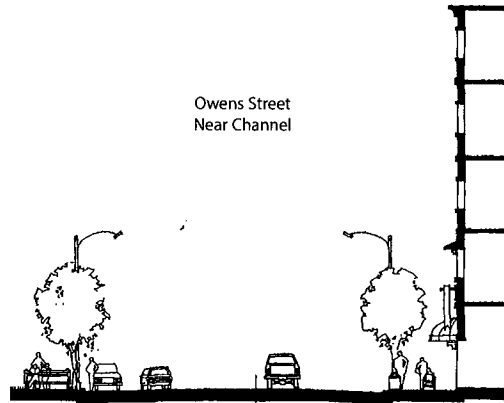

Fig. 64

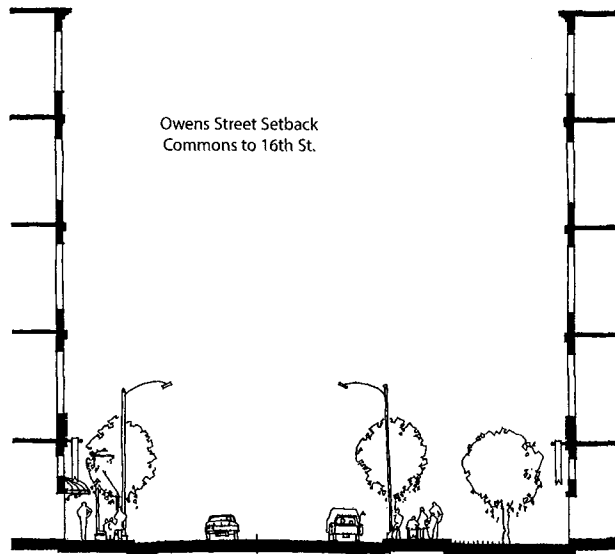
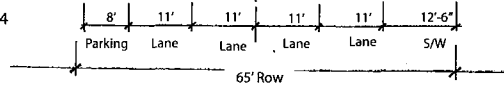
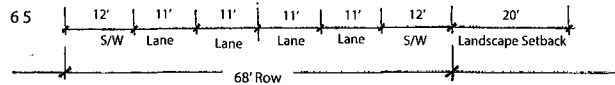

Fig. 65



Key Streets

16th Street:

An important landscaped street linking Mission Bay to Potrero Hill and other areas in the City. The street should be designed to reinforce this linkage with bike lanes, preservation of the view corridor, and a built urban edge.

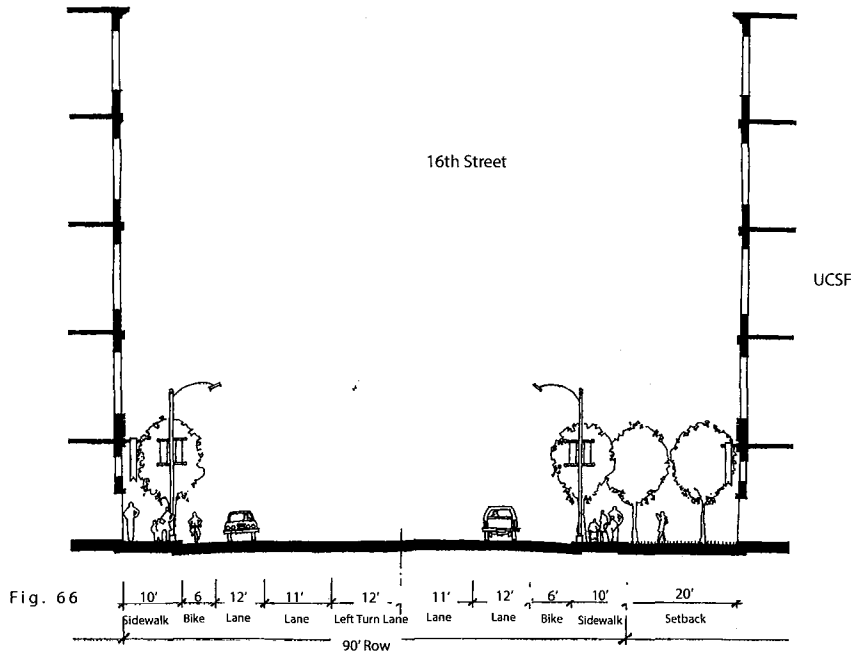

**Terry Francois Boulevard:**

A waterfront boulevard linking Mission Bay to the Bayfront Park and the Port properties and encouraging regional use by bicyclists and pedestrians.

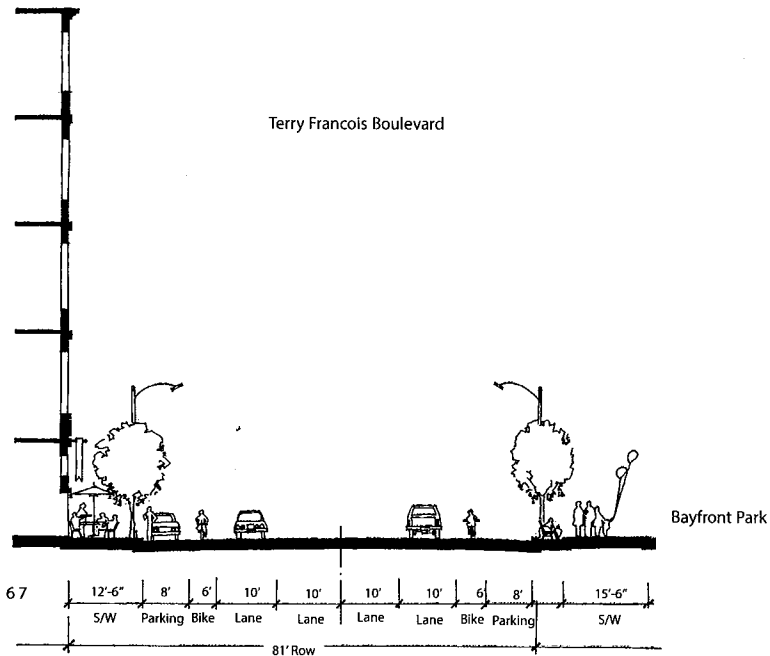

Fig. 67

**Mariposa Street:**

An important landscaped street between Potrero Hill and, Interstate 280 and the Bay. Includes pedestrian and bicycle paths.

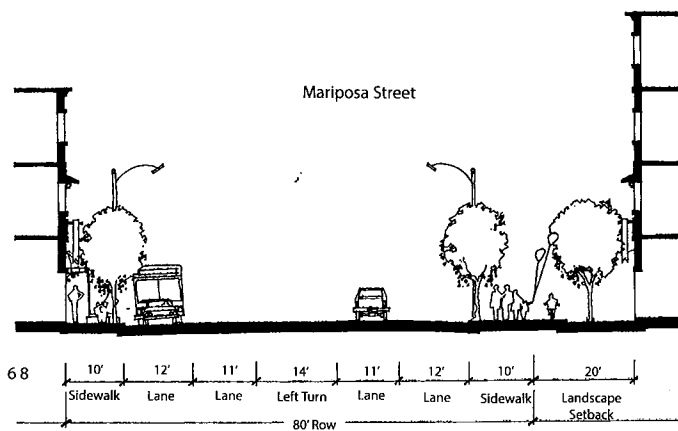
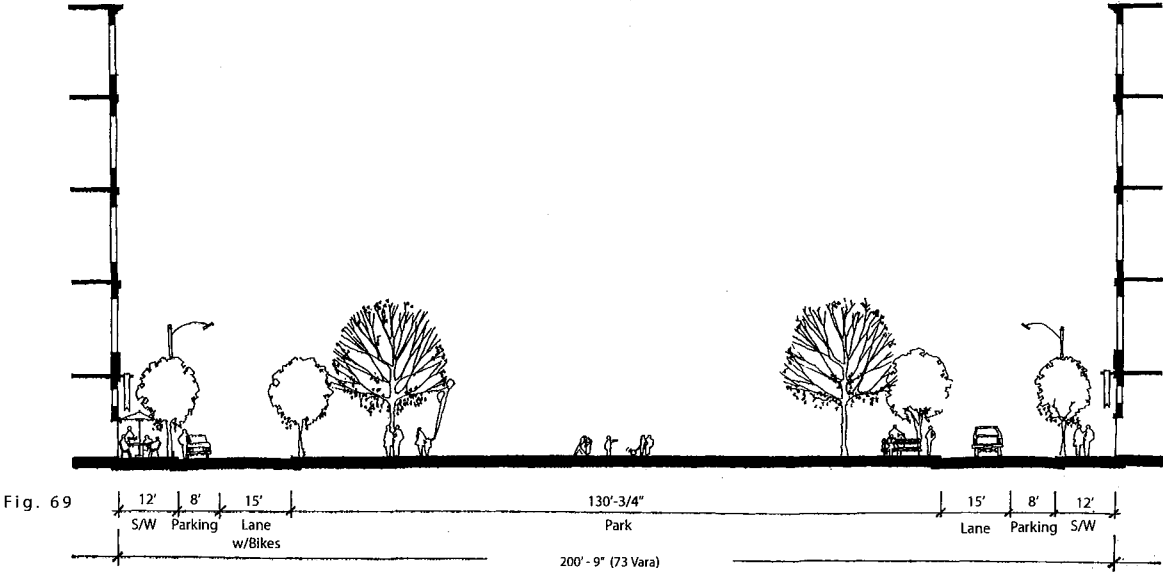

Fig. 68

Key Streets

**Mission Bay Boulevard:**  
 Elegant Urban Boulevard with narrow street areas and grand central open space connecting the Bay with points west.



**Neighborhood Streets**  
 Narrower, more intimate streets in residential areas with reduced vehicular traffic and lower building heights.

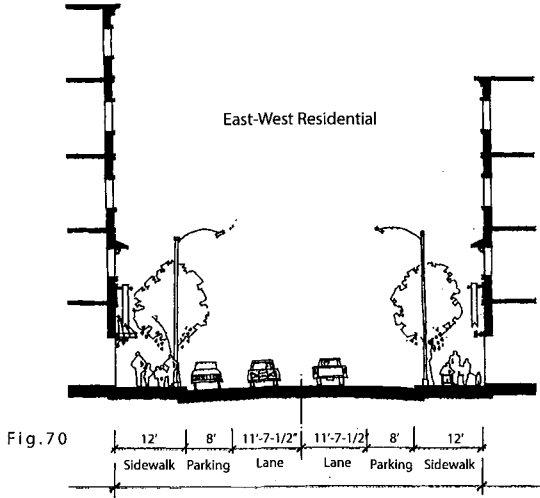

The design of the streetscape is an essential element that will determine the public character and pedestrian quality of the Mission Bay neighborhood. Streetscapes should be designed to create an attractive and pleasant walking environment, minimize pedestrian obstructions, promote pedestrian safety, and unify sidewalk details. The Agency may require the submission of a uniform streetscape program in connection with an owner participation agreement. Streetscape design will be reviewed by the Agency as part of the design review process.

### Sidewalk Furniture:

Seek to create a distinctive and consistent streetscape character for the Plan Area through the development of a cohesive design vocabulary for planting, paving, street furnishings, utilities, signage and lighting.

- Street furniture designs should address newsracks, trashcans, benches, light standards, utility covers, tree grates, kiosks, city bus shelters and bollards, as appropriate to special street character. Street furniture should be sited to ensure that a minimum of 6' clear through path of travel exists on the sidewalk at all times.

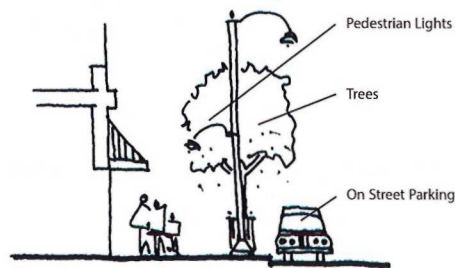

Fig. 71 Sidewalk Section

- Sidewalk cafes, planters, benches, public art and other pedestrian-oriented details installed by individual property owners are encouraged within the guidelines established by the Department of Public Works.
- Sidewalk utility boxes, such as transformer vaults, should be placed underground integrated into building walls, or integrated into the overall street furniture program. Free-standing utility boxes, independent of the comprehensive Mission Bay Street Infrastructure Plan are not permitted. **Above-ground media boxes within the 16th Street sidewalk frontage of Blocks 29-32 shall be permitted, subject to obtaining City-required minor encroachment permits.**

**Corner Widening on Residential Streets:**

Wherever appropriate, sidewalks should be widened at corners to provide more space for pedestrians and reduce the crosswalk distance.

- Consistent with the Mission Bay South Infrastructure Plan, corner widenings are especially encouraged on the residential neighborhood streets as a means of creating slower, safer streets, and providing more landscaped public space for the community.

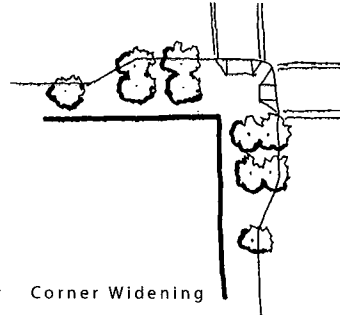

Fig. 72 Corner Widening

**On Street Parking:**

Parking is encouraged on Mission Bay streets, where appropriate, as a means of buffering pedestrians from vehicular traffic and for providing short term parking for adjacent retail and commercial uses.

**Lighting:**

Appropriate lighting is essential for maintaining pedestrian safety throughout Mission Bay.

- Pedestrian-oriented lighting attachments are encouraged on all lighting standards, especially residential and retail streets..
- Property owners should install sidewalk lighting as appropriate, consistent with overall streetscape design.

## Horticulture:

Tree species should be selected which will perform well within the specific environmental conditions of each parcel including, but not limited to, wind exposure, soil and sub-surface drainage and solar orientation.

- Provide planting pockets with sufficient space and depth for the root ball (typically twice the size of the root ball). Backfill planting pockets with a good, horticultural quality soil.
- Ensure appropriate irrigation and underdrainage for each street tree.

## Design:

Locate street trees at consistent intervals and at adequate spacing which responsibly address the issues of site context including, but not limited to, the dimensions of the roadway and parking lanes, the width of the sidewalk, and the heights of adjacent buildings.

- Consider and reflect the physical characteristics and growth habit of the tree species selected. It is recommended that trees be selected and maintained so that at maturity, they will be a dominant feature in the streetscape.
- Locate trees away from buildings to allow for full canopy development. Space and protect trees as necessary to prevent damage from parking cars. Investigate locating trees in the parking lanes by creating a widened sidewalk or using bollards.
- Street trees should be generally no further apart than 30', nor closer than 20' on center.
- Develop spatial continuity, define character and establish a locational identity for each street. It is recommended that one tree species be selected for planting along each street, thereby affording a visual identity and spatial coherence to each street.
- Recognize that planting of adjacent parks or open spaces may impact the configuration of street tree planting.

## Infrastructure:

Placements of utilities shall be coordinated with proposed configurations and spacing of street trees to minimize any detrimental effects on street trees.

- Utility lines and conduits should be placed sufficiently inboard towards the street from the centerline of the trunks of trees.
- Lateral utility lines and conduits should be placed sufficiently distant from the centerline of the trunks of street trees.





# V. C A C Design Objectives

The general objectives listing below were developed by the Mission Bay Citizens' Advisory Committee (CAC). These objectives were considered in the preparation of these Design Standards, the Redevelopment Plan objectives and policies, and in other documentation pertaining to the Project Area. They have been incorporated into the Design Standards to the extent feasible and are listed here for background and informational purposes only. Note that the entire list of objectives for Mission Bay are included here for reference but some may be applicable only to Mission Bay North.

### Urban Design Vision

1. Work to create a design of merit, in the context of distinctive San Francisco neighborhoods, and as a national and international model for excellence. Respect and acknowledge San Francisco's unique architectural styles, history and standards. Create a distinctive neighborhood which reflects the natural and historic character of Mission Bay and forms a gateway experience into San Francisco.
2. Acknowledge the Giant's Stadium as a key neighbor - in terms of its level of activity, scale and architectural character.
3. Sensitively integrate height and bulk while respecting and maintaining a pedestrian scale at street level where appropriate.
4. Enhance the view potential to the City, Mission Creek and the Bay.
5. Incorporate design transitions (scale, character, physical and/or visual linkages) that interface with other nearby residential neighborhoods including transitions to single family residences on Potrero Hill, South Beach, the park along the creek and the Lefty O'Doul bridge.
6. Establish an urban fabric of buildings and spaces that respects Mission Creek and the Bay, considering sun exposure and wind characteristics. Work to establish a human scale along the creek.
7. Provide varying building heights generally transitioning to a lower scale adjacent to the channel. In the South of Channel area, establish a similar transition of varying heights to a lower scale adjacent to the Bay.
8. Encourage Mixed-Use within Mission Bay, enhancing and supporting the quality of life for area residents, workers, and visitors alike.
9. Create a sense of place with clearly defined street hierarchy and character. Reinforce streets as defined public open space by establishing build-to-edge, setback and street section guidelines.
10. Design with consideration of existing and future major utility easements and storm overflow requirements.
11. Create a design that allows and encourages the integration of UCSF with the rest of Mission Bay.
12. Acknowledge the Port as a significant neighbor and potential future amenity. Integrate its planning with Mission Bay.
13. Establish an Urban Design Framework that provides a graceful transition between North and South of Channel neighborhoods.
14. Seek design opportunities for concentrated mixed-use development at transit stops which will enhance both development and transit potential.

---

## Transportation Infrastructure

1. Make Mission Bay a model San Francisco “Transit First” community, taking advantage of multi-modal transit opportunities, minimizing dependence on automobiles fostering a pedestrian environment, and working to avoid conflicts between different modes of transportation. Make real, attractive linkages to CalTrain, Muni light rail and bus service, a pedestrian and bicycle access network and potential water transportation services.
2. Address the physical and visual barriers created by infrastructure impediments. Consider elements such as linked uses (retail, residential, open space) that provide continuity through the neighborhood. Test whether there are locations that merit elevated access, to avoid barriers, ensure safety or to reinforce desired linkages.
3. Establish an efficient street network that allows for a seamless integration of Mission Bay with the existing city fabric.
4. Aesthetically integrate parking and automobile uses.
5. Provide usable, strategically located access linking north and south sides of the Channel.
6. Seek Muni light rail routing and stations that maximize service to Mission Bay.

## Open Space

1. Create substantial dynamic, people friendly public open space by considering the following:
  - variety of usable public open space
  - semi-public and private open spaces that enhance the public open space
  - enliven the open space by considering elements such as provision of occasional recreational water access and water uses
  - utilize public open space as a focus for residential and appropriate retail development
  - provide views of private open space, where possible
2. Make the Channel and the Bay key focal points of the development.
  - create destination open space and park areas, with a sense of invitation and comfort for a diversity of people.
  - undertake both north and south of channel as a coordinated design of varying widths and dimensions appropriate to the uses beyond mere circulation.
  - work towards a balance of active and passive areas
  - respect and enhance the natural environment and wildlife potential of the area, both in the location and scale of open space areas and selection of landscape and channel edge materials
  - design for families, children and older people
  - develop opportunity to provide a greater variety of water edge related uses
  - create zones of transition from soft edges to hard edges that integrate public access.
3. Create a public open space concept that allows for variety in scale and uses, along with visibility and accessibility from public streets and walkways.
4. Acknowledge the street and view corridor network as part of the overall open space concept, and promote public access through vehicular, bicycle, and pedestrian connections where practical.

### Livability and Constructibility

1. Create structurally efficient and cost effective designs.
2. Effectively integrate affordable housing sites into overall site plan.
3. Effectively integrate local serving retail, amenities, and open space throughout Mission Bay.
4. Address servicing requirements, and unique building features associated with R&D/ Biotech uses.

