

San Francisco, California

# Candlestick Point

---

Design for Development

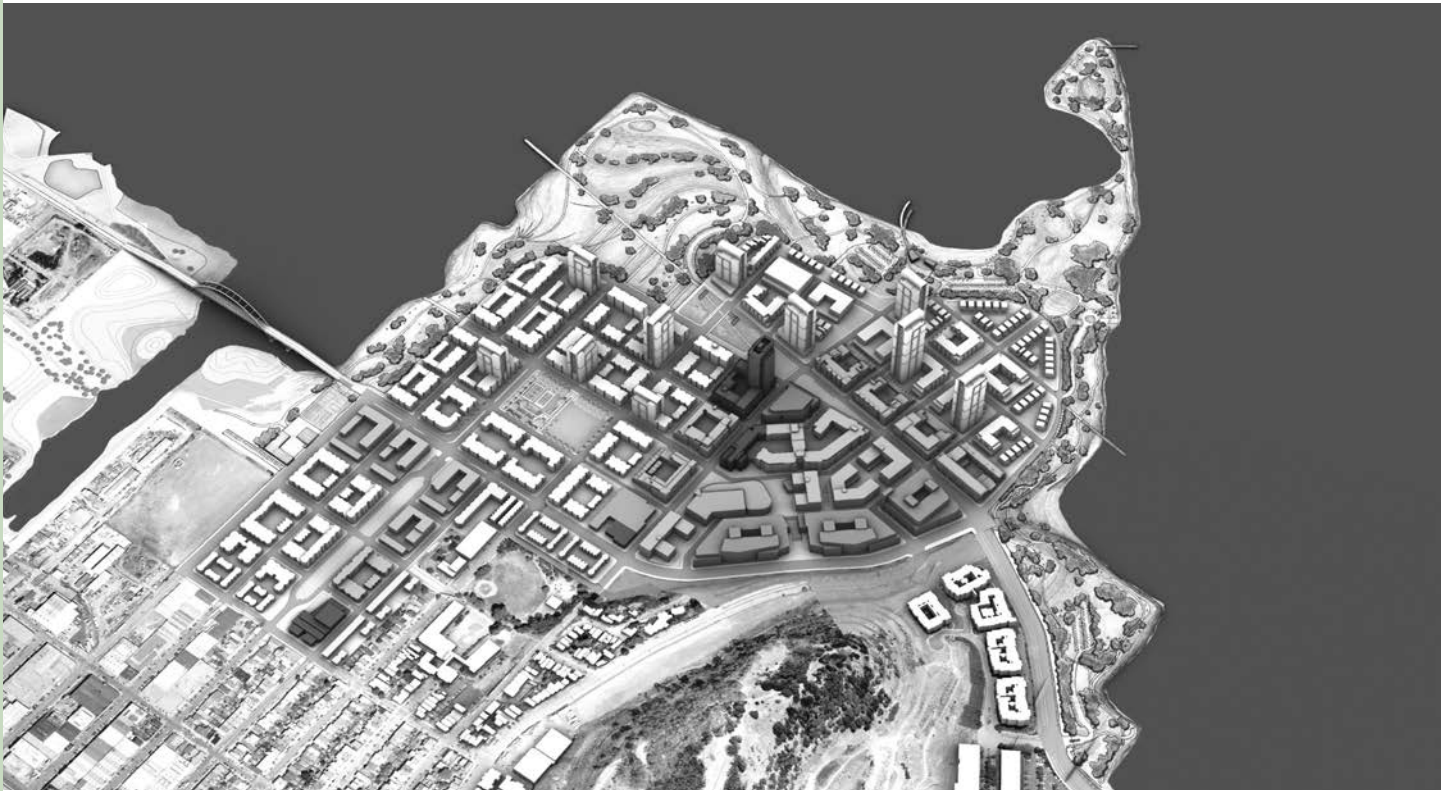





San Francisco, California

# Candlestick Point

---

Design for Development

Adopted June 3, 2010 by:

San Francisco Planning Commission Motion No. 18104

San Francisco Redevelopment Commission Resolution No. 65-2010

Amended by:

San Francisco Planning Commission Motion No. 19580 – March 3, 2016

Commission on Community Investment & Infrastructure Resolution No. 13-2016 – March 15, 2016

Amended by:

San Francisco Planning Commission Motion No. 20552 – October 24, 2019

Commission on Community Investment & Infrastructure Resolution No. 26-2019 – October 15, 2019



# Table of Contents

---

1.	Introduction.....	6
	1.1 Summary of Document	
	1.2 Background	
	1.3 Site Location and Context	
	1.4 Candlestick Access and Ownership	
2.	Vision .....	18
	2.1 Overall Concept	
	2.2 Goals and Objectives	
	2.3 Sustainability Design Principles	
3.	Proposed Plan for Candlestick .....	44
	3.1 Plan Structure and Program	
	3.2 Public Streets	
	3.3 Public Parks and Open Space	
4.	Land Use, Design Standards and Guidelines .....	74
	4.1 Land Use	
	4.2 Height, Bulk and Massing	
	4.3 Building Design	
	4.4 Signage	
	4.5 Parking and Loading	
	4.6 Streets	



5.	Neighborhood Standards and Guidelines.....	152
5.1	Alice Griffith	
5.2	Candlestick North	
5.3	Candlestick Center	
5.4	Candlestick South	
6.	Implementation .....	204
6.1	Design Review Process	
7.	Appendix.....	208
7.1	Appendix A – Term Definitions	
7.2	Appendix B – Block Plans	
7.3	Appendix C – Additional Studies	



# 1





# Introduction

- 1.1 Summary of Document
- 1.2 Background
- 1.3 Site Location and Context
- 1.4 Candlestick Access and Ownership

# 1 Introduction

---

## 1.1 Summary of Document

This Design for Development (D4D) document for Candlestick establishes the development standards and guidelines that will govern all future design and development at Candlestick. The D4D is the culmination of a multi-year community planning process. References throughout this document to the Shipyard are to Phase 2 of the Hunters Point Shipyard, the boundaries of which are shown in Figure 1.1.

On a macro-scale, the D4D is crafted to effectuate a specific urban form envisioned for Candlestick; on a finer scale, it outlines specific design regulations created to inspire attractive building architecture and functional public spaces as this new neighborhood comes to life over the coming decades. The Candlestick D4D document works in tandem with the D4D document for Phase 2 of the adjacent Hunters Point Shipyard Redevelopment Project Area. Taken together, the design regulations for both Project Areas aspire to fundamentally improve the built environment of Southeast San Francisco.

The Candlestick site lies within Zone 1 of the Bayview Hunters Point Redevelopment Project Area. The Bayview Hunters Point Redevelopment Plan (the BVHP Plan) has been amended to establish the allowable land uses for Candlestick. Thus, this Candlestick D4D is a companion document to, and authorized under, the BVHP Plan and was adopted by the Redevelopment Agency of the City and County of San Francisco (currently the Office of Community Investment & Infrastructure, successor to the San Francisco Redevelopment Agency), the public agency responsible for oversight of development within the BVHP Project Area. The BVHP Plan, in general, provides a vision for the area that eliminates blight and environmental deficiencies while supporting market rate and affordable housing, economic development, small businesses, emerging commercial-industrial sectors, public transit service, publicly accessible open space and participation by residents in deciding the future of the area.

The design standards and guidelines contained in this D4D apply to all development within the Candlestick site, including both the public and private realms, with the objective of implementing the vision set forth both in the BVHP Plan and in this D4D.

In 2018, the Board of Supervisors amended the BVHP Plan to exclude from the Candlestick Point project area that portion of land identified as the Jamestown Parcel, Assessors Blocks 4991 Lot 276. Figure 2.8 herein reflects the revised boundary for Candlestick Point excluding the Jamestown Parcel, and all figures in this D4D are deemed automatically amended notwithstanding boundaries shown on existing figures. Also in 2018, the Successor Agency Commission and Planning Commission approved a revised Design for Development and related documents for the Hunters Point Shipyard portion of the Project (available at <https://sfocii.org/candlestick-point-hunters-point-shipyard-phase-2-project-documents>). Depictions of Hunters Point Shipyard in this Candlestick Point document are for illustrative purposes only and may not reflect the 2018 revisions.



### Companion Documents

The Candlestick D4D addresses land use, building design, open space and street design within Zone 1 of the BVHP Plan. The D4D should be used in conjunction with a series of other companion documents that have been approved for the Candlestick and Shipyard sites. These documents include:

- Bayview Hunters Point Redevelopment Plan,
- Infrastructure Plan,
- Transportation Plan,
- Streetscape Plan,
- Signage Master Plan,
- Parks, Open Space and Habitat Plan,
- Sustainability Plan, and
- Design Review and Document Approval Procedure (DRDAP).

Together, these documents supersede the San Francisco Planning Code in its entirety, except as otherwise provided for in the BVHP Plan.

Maximum floor space entitlement for the various land uses is outlined in the Candlestick Point & Hunters Point Shipyard Phase 2 (CPHPS2) Disposition & Development Agreement (as amended) and the CPHPS2 Final Environmental Impact Report (and associated Addendums).

### Organization

This document has nine sections as follows:

- 1. Introduction** – Provides a summary of the document, describes the general background to the Candlestick redevelopment, site location, context and current access and ownership.
- 2. Vision** – Presents the overall concept, community goals and objectives, urban design principles and sustainability principles for the project. These are described for both Candlestick and the Shipyard, since a consolidated plan has been prepared for these two areas to develop a mixed-use community with a connected street and transit network and a shared open space and trails system. The overall vision provides the context for the Candlestick development plan, which is described in Section 3. The design standards and guidelines that are specific to Candlestick are located in Sections 4 and 5.



3. **Proposed Plan** – Describes Candlestick’s plan structure and program in terms of land uses, urban form, development program, the street network, and the parks and open space system.
4. **Land Use, Design Standards and Guidelines** – Establishes the overall standards and guidelines that regulate the form and character of the development for elements that span across the Candlestick site. These include land use, height, bulk, massing, buildings, parking and loading, and streetscape. *Standards* are mandatory actions, generally described in absolute terms such as by measurement or location. *Guidelines* are encouraged actions, which if adhered to in spirit will result in projects that best fit the vision for the site.
5. **Neighborhood Standards and Guidelines** – There are four distinct neighborhoods within the Candlestick site: Alice Griffith, Candlestick North, Candlestick Center and Candlestick South. A unique physical character is envisioned for each neighborhood and thus specific standards and guidelines are set forth for achieving the desired characteristics of such elements as at-grade retail, tower locations, street walls, mid-block breaks, and more.
6. **Implementation** – Presents the required procedures for implementing development plans for the individual parcels, granting variances and amending this document.
7. **Appendices** – Including term definitions, block plans, and case studies.

The user of this D4D should be conscientious in cross-referencing sections of this D4D in cases where a design standard may be described in more than one section. As organized, Section 4 provides design standards and guidelines universally applied throughout Candlestick, while Section 5 will often provide more detailed or rigorous standards pertaining to a particular neighborhood within Candlestick. For example, Candlestick site Street Wall requirements are contained in Section 4.2.4. However, more specific Street Wall requirements are proscribed in Section 5.2.2 for Candlestick North. In summary, users should read and understand the D4D in its entirety before proceeding with design and related analyses of a particular parcel’s development potential.

---

## 1.2 Background

The Candlestick and Shipyard areas along the Bayview waterfront total 702 acres of land in the southeast portion of San Francisco. Redevelopment of these two areas, which are largely underdeveloped and separated from the urban grid of the city, represents a rare opportunity to create an entirely new shoreline community within the Bayview Hunters Point community featuring: waterfront parks, a number of distinctive residential neighborhoods and a much needed injection of commercial and retail uses.

The combined project areas include: the Candlestick Point State Recreation Area; the site of a former NFL stadium owned by the City and County and former home of the San Francisco 49ers; the Alice Griffith public housing development; and a decommissioned Naval Shipyard with dilapidated structures for ship repair, piers and drydocks, and storage and administrative spaces. A number of former Navy buildings are currently being used as artist studios and by light industrial tenants.

While Candlestick and the Shipyard are geographically distinct, their adjacency to one another has fostered a combined redevelopment planning effort resulting in a cohesive community plan. This plan establishes the vision for transforming this large land area from blight to new, thriving neighborhoods ringing San Francisco's southeastern waterfront.

Bayview residents have been long at work in establishing the overall vision and goals for revitalization for the Bayview Hunters Point area, which includes both of these sites. This work produced the 1969 Hunters Point Redevelopment Plan, the 1969 India Basin Industrial Park Redevelopment Plan, the 1995 South Bayshore Area Plan, the 1997 Hunters Point Shipyard Redevelopment Plan, and the 2006 Bayview Hunters Point Redevelopment Plan. The goals established in these plans include: the development of job creating uses; improvement of existing parks; and tangible physical and economic benefits for the Bayview Hunters Point community, a long underserved and physically isolated part of San Francisco. Now the City and the Bayview community have been afforded a unique chance to implement many of these goals. Hence, an integrated plan has been prepared working with resident committees and with a developer partner.





Candlestick – State Recreation Area in foreground, former stadium in mid-ground, Bayview Hill and Bayview neighborhood in background.



Candlestick – State Recreation Area at left, former stadium at center, Bayview Hill at right.





photo courtesy of Mark Defoe at heliphotos@mchsi.com

The Shipyard – Downtown San Francisco in background.



photo courtesy of Mark Defoe at heliphotos@mchsi.com

The Shipyard – Drydocks and piers in foreground, the Hunters Point Hilltop in background.

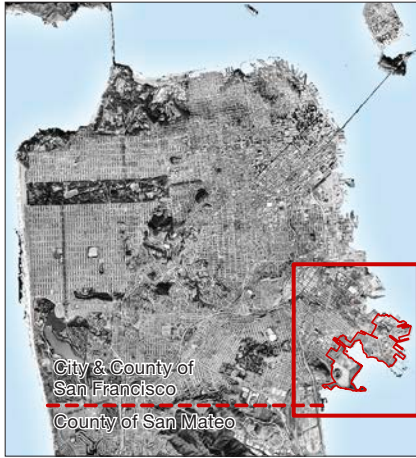

Site Location.

### 1.3 Site Location and Context

The Candlestick and Shipyard project sites are located approximately five miles south of downtown San Francisco in the southeastern part of the city. The total acreage of the two sites is approximately 702 acres, excluding the Yosemite Slough restoration lands. As indicated on Figure 1.1, both sites have extensive shoreline frontage along the San Francisco Bay to the east and south, the South Basin and Yosemite Slough watershed which separates them, and India Basin to the north of the Shipyard. Hunters Point Hill and Bayview/Hunters Point neighborhood sits to the west of the Shipyard site. Whereas the same neighborhood and Bayview Hill Park are adjacent to the north and west sides of the Candlestick Point site.

Bayview Hill Park creates a natural geographic limit to development and a buffer to Highway 101 to the west of the Candlestick site. This City park has trails which overlook the entire Candlestick site and provide panoramic views of the Bay. Part of Hunters Point Hill is currently being developed as both the Hilltop and Hillside Phase I developments of the Hunters Point Shipyard project. The southeastern portion of the Hunters Point Hill is being developed as a park, which will link into the proposed Shipyard Phase II development.

Candlestick was the location of the former Candlestick Park (the former stadium of the San Francisco 49ers NFL team), the Candlestick Park State Recreation Area (CPSRA) and the Alice Griffith public housing development. The Shipyard is a former U.S. Naval Shipyard, which was operational between World War II and 1974, and is currently accommodating some artist studios and light industrial uses on a portion of the site.

The Shipyard provided the major source of employment for the Bayview/Hunters Point neighborhood while it was operational. Subsequent to its closure, economic opportunity has declined in this part of the city as the site has remained largely unused since. Both the Candlestick and Shipyard projects will bring improved street and transit connections to the area, along with new employment uses that will substantially increase the community's economic activity.

To take advantage of this waterfront location, which provides the potential for some of the most significant open space area in the City, a major shoreline park will be created. New public connections to the waterfront will be provided. Further, a plan to restore the Yosemite Slough watershed, which feeds into the South Basin, will allow for an integrated park area to be created which extends from the CPSRA and includes the South Basin, Yosemite Slough and the southern shoreline of the Shipyard.



Figure 1.1 Site Context

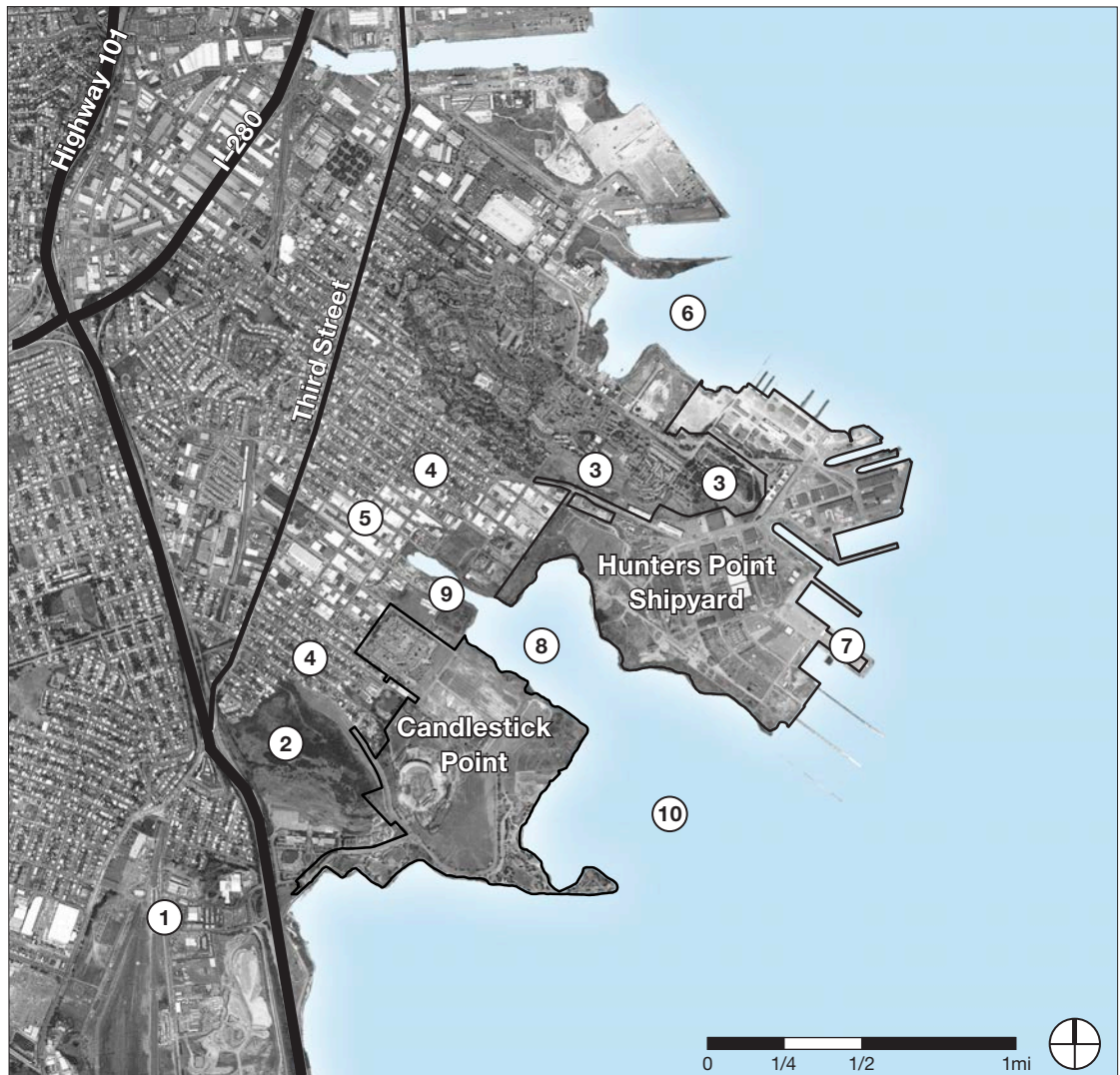

Legend

- ① Bayshore Caltrain Station
- ② Bayview Hill Park
- ③ Hunters Point Shipyard Phase I – Hilltop and Hillside
- ④ Bayview Neighborhood
- ⑤ Bayview Industrial Lands
- ⑥ India Basin
- ⑦ Re-gunning Crane
- ⑧ South Basin
- ⑨ Yosemite Slough Watershed
- ⑩ San Francisco Bay



State Recreation Area shoreline.



Alice Griffith housing.



Former Candlestick stadium.



Existing State Recreation Area.

**Legend**

- Improved State Recreation Area Lands
- Unimproved State Recreation Area Lands
- Yosemite Slough Restoration Site (outside development boundary)

## 1.4 Candlestick Access and Ownership

The Candlestick site is shown in Figure 1.2.

Access to the site occurs primarily from Harney Way, which connects with Highway 101 approximately one half mile to the west. Local streets in the Bayview neighborhood, including Jamestown Avenue, Gilman Avenue and Carroll Avenue, link the site with 3rd Street to the north.

Current land ownership is divided among several entities: California State Parks which oversees the Candlestick Point State Recreation Area (CPSRA); the City and County of San Francisco which oversees the former stadium site; the San Francisco Housing Authority (SFHA) which owns the Alice Griffith Housing site; and private property owners who own lands comprising the Jamestown parcel and several small parcels north of the former Stadium site.

At present there are three primary uses on the site. The CPSRA is used by local residents and regional visitors as a day use facility and is discussed further below. A former stadium site, including related surface parking lots, was the home for the San Francisco 49ers. The Alice Griffith site currently accommodates 256 residential units operated by the SFHA. The private parcels north of the former stadium site are used for an RV Park, and previously served as additional stadium parking.

### Candlestick Point State Recreation Area (CPSRA)

The State Recreation Area is the largest existing land use at Candlestick. It is unique in the California State Park system as the first park developed in an urban setting. Conceived in the late 1970’s, the goals of the park are to bring the values of the State Park system to the city, to provide recreational and cultural facilities and to connect urban dwellers with the natural environment.

The land that the park sits on was created by fill during the construction of former Candlestick Stadium. The State of California purchased the landfill site creating a major new park to enhance the quality of urban life and to promote care for the environment. The total acreage of the CPSRA within the project site is 121 acres.

The 1978 CPSRA Master Plan has never been fully realized. The southern portion of the park is the most developed and actively used area, while the northern areas are largely undeveloped and under utilized.

Primary recreation activities on the southern portion of the park include walking, biking, picnicking, windsurfing and fishing. Developed facilities include, parking, rest rooms, fishing piers, picnic areas, public art and a network of trails including the Bay Trail. Landscaping consists of large berms and trees providing shelter from the wind, open lawn areas and unirrigated grasslands.



Figure 1.2 Candlestick Access and Ownership



Legend

 Property Boundaries

# 2





# Vision

- 2.1 Overall Concept
- 2.2 Goals and Objectives
- 2.3 Sustainability Design Principles

## 2 Vision



Community park.



State Recreation Area.



Mixed-use streets.



Pedestrian plazas.

### 2.1 Overall Concept

The Shipyard and Candlestick will rejuvenate and integrate with the existing Bayview/Hunters Point neighborhood to create a vibrant mixed-use district that provides a major focal point to the shoreline area of southeast San Francisco.

Development will be compact, provide a mix of land uses and be oriented to the transit stops along the new bus rapid transit (BRT) line which will serve the area with frequent transit service. There will be market-rate and affordable homes, community services, regional and neighborhood commercial retail, research and development space (R&D), a hotel, a performance arena, and an expansive waterfront park system that extends along the entire shoreline of Candlestick and the Shipyard.

Identifiable neighborhood districts will be created that will each have distinctive characteristics. These neighborhoods will be woven together and to Bayview/Hunters Point by an open space network, pedestrian pathways and landscaped streets that connect to the existing Bayview/Hunters Point street grid. Thus, convenient access will be provided between the new neighborhoods, Bayview/Hunters Point and the waterfront park system. All development will be based on the principles of sustainable building.

The illustrative site plan that emerges from this vision is shown in Figure 2.1. The development program for the two sites will deliver 10,672 residential homes, retail space, office and R&D space, a hotel, performance venue, artists' studios, community facilities, and an expansive open space network. Maximum floor space entitlement for the various land uses is outlined in the CPHPS2 Disposition & Development Agreement (as amended) and the CPHPS2 Final Environmental Impact Report (and associated Addenda).

A detailed description of the Candlestick plan and program is provided in Section 3. The detailed plan and program for the Shipyard are found in the Hunters Point Shipyard D4D (under separate cover).



Homes near the State Recreation Area.



Figure 2.1 Illustrative Plan



Note: Refer to Figure 5.6 for Illustrative Plan of Candlestick Center.

---

## 2.2 Goals and Objectives

Nine goals and objectives have been identified to provide vision and direction for the overall concept for the Shipyard and Candlestick sites. The objectives relate to creating a series of mixed-use and transit oriented neighborhoods. These objectives should be viewed in the larger context of more specific land use and design standards and guidelines that are made for Candlestick in Sections 3, 4 and 5.

The development of compact, mixed-use neighborhoods drives many of the other development goals at the Shipyard and Candlestick – from the design of the transportation network, the amount and type of recreational and passive open space to be developed, to the location of compact residential sub-neighborhoods within both the Shipyard and Candlestick.

These objectives, which are discussed in the following pages, are:

1. Density Generates Vitality
2. Open Space and Natural Features
3. Street and Block Connectivity
4. Transportation Network
5. Pedestrian and Bicycle Network
6. Built Environment
7. Urban Placemaking
8. Character Neighborhoods
9. Retail Services





Candlestick mixed-use core including towers and mid-rise.



Mixed-use streets with neighborhood shops and services.



Street-facing retail uses.



Higher densities allow for related amenities like community parks.

## 1. Density Generates Vitality

The ultimate vision for Candlestick and the Shipyard is to develop a comprehensive community with a healthy balance of job and housing opportunities along with the accompanying local amenities such as retail shops, good transit service and open spaces, which includes the Bayview/Hunters Point neighborhood as part of that success. In order for this to happen, a critical mass of residents and jobs are needed to support the desired neighborhood amenities and create a lively appealing community.

The high residential densities proposed by the plan, ranging from approximately 15 to 285 units per acre, along with the significant amount of employment-generating space, will help achieve the critical mass to support the services planned for Candlestick and the Shipyard – public transit, an open space and recreation network, shopping and other community facilities – which are made feasible by virtue of a denser population center.

Equal in importance to sufficient density and a mix of land uses are the physical context and character of the neighborhood at build-out. The plan envisions a high quality environment in which people feel positive, easily oriented, safe and comfortable – where good urban design allows for the required level of density to be achieved at a human scale.



Density of residential and services is clustered around transit stops.





Precedent – Community park.



Precedent – Plaza.



State Recreation Area.

## 2. Open Space and Natural Features

The plan area has exceptional geographic features that include both the hills and the waterfront vistas for which San Francisco is famous. Bayview Hill and Hunters Point Hill act as bookends framing the western edges of the two sites, which also feature an inland watershed area – the Yosemite Slough – which leads to the South Basin between Candlestick and the Shipyard. The San Francisco Bay surrounds the northern, eastern and southern edges of the plan area, offering the opportunity to introduce new and improved access to existing major public spaces along the entire shoreline from south to north.

The Shipyard and Candlestick plan proposes to enhance the shoreline, the existing Candlestick Point State Recreation Area and other features, notably along the Shipyard’s historic dry docks and its ancillary structures. A continuous series of open spaces are proposed along the shore. The plan will also extend the green space from the waterfront into the residential areas to form broad, wedge and rectangular shaped parks that introduce a strong sense of openness and connectivity to the Bay. Other open space linkages to the shore will be created with boulevards extending to the water from parks within inner neighborhoods.

Further description of the general character of the parks and open spaces is contained in Sections 3 through 5 of this document, while specific standards and guidelines are addressed in the companion report - ‘Parks, Open Space and Habitat Concept Plan’.



Parks and Open Space Illustrative Plan. Refer to Figure 5.6 for illustrative plan of Candlestick Center open spaces.

Figure 2.2 Parks and Open Space Network



**Legend**

**Project Area Parks & Open Space**

- Urban Parks
- Other Parks & Open Space
- Candlestick Point State Recreation Area
- Sports Fields, Waterfront Recreation & Education

**Parks & Open Space Outside Project Area**

- Urban Parks
- Other Parks and Open Space
- Candlestick Point State Recreation Area
- Sports Fields, Waterfront Recreation & Education
- Bay Trail
- Bay Water Trail

*Note: Refer to Section 5.3 (including Figure 5.6) for information regarding Candlestick Center.*





Existing Bayview grid will be extended.



Precedent – Bicycle lanes.



Precedent – Boulevard ‘Park’ Street.

### 3. Street and Block Connectivity

The Candlestick and Shipyard plan envisions a new community that will become an integral part of the city. This will be achieved, in large part, by the extension of the existing Bayview/Hunters Point neighborhood street grid pattern into the new development to achieve a strong physical connection between Candlestick and Hunters Point and the adjacent neighborhoods. The new street grid will allow for easy orientation and wayfinding and permit uninterrupted views from public thoroughfares to San Francisco Bay.

New streets will be extensions of the existing Bayview grid; streets will extend to the waterfront Candlestick Point State Recreation Area; paths will connect the streets to the waterfront; and the waterfront will have a new Bay Trail that completes the largest gap in this trail system. A critical element in the network is the connection of Candlestick and the Shipyard, which is achieved by means of a transit and pedestrian bridge over Yosemite Slough. These improvements are shown in Figure 2.3.

Bayview’s existing grid of streets will be extended into Candlestick notably on Jamestown, Ingerson, Gilman, Egbert and Carroll Avenues. The cul-de-sac streets in the Alice Griffith Housing parcels will be removed so that the grid may continue unobstructed south into Candlestick. Harney Way will also be extended into Candlestick. Within the development itself, blocks will be divided by mid-block breaks (pedestrian mews or vehicular laneways), further promoting connectivity and walkability. At the Shipyard, Innes Avenue will be linked to the grid in the Shipyard North neighborhood including Galvez Street, Robinson Avenue and Lockwood Street. In the west, Palou will be linked directly with Crisp, the main gateway street into the Shipyard. Also at the Shipyard, pedestrian trails provide additional connections between the project and HPS Phase I where steep topography precludes viable street connections.

Further description of the general character of the streets is provided in Section 3.2 of this document, while specific standards and guidelines are addressed in the companion Transportation Plan.





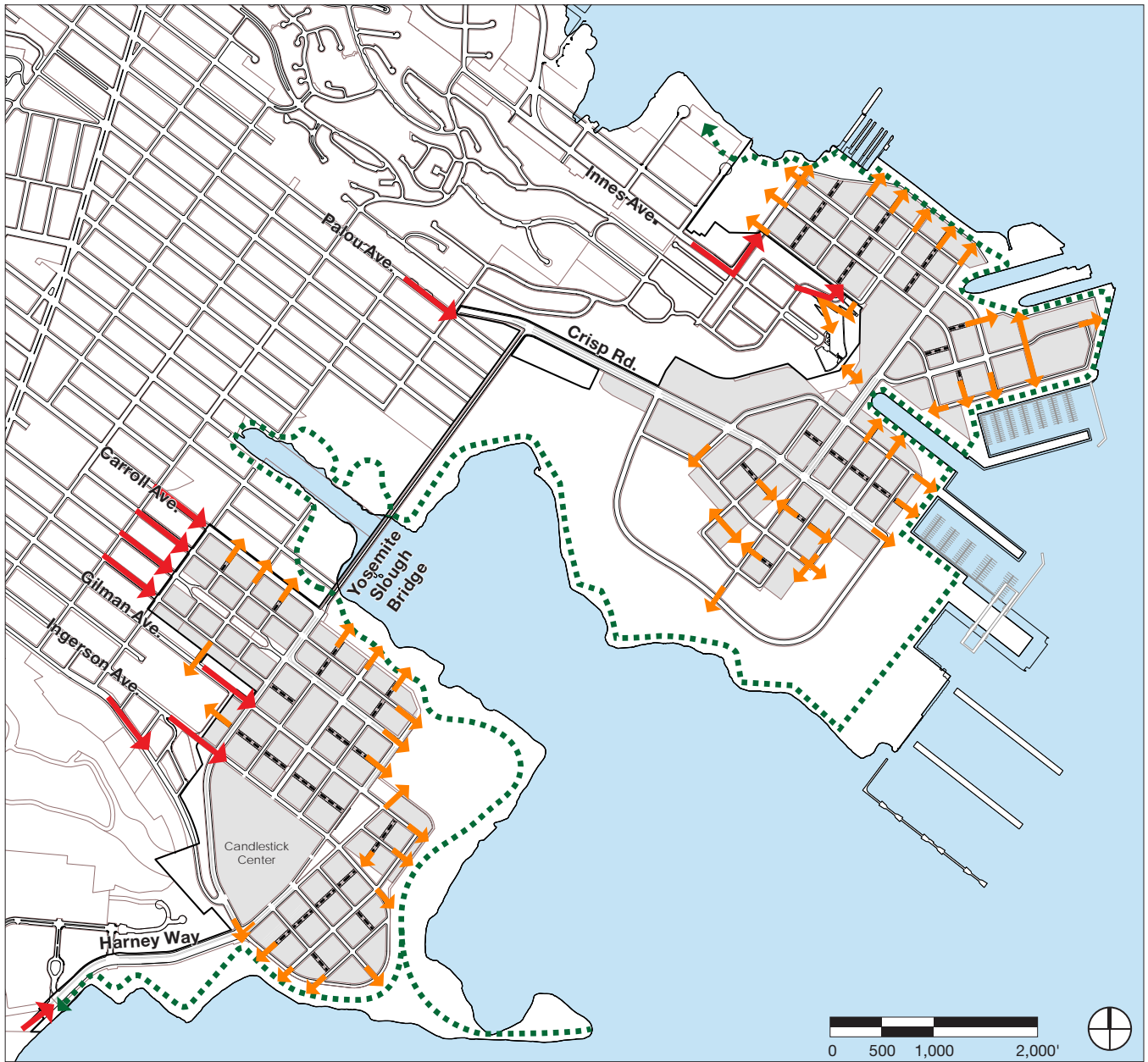

Connection of Bay Trail and Yosemite Slough Bridge (concept only – subject to detailed design).

Figure 2.3 Streets and Path Network



Legend

-  Pedestrian Access into Site
-  Pedestrian Access to Parks/Open Spaces
-  Pedestrian mews/ vehicular laneway
-  Bay Trail

*Note: Refer to Section 5.3 for information regarding Candlestick Center.*





Muni bus and BRT.



Precedent – Easily accessible transit stations.



Precedent – Mixed-use development clustered around transit stops.

## 4. Transportation Network

### General Discussion

A vastly improved transportation network, to include both thoroughfares and transit, is essential to successful development at Candlestick and the Shipyard.

The transportation strategy builds upon the MTA’s Transit Efficiency Project recommendations for the area, by adding robust new transit facilities. A new Bus Rapid Transit (BRT) system will have its own right-of-way through the community, enabling efficient and predictable travel between BART, Caltrain, the T-Third light rail, the Shipyard and Candlestick.

Transit stops that provide BRT service are located at key intersections in both the Shipyard and Candlestick. As shown in Figure 2.4 most new development will be located within a five-minute walk of BRT stops, in addition to more frequent stops throughout the neighborhood.

Non-BRT Muni buses also service both sites. Primary access to Candlestick is along Gilman Avenue, with stops throughout the center of the development. At the Shipyard, Muni service extends along Palou Avenue from the south, and Innes Avenue from the north. Both routes terminate in the core of the development.

The BRT stops will encourage transit oriented development (TOD), meaning a mix of land uses of medium to high density that is compact in form and oriented to the street. With this compact development pattern, most residents and employees will be able to walk to a stop from home or their place of employment – which can significantly reduce auto trips in the neighborhood. Further, compact development promotes land conservation, which in this case means that almost half of the site can be used as open space for common enjoyment. TOD leads to more urban and vibrant neighborhoods and promotes sustainable city building.

By concentrating a mix of uses with the five-minute walking radius of BRT stops, residents also benefit from convenient access to other important daily needs including jobs, shopping, restaurants and other community services.

Figure 2.4 BRT Route and 5 Minute Walking Radii

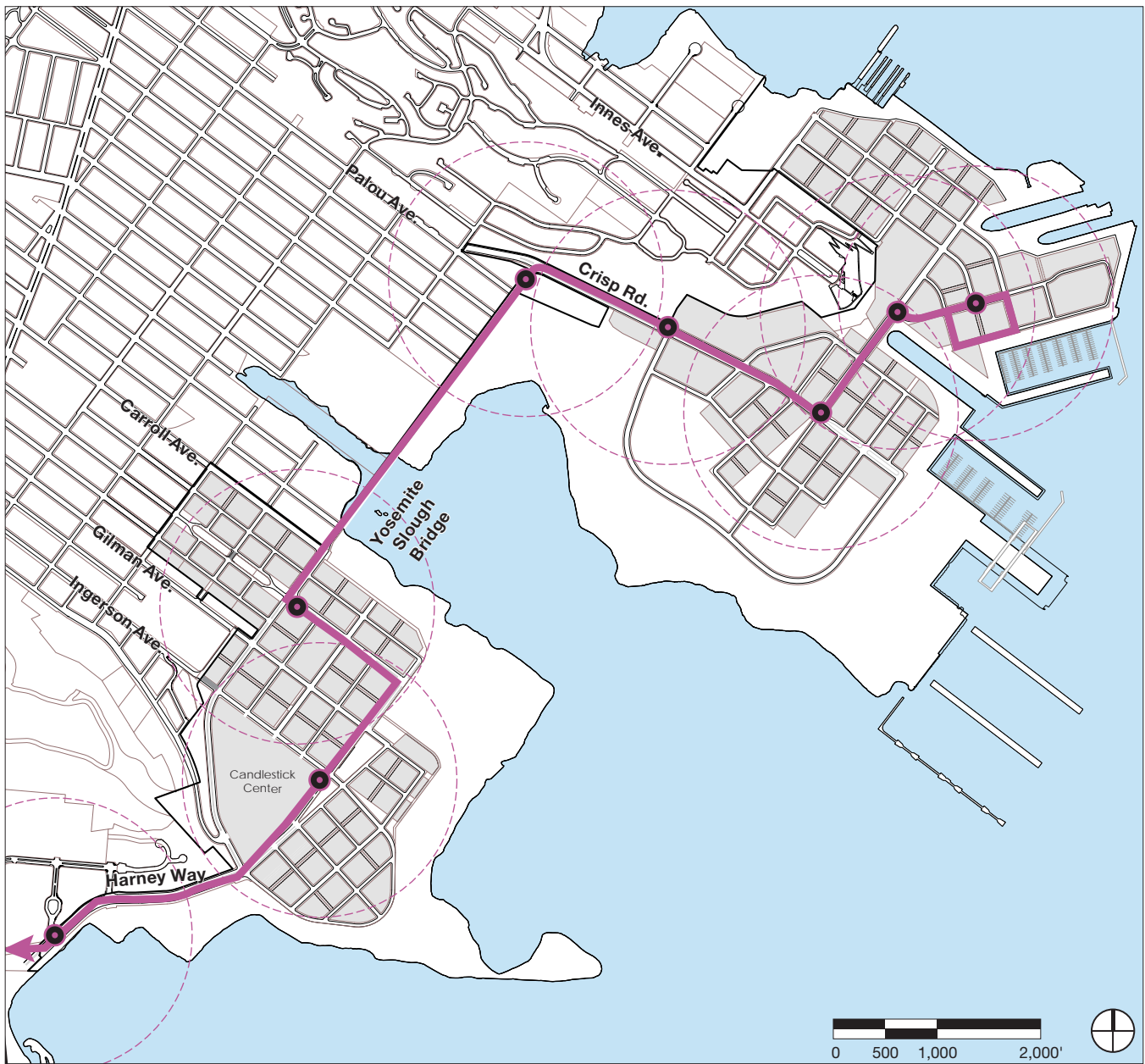

Legend

- Bus Rapid Transit Route
- Transit Stop
- 5 minute Walking Radius
- Development Area

Notes:

1. Refer to Section 5.3 for information regarding Candlestick Center.
2. Additional Bus Rapid Transit stops may be included in the final Candlestick Point Hunters Shipyard Phase II (CPHPS2) Transportation Plan for updated BRT stop information (available at <https://sfocii.org/candlestick-point-hunters-point-shipyard-phase-2-project-documents>).

### Yosemite Slough Bridge – Linking the Shipyard with Candlestick

A vital component to the transportation strategy is a convenient linkage between the Shipyard and Candlestick as a significant upgrade to the existing narrow and circuitous route around the Yosemite Slough. The Transportation Plan proposes to accomplish this by designating a right-of-way for transit, bicycles and pedestrians connecting the two destinations with an elegantly designed bridge across the Yosemite Slough.

The bridge would introduce a visible expression of the Shipyard and Candlestick’s interdependence and offer a direct non-automobile route to the two neighborhoods. The bridge’s design qualities, moreover, would become one of the community’s identifying features and enable people to enjoy the Yosemite Slough from a new, elevated vantage point.

The Transportation Plan proposes that the bridge be limited to pedestrians, recreation uses (such as fishing) and public transportation. The bridge will play a crucial role in providing efficient, predictable transit that respects and highlights Yosemite Slough as a wonderful ecological resource that defines and links the community’s two neighborhoods.

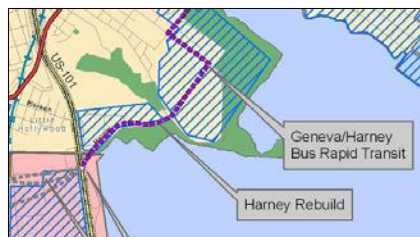

Location of Harney Way.

### Harney Way – Vital Transportation Link

Harney Way is the main transportation entrance to the existing Candlestick Park. It borders the Candlestick Point State Recreation Area located along the shoreline and is the principal access point to Executive Park, an office complex now emerging as a significant residential neighborhood. Yet the appearance of this roadway has never measured up to its prominence. Harney Way will serve as a vital transportation route both for Executive Park and for the major new shopping and housing development planned for Candlestick.

Harney Way will be rebuilt to accommodate automobiles, bicycles, pedestrians and the planned bus rapid transit (BRT) line. Moreover, it will be recast as a City boulevard with landscaping appropriate to a street bordering a waterfront park. Similar to the bridge proposed at Yosemite Slough, dedicated lanes for the BRT system will be a distinguishing feature. Harney Way’s auto lanes and BRT will be separated by a gracious, well-planted median strip.

Taken together, the BRT and median will constitute a desirable buffer between new development and the main roadways. The road will be built and designed as an attractive urban boulevard, providing a welcoming entry and gateway to the new Shipyard and Candlestick neighborhoods.



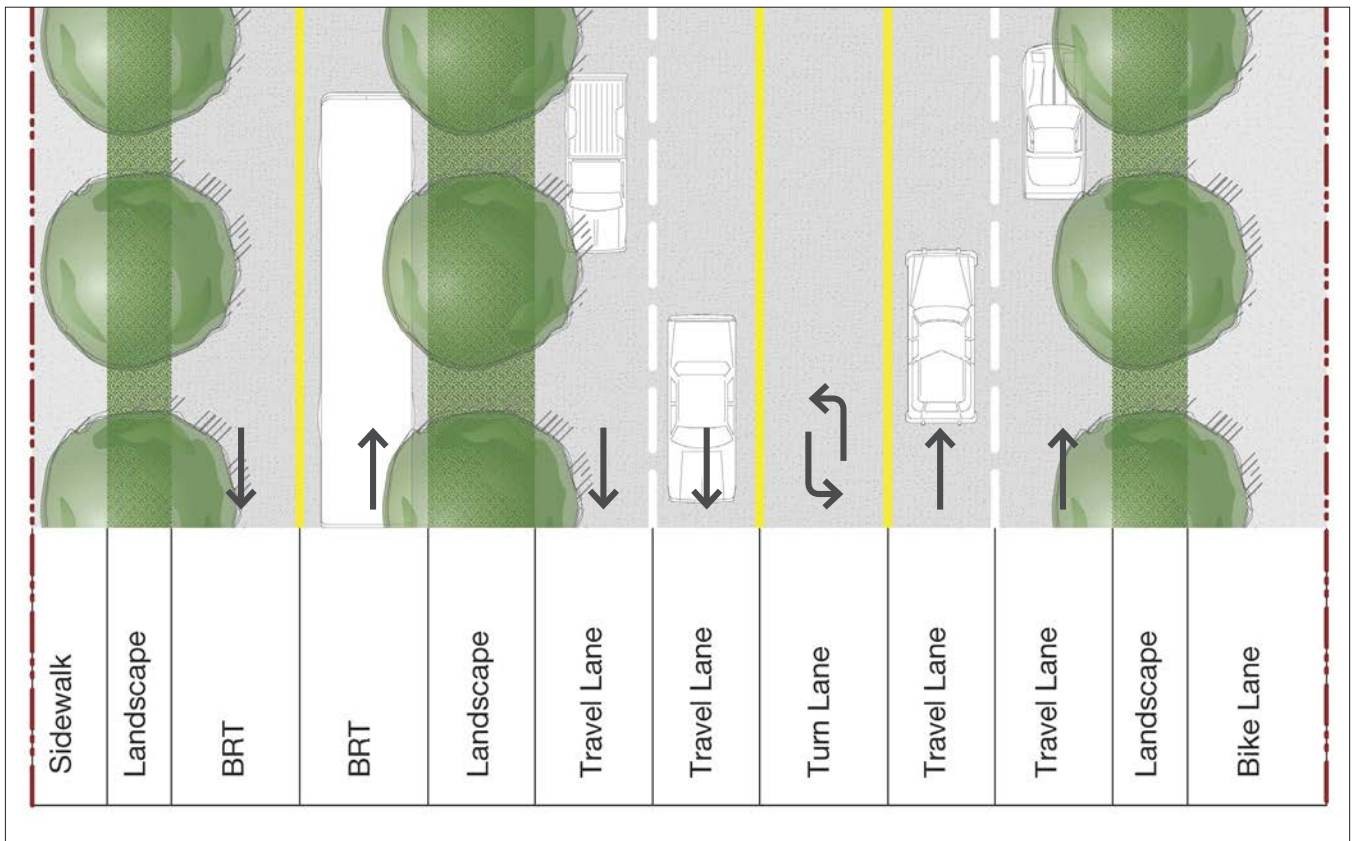
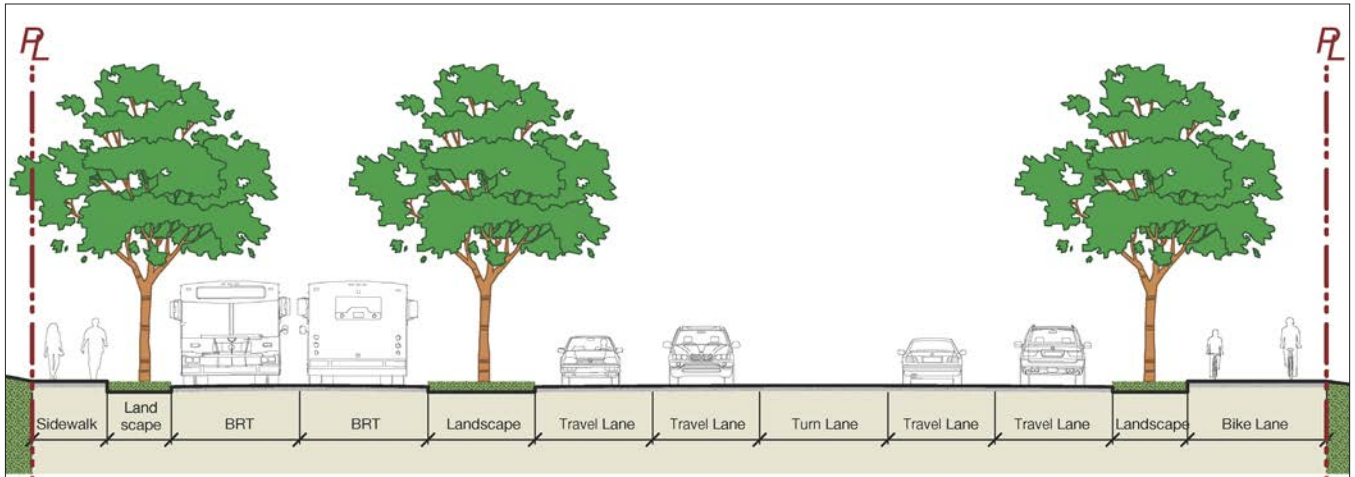

Harney Way with proposed BRT lanes, bike lane, pedestrian path, and boulevard median.



Precedent – Pedestrian trails.



Precedent – Generous sidewalks.



Precedent – Class 2 bicycle lanes on arterial and high traffic routes.



Precedent – Class 1 bike trails.

## 5. Pedestrian and Bicycle Friendly

### Pedestrian Network

Streetscape design focuses on pedestrian amenities to ensure that all residents can enjoy the streets with comfort and safety. Streets feature short block sizes, bulb-outs at intersections, slow and narrow traffic lanes, street trees, sidewalk plantings, lighting and benches. Boulevard Park Streets and Retail Streets provide additional interest and activities for pedestrians, while the park systems include miles of paths for strolling. Mid-block breaks with pedestrian access offer quiet, car-free walks connecting neighborhoods with each other and with the park system. Hillside walks connect to Phase I Hillpoint Park (Hillpoint Park) and enhanced streetscapes connect with the existing Bayview and the Shipyard neighborhoods. Off-site street improvements along Innes, Palou and Gilman Avenues will enhance pedestrian mobility throughout the Bayview neighborhood.

### Bicycle Network

The street network is designed to provide easy access for cyclists throughout the Candlestick and Shipyard sites with connections to the City’s existing and proposed bikeway network and destinations beyond. The San Francisco Bay trail forms a continuous off-street recreation route along the shoreline, connecting Candlestick and the Shipyard. Linkages between the Bay Trail and the development will be included in various locations to enhance access between the facilities. Additional off-street bicycle routes bordering the edges of the urban development and parks provide safe routes for cyclists of all abilities. Neighborhood streets are designed to emphasize slow auto speeds and encourage shared use of the street. Bicycle lanes follow arterial and high-traffic routes. These routes are shown in Figure 2.5. Bicycle racks are provided along the streetscape, with high concentrations near retail, parks, and transit stops.

Figure 2.5 Bicycle Network

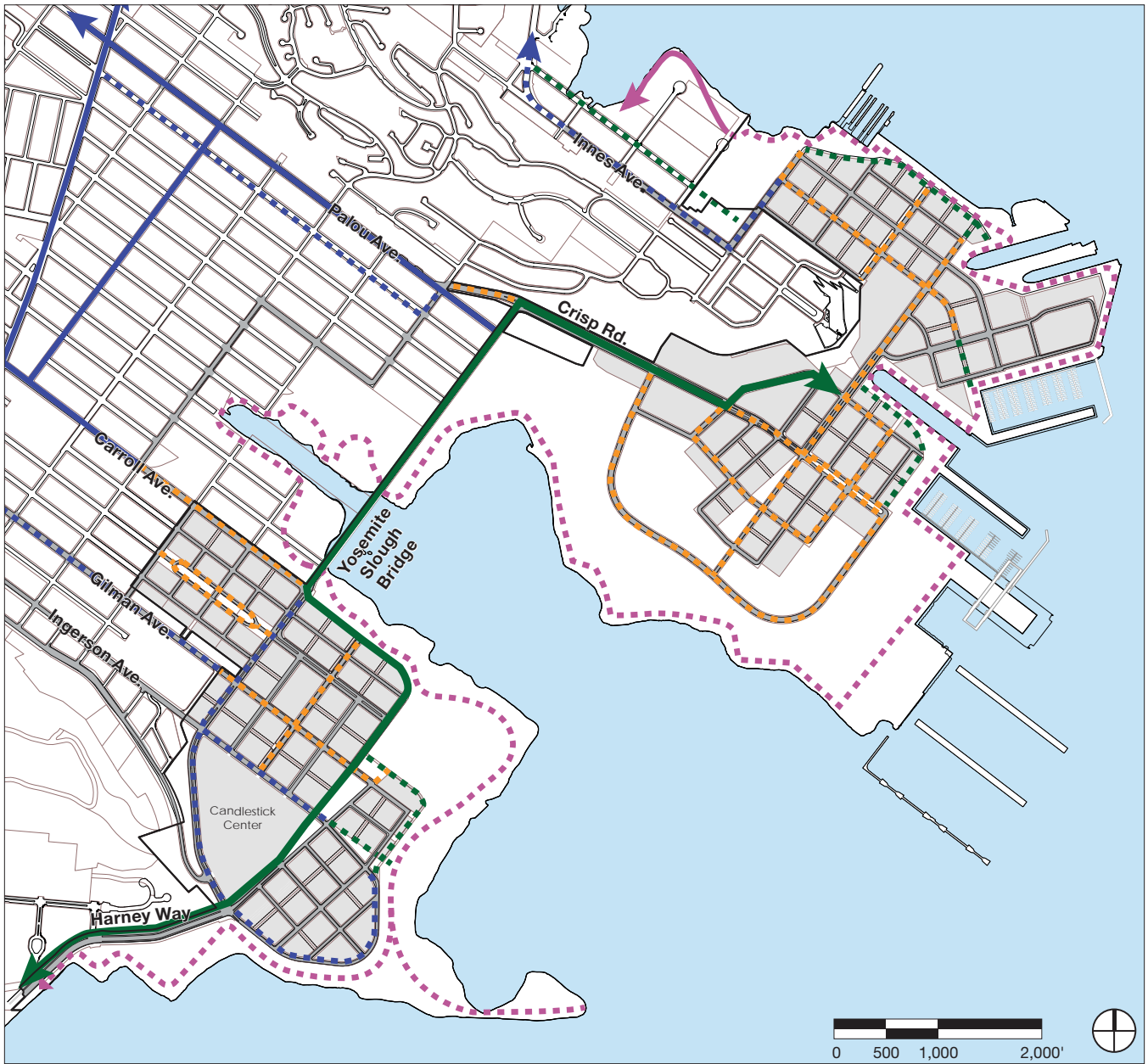

**Legend**

Proposed Routes

- Cycletrack
- - - Bike Class I
- - - Bike Class II
- - - Bike Class III
- - - Bay Trail/Blue Greenway

Existing Routes

- Bike Class III
- Bay Trail/Blue Greenway

*Note: Refer to Section 5.3 for information regarding Candlestick Center.*





Tower as focal point to public plaza.



Retail streets with continuous storefronts.



Residential Streets – street facing entrances and patios within a landscape setback.



Residences with setback for patio, landscaping and unit entrances.

## 6. The Built Environment

This D4D presents a compact urban environment that reflects the traditional growth patterns of many San Francisco neighborhoods, such as the Mission District, South of Market and North Beach. The development will have a unique identity with a sustainable, pedestrian friendly atmosphere resulting from building requirements that will promote active building frontages, attractively landscaped streets and setbacks, surrounded by a necklace of waterfront parks. Once a gated military base (Shipyards) and an under used State Park and former stadium site with vast surface parking (Candlestick), the area is planned to open up a vast new playground of outdoor activity, not only for new residents, but also for existing Bayview residents and all residents of San Francisco.

The overall vision places a high value on the public realm as this is the primary area where people experience the city and neighborhood. It is through the public realm elements – streets, sidewalks, building façades, adjacent small spaces, parks – that the neighborhoods derive much of their unique sense of place.

Streets will be more than just a means of mobility. Residential streets will feature landscaping and setbacks serving as a transition between the public and private realms. Street-facing patios, stoops, and primary and secondary entrances to ground floor homes will provide spaces for neighborly interaction while enhancing overall safety. Retail streets will be designed to have a continuous set of storefronts creating vibrant and animated streets, similar to many of San Francisco’s neighborhood shopping areas.

This D4D has been developed with careful attention given to the location and size of residential towers, in relation to smaller buildings. Towers are placed to create a unified urban form when viewed from a distance. Special care has been taken to adequately separate tall buildings to ensure that streets and open spaces are not overwhelmed, especially by shadows. By including dense building types such as towers in the mix of buildings, more land can be allocated to open space.

Both residential and commercial buildings will be subject to scrutiny as they proceed through the Agency’s design review process to ensure that they respect a human-scaled pedestrian environment and follow the standards and guidelines contained in this D4D.

Achieving an active, safe and engaging pedestrian experience is the objective for the design of building bases, whether the buildings are residential, retail or other uses. Rather than allowing the cold edifices of parking garages often found in new developments, an emphasis on multiple sidewalk-facing entries, maximizing windows, and opportunities for outdoor uses spilling onto the sidewalk are encouraged, and in many instances required.



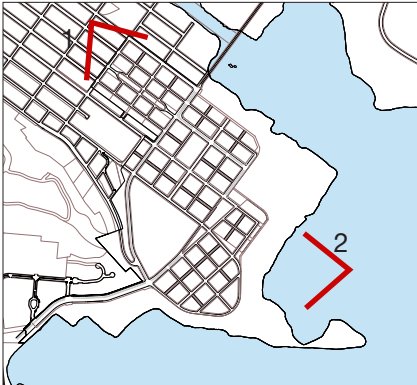

1. Candlestick looking southeast – Alice Griffith in foreground, Candlestick South and CPSRA in background.



2. Candlestick looking west – Lower and finer grained buildings near CPSRA.

*Note: Towers shown are one example of allowable tower locations (see Section 4.2.2 for details).*





Gateway locations reinforced by important buildings and public spaces.



Precedent – Focal Points located at important crossroads.



Landmark – Shipyard crane.



Precedent – Continuous streetwall edges to frame streets and parks.

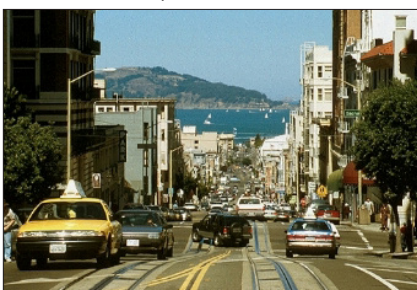

Precedent – Protect sightlines to the Bay.

## 7. Urban Placemaking

**Unique places will create identifiable character throughout the development.**

Development within the Candlestick and Shipyard sites will have visually exciting and memorable places that are linked to the site’s people, history and physical character.

Several elements provide the catalyst for creating unique and diverse places, including the strong influence and pull of the waterfront and the vast open spaces that surround the site, including the Bay, Candlestick Point State Recreation Area and the Bayview and Hunters Point Hills. These elements can be reinforced and woven into the fabric of the neighborhood through a number of urban design applications (see Figure 2.6).

### Gateways

Major entrances to the Candlestick and Shipyard sites, considered gateway locations, should be marked by significant architecture and public realm treatments to reinforce their importance. Entrances at the Shipyard include Innes, Palou and Crisp and a possible ferry terminal at the south end of Drydock 4. Entrances to Candlestick include Harney Way in the southwest and several Bayview streets to the west notably Carroll, Egbert and Gilman.

### Focal Points

Several important focal points occur at the intersections of key streets, pathways and open spaces. Accordingly, the buildings and civic spaces at these locations should be of significant scale and stature. Focal points at the Shipyard include the points where dense urban development meets the drydocks. At Candlestick the most significant is at the intersection of the two wedge-shaped parks and the two retail streets (Harney and Ingerson). This location marks the confluence of the parks, retail streets, and the center of the tallest buildings. Other secondary nodes that should be acknowledged are the main intersections along the retail streets and the BRT stops.

### Significant Features

Significant features should be reinforced by building or landscape landmarks. Significant features at the Shipyard include the re-gunning crane, the Hillside, the drydocks, and the piers. Significant features at Candlestick include the Candlestick Point State Recreation Area spit which itself is a visual terminus of Ingerson Street, and the corner of the Candlestick Point Center which marks the terminus of both wedge-shaped parks and Bayview Hill.

### Edges – Streetwall and Park

Continuous building streetwalls should frame all parks and streets in order to create ‘outdoor rooms’ for these public spaces. Wider spaces can have proportionally taller buildings. Edges between the community and the waterfront parks should be clearly delineated, either by continuous public paths or public roads.

### Sightlines and Viewsheds





Sightlines from the community to the Bay and other important landmarks should be maintained and reinforced. These include connections to the larger landscape: between the Shipyard and Candlestick and from the Shipyard to downtown. At the Shipyard, the viewshed from the top of Hillside Park (HPS Phase I) should be protected. Sightlines can be created with streets, lanes, pedestrian mews and parks.

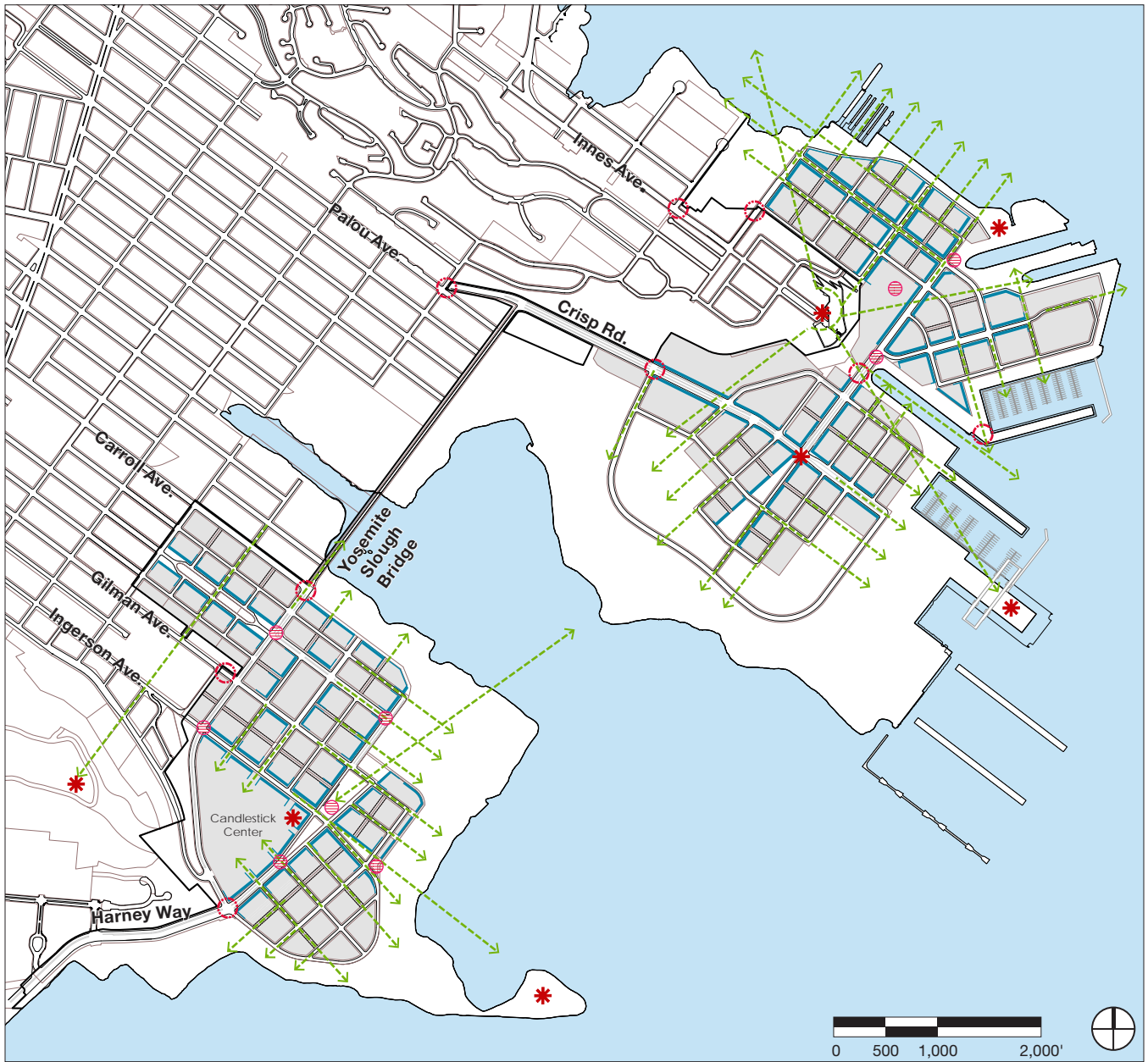

Figure 2.6 Urban Placemaking



Legend

-  Gateway
-  Focal Point
-  Significant Feature
-  Edge – Streetwall and Park
-  Sightline and Viewshed

Note: Refer to Section 5.3 (including Figure 5.6) for information regarding Candlestick Center.



Alice Griffith at Candlestick.



Candlestick Center.



Shipyard North.

## 8. Character Neighborhoods

**Neighborhoods will be defined by unique characteristics including identifiable parks, streets and building types.**

The Candlestick and Shipyard project area has nine character neighborhoods. Each will have a distinctive mix of uses, building typologies and public realm attributes with a broad range of amenities within close walking distances of homes and workplaces. Easily identifiable characteristics will be found in each neighborhood – which will have either a predominantly residential or a commercial/employment orientation.

Character neighborhood design principles are described below. Specific descriptions, standards and guidelines are found in the following locations:

- For Candlestick neighborhoods — Section 5 of this D4D;
- For the Shipyard neighborhoods — the Hunters Point Shipyard D4D under separate cover.

### Character Neighborhoods Design Principles

**Range of uses within close proximity** – Each character neighborhood contains a range of uses to enable daily activities to be accomplished within an easy walking distance from home or work. A mix of uses also contributes to a vital and flexible neighborhood, allowing a range of activities.

**Coherence** – Each character neighborhood will have coherence – an easily identifiable identity and sense of commonality. Identifiable local neighborhoods enable individuals to participate in community life and to maintain and improve their immediate surroundings by establishing a sense of ownership. Coherence can be achieved by the creation of distinct centers, edges and nodes.

**Scale** – To be understandable and manageable, character neighborhoods are limited in scale. The pedestrian shed, an approximate 5 to 10 minute walking distance, is a good guide. Character neighborhoods are sized to encourage community identification and management but still be large enough to encompass the variety of activities envisioned for these neighborhoods.

**Variety** – Each character neighborhood will have a variety of uses, spaces, housing types and tenures and workplaces. Character neighborhoods will not be defined by homogeneity but rather be interesting places with a fine-grained texture unified by well-defined common themes.

**Mix of Public and Private Space** – Each character neighborhood will be built up of both public spaces – parks, community spaces, and streets – and private spaces – homes, workplaces, and shops – providing places for both community and private life. The specific mix and makeup, and strategies for interfacing the private and public realms will be specific to the individual character neighborhood.

Figure 2.7 Character Neighborhoods

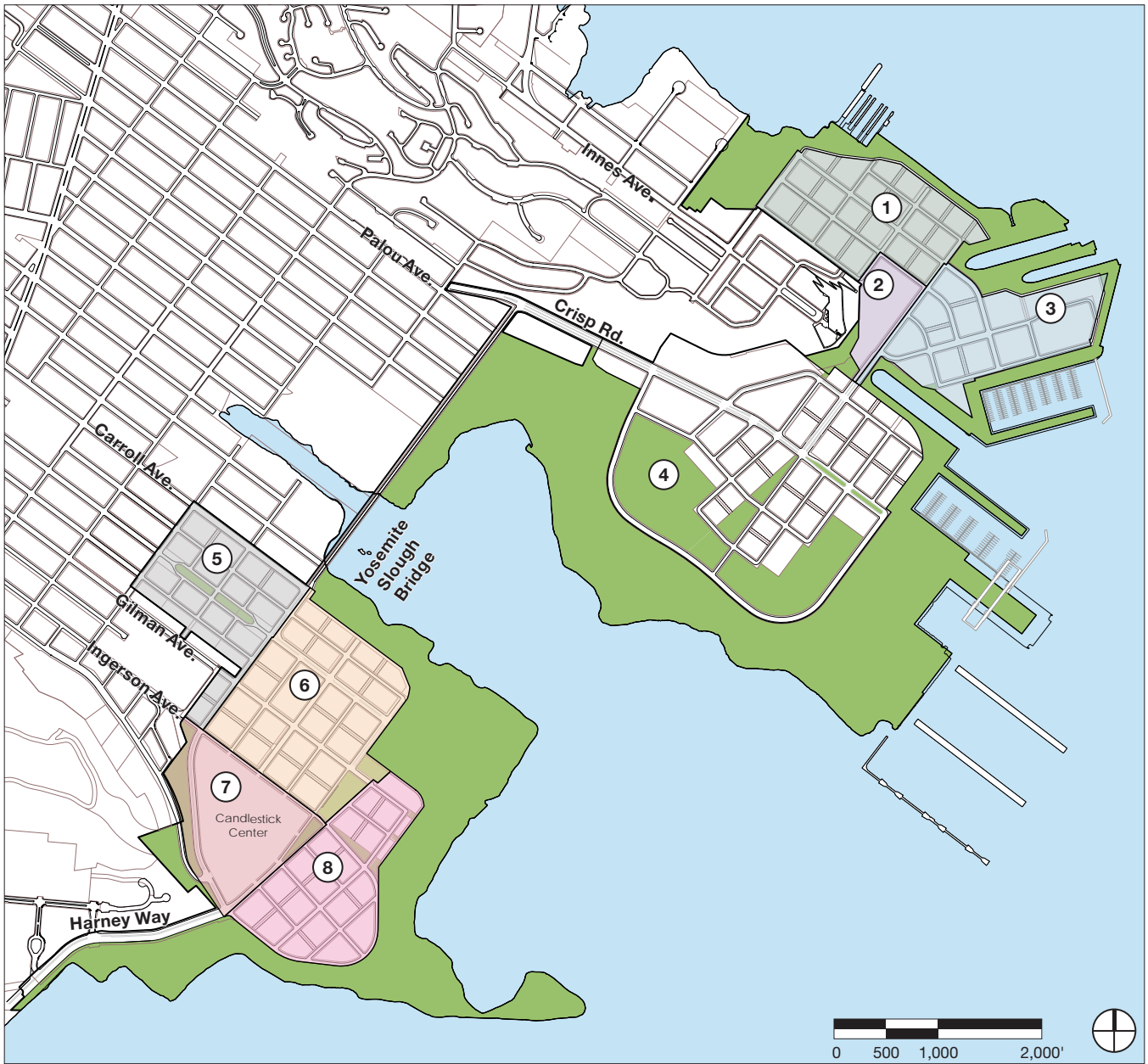

Legend

- |                            |                       |
|----------------------------|-----------------------|
| ① Shipyard North           | ⑥ Candlestick North   |
| ② Shipyard Village Center  | ⑦ Candlestick Center  |
| ③ Research and Development | ⑧ Candlestick South   |
| ④ Shipyard South           | Waterfront Open Space |
| ⑤ Alice Griffith           |                       |





Candlestick mixed-use streets.



Vibrant retail precinct.

## 9. Retail Services

The Bayview Hunters Point neighborhood has been served by only limited retail services on Third Street for decades. Now, with 10,672 residential units planned for Candlestick and the Shipyard (plus approximately 1,400 homes underway at the already approved Phase I of the Shipyard and another 2,800 units emerging at nearby Executive Park), a significant opportunity exists to fill this long-standing need. Thus a large mixed use center is planned in the Candlestick site. The center accomplishes four important objectives: 1) it meets a retail demand in the City’s southeast sector; 2) it helps to generate revenue needed in order to build the community’s infrastructure; 3) it offers many job opportunities for residents and; 4) it will become the town center for this extensive new community.

The Candlestick Center neighborhood, described in Section 5.3, is planned as a vibrant neighborhood with a lively mix of uses. Retail will line two pedestrian oriented main streets – Ingerson Avenue and Harney Way. Additional interior streets, walkways and plaza areas are proposed to emphasize the Center’s pedestrian nature. Housing, commercial, a hotel and entertainment uses are also planned in the neighborhood to reinforce the mixed-use character.

At the Shipyard, retail will be oriented to the neighborhood in a main street configuration on Fisher Avenue. It will have a unique overlay of character provided by the blending of artists studios that are planned for the area.



Candlestick’s mixed-uses at the corner of Ingerson Avenue and Harney Way.



Precedent – Native and regionally appropriate planting on the streets.



Precedent – Green architecture.



Precedent – Storm water management practices.



Precedent – Green roofs help mitigate storm water runoff.

## 2.3 Sustainability Design Principles

*Note: The general intent for the sustainability strategy is described below. For a more comprehensive description of the project's sustainability objectives, please consult the companion 'Sustainability Plan'.*

### Sustainability Plan Vision

The project's sustainability vision statement is the following:

*The Candlestick and Shipyard will be a neighborhood that is vital, accessible and integrated into the San Francisco Bay area. It will provide opportunities for residents to live, recreate, earn a living wage, obtain a good education, and raise a family in a safe, affordable and healthy environment.*

The Candlestick and Shipyard projects will be models of sustainable urban design that stimulates the local clean technology economy, and addresses global environmental challenges such as climate change, rising energy costs and increasing water scarcity.

A comprehensive sustainability strategy has been developed for Candlestick and the Shipyard to demonstrate how the project will provide the Bayview community with amenities that it has not historically enjoyed: opportunities for local jobs at all skill levels, local retail options, a safe walkable community, and a variety of parks and open spaces.

The sustainability strategy also describes measures that will minimize the impact of the development on local infrastructure, resources and the environment, and measures to preserve the unique culture and diversity that defines the area. Project sponsors will apply for and aspire to obtain a LEED-ND (Neighborhood Development) Gold certification for the entire Candlestick and Shipyard community.

A detailed Sustainability Plan has been prepared and is a companion document to this D4D. Its main points are summarized by the following seven sustainability focus areas.

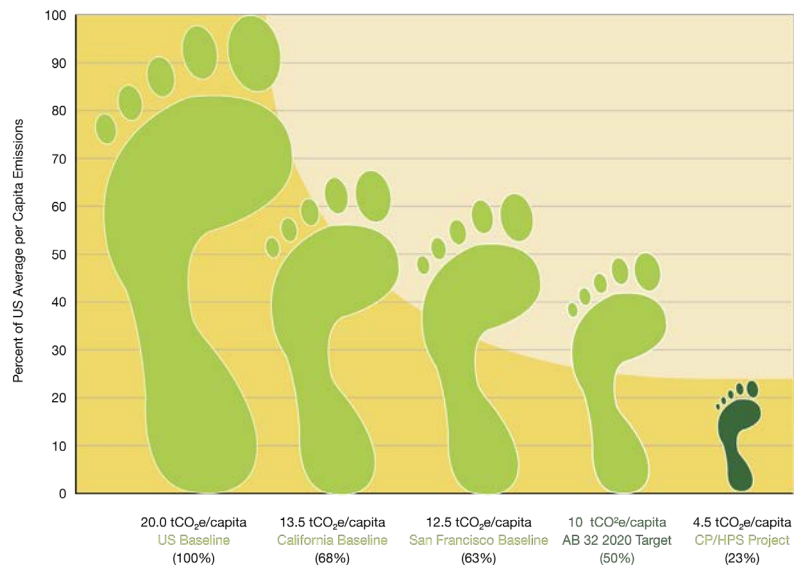





- ▼ Economic Vitality
- ▼ Resource Efficiency
- ▼ Community Identity and Cohesion
- ▼ The Environment
- ▼ Public Wellbeing and Quality of Life
- ▼ Accessibility and Transportation
- ▼ Advanced Information Communication Technology

### Sustainability Focus Areas

The following are seven focus areas for sustainability objectives at the Candlestick and Shipyard Projects.

1. **Economic Vitality and Affordability.** Enhance the competitiveness of the region and restore the vitality of the Bayview by fostering a vibrant local economy and supporting a mixed-income community.
2. **Community Identity and Cohesion.** Create a strong sense of community by integrating the new neighborhood with the rich culture and diverse history of the existing neighborhood.
3. **Public Well-Being and Quality of Life.** Provide a healthy and safe neighborhood with sufficient community facilities, parks, essential services and public spaces to engender a high quality of life for residents of all ages and abilities.
4. **Accessibility and Transportation.** Significantly improve accessibility to the site and reduce traffic impacts on the surrounding area; promote walking and cycling as the primary modes of transportation within the development.
5. **Resource Efficiency.** Implement a whole-systems approach to energy conservation efficiency and sustainable supply that minimizes the need for fossil fuels.
  - Significantly reduce greenhouse gas emissions by residents and businesses.
  - Provide an integrated urban water system that achieves maximum synergy between the three core water disciplines — potable water, wastewater, and storm water — and enables the community to live within its natural water budget.
  - Reduce, reuse and recycle appropriate solid waste materials, with a special emphasis on reusing construction materials and recycling organic wastes in an effort to divert waste from landfills.
6. **Environment and Habitat.** Protect and, wherever possible, enhance parks, natural habitats, soils, water bodies, air and climate.
7. **Utilize Advanced Information and Communications Technologies (ICT).** Integrate Information and Communications Technologies (ICT) such as smart grid and cellular broadband infrastructure into the development to allow residents to better manage energy and water resources, bolster local economic activity, improve access to real time information, and facilitate community communications and activity.



Figure 2.8 Revised Boundary Map

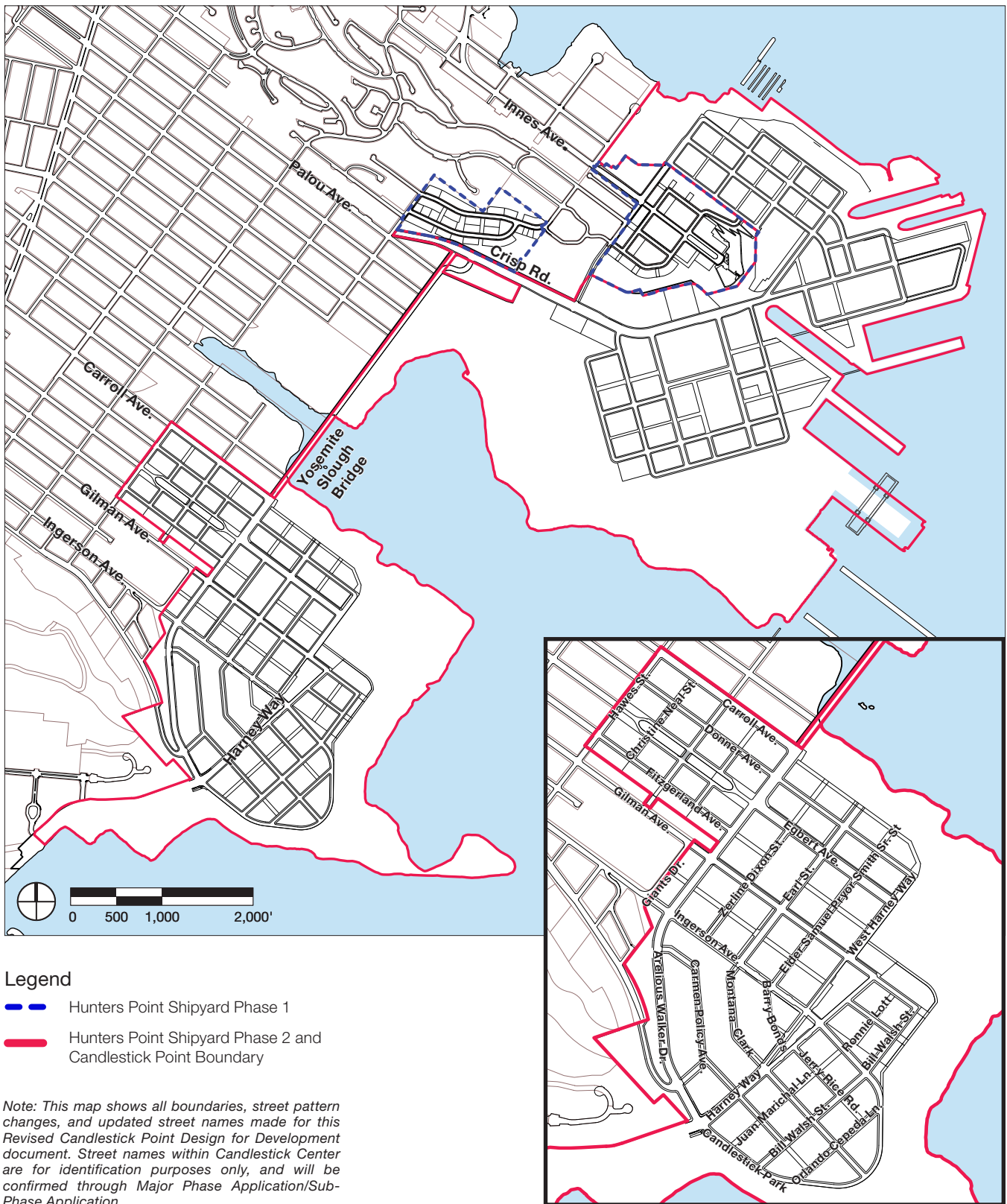

**Legend**

- — — Hunters Point Shipyard Phase 1
- — — Hunters Point Shipyard Phase 2 and Candlestick Point Boundary

*Note: This map shows all boundaries, street pattern changes, and updated street names made for this Revised Candlestick Point Design for Development document. Street names within Candlestick Center are for identification purposes only, and will be confirmed through Major Phase Application/Sub-Phase Application.*

Enlarged map of Candlestick Center.

# 3







# Proposed Plan for Candlestick

- 3.1 Plan Structure and Program
- 3.2 Public Streets
- 3.3 Public Parks and Open Space



## 3 Proposed Plan for Candlestick

---

### 3.1 Plan Structure and Program

#### Vision

The vision for the redevelopment of Candlestick, as shown in Figure 3.2, is for a compact, mixed-use community that rejuvenates and expands the existing Bayview neighborhood. This, in combination with planned development at the Shipyard, will create a significant new focal point for southeastern San Francisco.

Candlestick will be comprised of several unique neighborhoods, each characterized by local influences including the site's waterfront. The neighborhoods will be woven together and to the larger community by a large open space system comprised of parks, various greenways and trails, and a continuous waterfront park, part of which will be a refurbished Candlestick Point State Recreation Area.

#### Land Use

The BVHP Plan establishes Land Use Districts within Candlestick. Allowable land uses within each Land Use District are set forth in the BVHP Plan. The Land Use Districts established by the BVHP Plan are shown in Figure 4.2.

The proposed land uses at Candlestick Point include a substantial waterfront open space network, regional and neighborhood retail mixed-use buildings, hotel and entertainment facilities, residential housing in forms ranging from townhomes to high-rise buildings, and community uses. Maximum floor space entitlement for the various land uses is outlined in the CPHPS2 Disposition & Development Agreement (as amended) and the CPHPS2 Final Environmental Impact Report (and associated Addendums).

#### Urban Form





The overall urban form – the pattern of streets, blocks and open spaces – is configured in such a way as to link the center of the site to the shoreline's open space and views. The physical linkage is achieved by providing new, wedge-shaped parks that connect the waterfront Candlestick Point State Recreation Area to the center of the site, while the visual linkage is achieved through the perpendicular orientation of the streets to the shoreline.

The street and block pattern is an extension of the existing Bayview grid. It will be augmented by mid-block breaks (pedestrian mews and/or vehicular alleyways) in order to create a finer, pedestrian scale of blocks and buildings while increasing mobility and connectivity.

Figure 3.1 Urban Placemaking



Legend

-  Gateway
-  Focal Point
-  Significant Feature
-  Edge – Streetwall and Park
-  Sightline

*Note: Refer to Section 5.3 (including Figure 5.6) for information regarding Candlestick Center.*

Within blocks, building massing frames important streets and open spaces while protecting views and sunlight. Blocks with lower density building forms are located nearest the existing Bayview community as a transition between existing and new areas and near the waterfront areas. Higher density forms are located near important nodes at the center of the community.

Individual buildings are programmed and proportioned to enhance their legibility at the pedestrian level by way of clearly defined building bases that contain Active Uses. This includes an extensive setback zone for the provision of ground oriented patios, residential entrances, and landscaped transition areas between the private and public realm.

Residential housing will be in a variety of forms and densities, including tuck-under townhomes, liner (podium) townhomes, low-rise, mid-rise, and high-rise (tower) buildings.

Most residential parking will be located in structures embedded within buildings. Additional convenience parking for retail is located on many streets adjacent to shops and services. Off-street surface parking, other than very small and occasional lots, is not proposed.

Transit opportunities will be provided by a bus rapid transit (BRT) system and non-BRT Muni transit buses that connects to the Caltrain and the 3rd Street light rail systems. The transit stops for these systems serve as the major focal points for intensified retail, commercial and residential development. Further detail regarding the approved land uses at Candlestick Point are contained in the BVHP Redevelopment Plan, the CPHPS2 Disposition & Development Agreement (as amended), and the CPHPS2 Final Environmental Impact Report (and associated Addendums).



Figure 3.2 Candlestick Illustrative Site Plan



Legend – Building Types

- Mixed-use
- Retail/Commercial
- Low-rise residential
- Mid-rise residential
- High-rise residential
- Park Buildings

Notes:

1. Refer to Section 5.3 (including Figure 5.6) for information regarding Candlestick Center.
2. Towers shown are one example of allowable tower locations (see Section 4.2.2 for details).



Candlestick looking southwest – Lower and finer grained buildings near CPSRA.





*Note: Towers shown are one example of allowable tower locations (see Section 4.2.2 for details)*

Candlestick looking northeast – CPSRA in foreground, Candlestick South in front, Candlestick Center to left.



## Neighborhoods

Candlestick will consist of four distinctive neighborhoods: Candlestick Center, Candlestick North, Candlestick South, and Alice Griffith (see the Illustrative Site Plan – Figure 3.2). A general description of the neighborhoods follows, while specific standards and guidelines are contained in Section 5.

### Candlestick Center

Candlestick Center will be the densest concentration of residential, commercial and retail activity in Candlestick Point, making it a focal point for the area. It is intended to be a mixed-use neighborhood bound by Harney Way and Ingerson Avenue and will help activate public parks along Harney Way. Uses consistent with the intent for Candlestick Center include residential above retail, multistory offices, single-use retail, hotel, and entertainment uses. Buildings and structured parking will be located to complement pedestrian-friendly activated streets and pedestrian-only Paseos.



Candlestick Center retail street.

### Candlestick North

Candlestick North will have mixed-use buildings on the north side of Ingerson Avenue. Residential buildings will be in forms ranging from low to mid to high rises. These will be structured in small blocks that will have pedestrian mews or vehicular laneways breaking the block at roughly its midpoint. Taller buildings will be located around the neighborhood's centrally located park and along the edge of the large, wedge-shaped park. Finer grained buildings will be located along the edges of the State Recreation Area providing a transition and protecting views of the Bay from inland locations.



Candlestick North at the edge of the centrally located community park.

### Candlestick South

Candlestick South will have a mixed-use edge on the south side of Harney Way. The tallest buildings may be located immediately south of Harney Way, positioning the highest densities near services, including the BRT route that runs along Harney Way. Buildings will taper down in height going towards the water and the State Recreation Area. Blocks will be fine-grained and include mid-block breaks, which can be configured as either pedestrian mews or vehicular alleyways.



Candlestick South's waterfront streets and pedestrian promenades.



### Alice Griffith

The Alice Griffith neighborhood, located north of Arelious Walker Drive, has a blend of market and affordable housing in townhomes and low-rise building forms that will total approximately 1,300 homes. The affordable housing will include replacement of the existing 256 units of public housing, low-income rental apartments and 'work-force' housing targeted to middle class families. The neighborhood is anchored by a City Park that extends through the center of the site along Egbert Avenue. This park is linked visually with the boulevard character of Egbert Avenue further south in order to create a sightline to the Bay.



Alice Griffith community park framed by townhomes and stack flats.



Precedent – Residential patios and stoops.



Precedent – Blend of transportation modes.



Precedent – Pedestrian mews.



Precedent – Animated street edges.

## 3.2 Public Streets

This section of the D4D describes general intentions for the street hierarchy and design of Public Streets. More specific standards and guidelines are contained in the approved Transportation Plan (in relation to how public streets facilitate transportation), and approved Streetscape Plan (in relation to the design of public streets, including street furniture, trees and materials).

The Candlestick street network is designed for the efficient movement of people and goods throughout and beyond the community and is also an important component of the public realm and community character. Streets are a central element in creating safe and enjoyable neighborhoods. In keeping with the City and County of San Francisco’s Transit First, Complete Streets, and Better Streets policies, the street system is designed to: prioritize walking, bicycling, and transit use; support the use of streets as public spaces for social interaction and community life; and be green spaces that enhance the City’s ecological function.

An important feature of the streets network is the inclusion of mid-block breaks, which may be developed as either pedestrian mews or vehicular laneways. The breaks further reduce the scale of the blocks allowing for greater pedestrian movement through the community. A waterfront path within the park areas will create additional pedestrian and bicycle linkages around the development.

Streets are designed for:

**Pedestrians, Bicycles, and Transit** – Small block sizes centered on a dense, compact development pattern of mixed-use transit nodes creates short walking distances, while extensive bicycle routes create a desirable alternatives to the automobile;

**Public Life and Community Identity** – Streets are designed as outdoor rooms with attractive places to sit, stop, gather, and play. They provide opportunities for neighbors and visitors to meet one another, creating a vibrant community-oriented neighborhood experience. Unique plantings, furnishings, and public art create distinct and memorable neighborhood identities;

**Safety** – Major roadways and intersections are designed to be highly identifiable and include bike lanes and high visibility signage. Residential streets incorporate traffic calming measures such as curb extensions, raised crosswalks, tight corner radii, street trees, narrow lanes, short blocks, and other appropriate measures including bulb outs at street crossings;







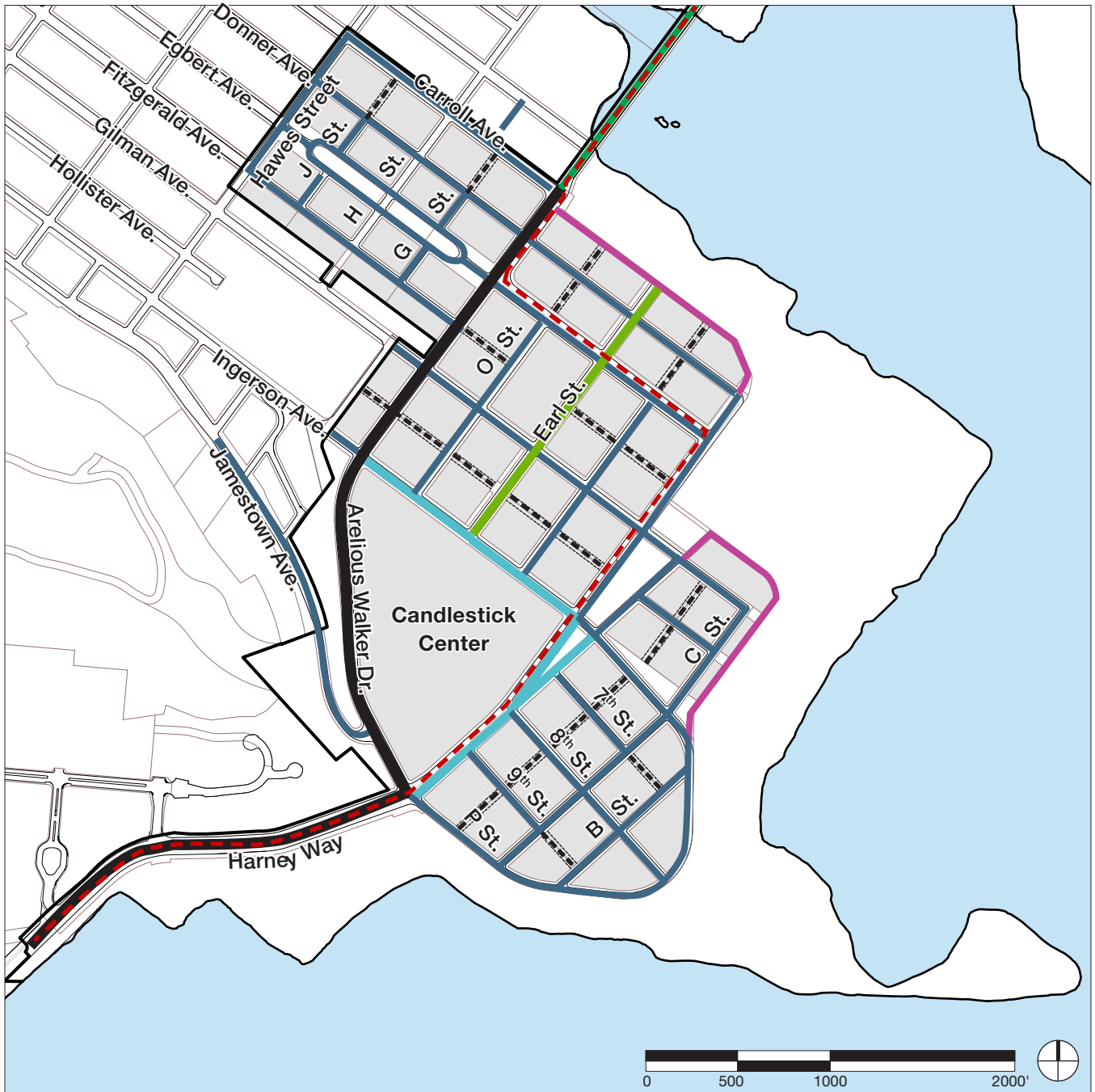

**Urban Ecology** – Streets are part of the city’s ‘green infrastructure.’ Street trees and plantings are used to help regulate climate, control storm water, cleanse air and water, and provide habitat;

**Efficiency** – A hierarchy of street types allows for the efficient movement of people and goods along designated priority corridors. Certain streets will allow for high degrees of movement and increased speeds where the majority emphasize calm and control.

Figure 3.3 Public Streets Network



**Legend**

- |  |  |
|--|--|
|  Primary Arterial                               |  Mid-block Break<br>(Public easement over private parcel) |
|  Retail Street                                  |  BRT Route  |
|  Boulevard 'Park' Street                        |  Emergency Access / Public Pathway                        |
|  Local Street                                   |  |
|  Yosemite Slough Bridge<br>(BRT and pedestrian) |  |

**Notes:**

1. Refer to Section 3.2 for standards regarding Retail Streets.
2. Refer to Section 5.3.3 for additional information regarding internal Private Streets in Candlestick Center.





Precedent – Sidewalks with street trees.



Precedent – Bicycle lanes incorporated into roadway.



Precedent – Bioswale storm water garden.

The creation of diverse street types, from quiet residential streets, to retail main streets, enhances the character of each region of the plan, facilitating wayfinding and promoting sense of place.

General public street categories include retail streets, boulevard park streets, local streets and mid-block breaks – public easements over private property which may be developed as either pedestrian mews or vehicular alleyways. The location and character of these streets is shown on the following pages. Within each of these broad street categories, there is further variety in their character and configuration. The character of streets is influenced by the building edges conditions and these are described in Section 4 of this document. The configuration of streets including specific lane and sidewalk widths, is described in the companion ‘Transportation Plan’. Standards and guidelines for the streetscape are set forth in Section 4.6.

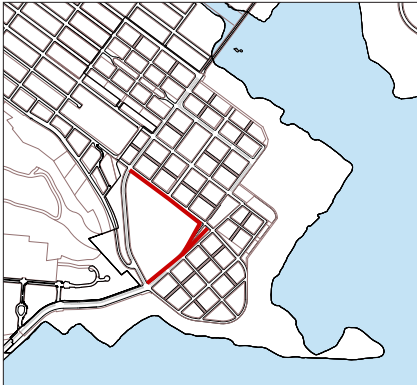

Location of Retail Streets.



Precedent – Patio areas on retail street sidewalks.



Precedent – Generous sidewalks with street trees for pedestrian priority.

**Legend**

- ① Bulb-out with Special Paving
- ② Sitting Area
- ③ Street Trees
- ④ Garden-style Planting/Bioswale Storm Water Garden
- ⑤ Street Parking
- ⑥ Street
- ⑦ Raised Crosswalk (speed table)
- ⑧ Pedestrian Lighting
- ⑨ Opportunity for Outdoor Seating

## Retail Streets

Retail streets are meant to have a ‘main street’ feel provided by generously sized and furnished sidewalks, on-street parking, transit shelters and continuous retail frontage on both sides. The plan, section and images below show the general intent including the range of street widths and building heights appropriate to the street hierarchy, character and importance. The two blocks along Harney Way and Ingerson Avenue closest to Arelious Walker Drive are exempt from the continuous retail standard.

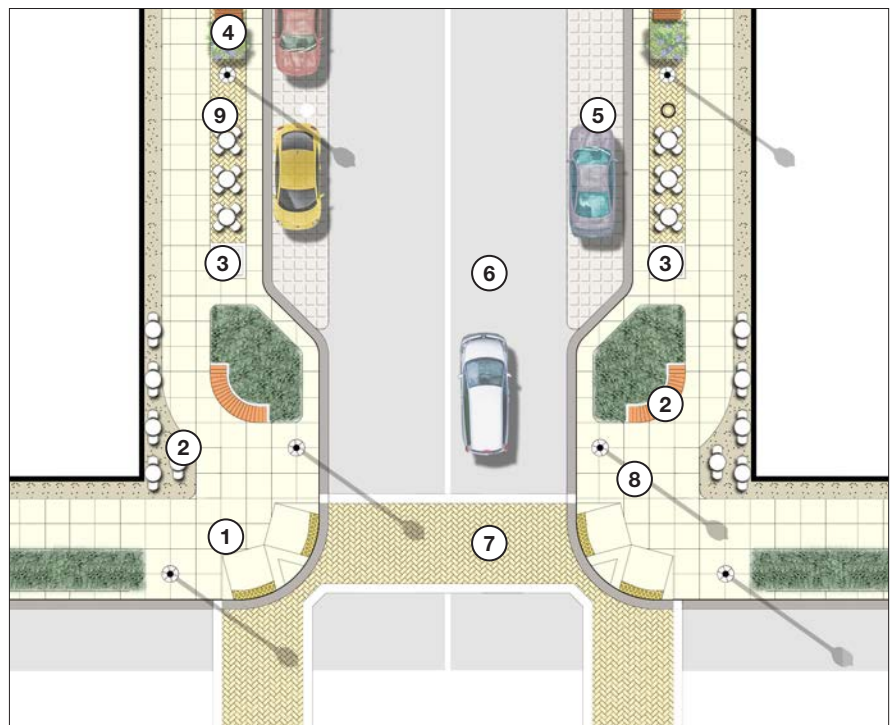
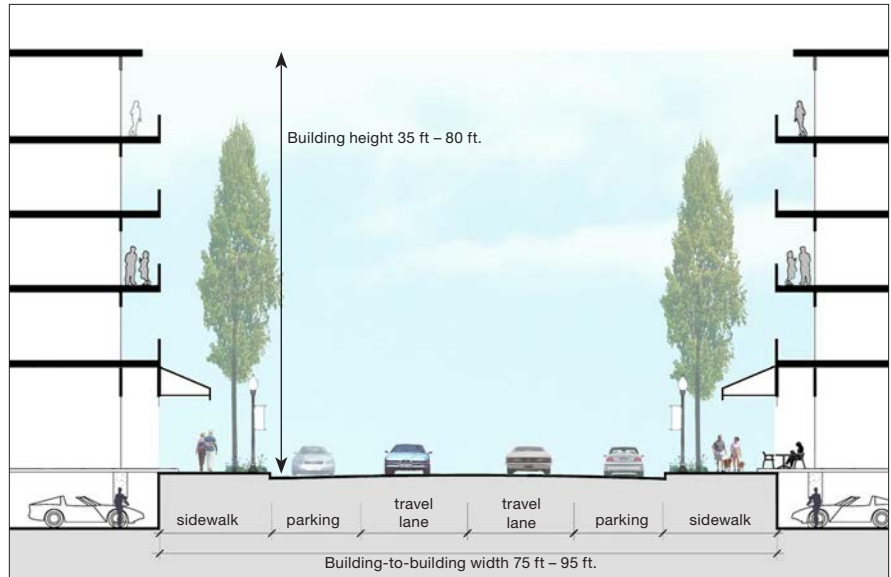

*Note: Section and plan are conceptual; specific Standards and Guidelines are described in Section 4.5.2 and Transportation Plan.*



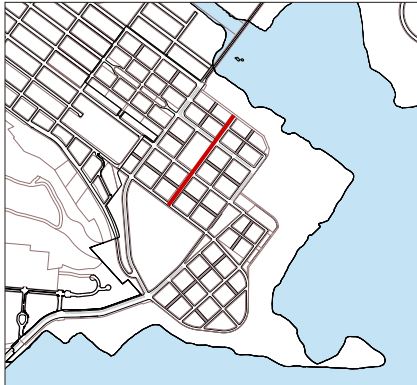

Location of Boulevard Streets.



Precedent – Dolores Street in San Francisco.

## Boulevard Park Streets

### Intent

Boulevard Park Streets are intended to provide additional open space and views out to the Bay from inland parcels. They should have generous sidewalks and tree-lined medians. The plan, section and images below show the general intent including the range of street widths and building heights appropriate to the street hierarchy, character and importance.

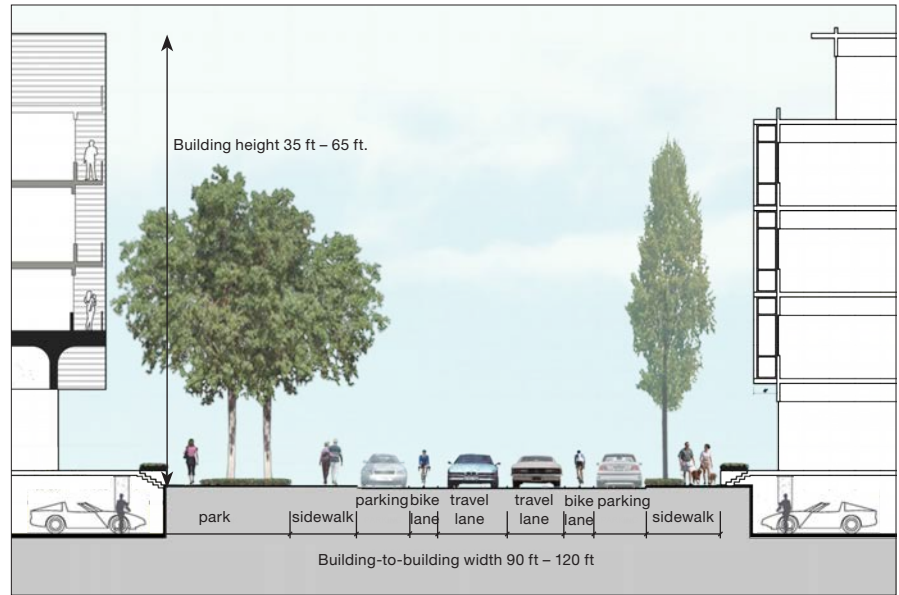

### Legend

- ① Bulb-out with special paving
- ② Bus stop with shelter and extended sidewalk zone
- ③ Sitting area
- ④ Street trees, double row
- ⑤ Garden-style planting / bioswale storm water garden
- ⑥ Streetside parking (potential for permeable paving)
- ⑦ Bicycle/travel lane
- ⑧ Bicycle parking
- ⑨ Raised crosswalk (speed table)
- ⑩ Private terraces, porches, and gardens
- ⑪ Pedestrian lighting

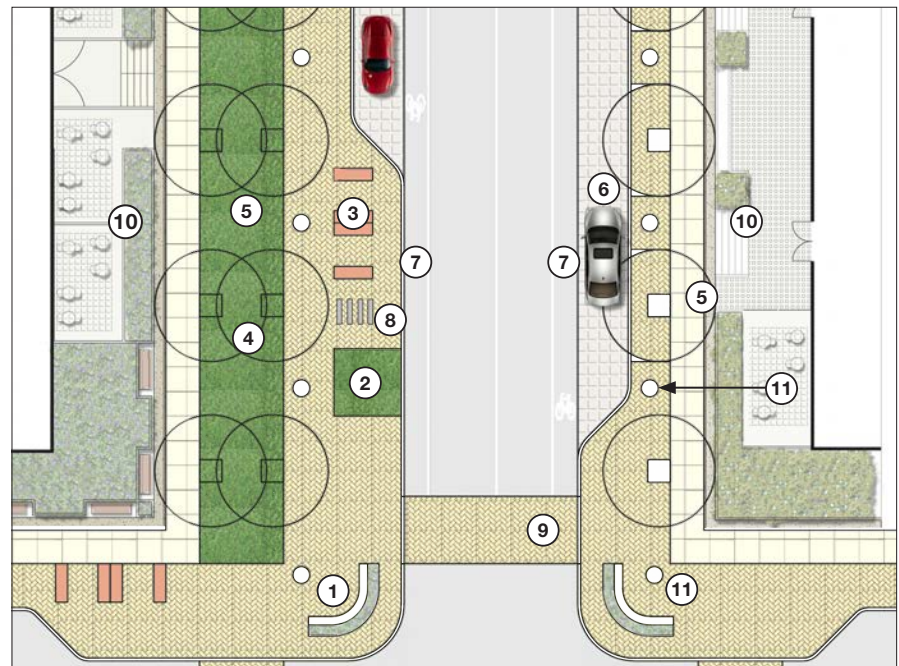

Note: Section and plan are conceptual; specific street types are described in 'Transportation Plan.'



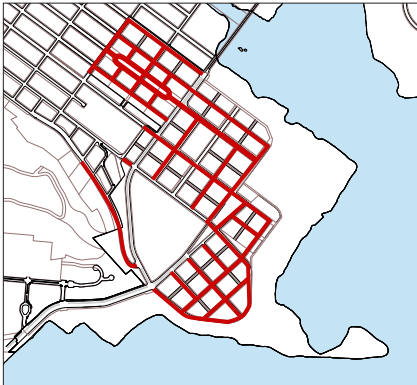

Location of Local Streets.

## Local Streets

### Intent

Local Streets should provide access for neighborhoods and function as ‘outdoor rooms’ in order to encourage socializing and recreating. They should include on-street parking, street trees and generous sidewalks. The plan, section and images below show the general intent including the range of street widths and building heights appropriate to the street hierarchy, character and importance.



Precedent – On-street parking and street trees.

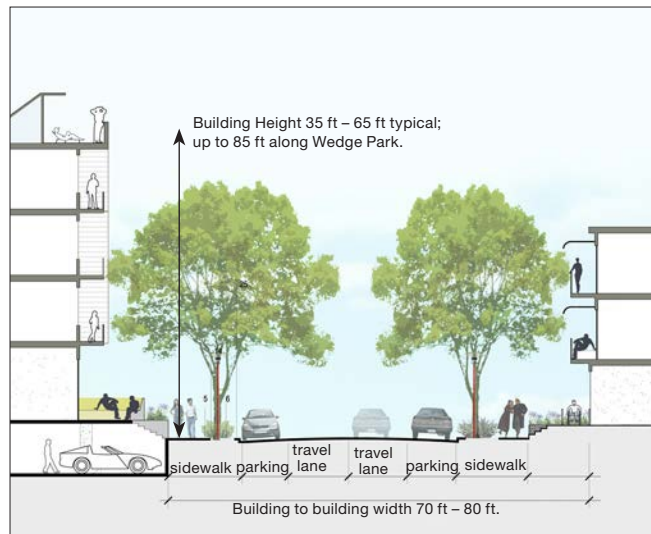

### Legend

- ① Bulb-out with special paving
- ② Sitting area
- ③ Street trees
- ④ Garden-style planting / bioswale storm water garden
- ⑤ Streetside parking (potential for permeable paving)
- ⑥ Narrow, shared lanes
- ⑦ Raised crosswalk (speed table)
- ⑧ Private terraces, porches, and gardens
- ⑨ Bicycle parking
- ⑩ Pedestrian lighting at corners

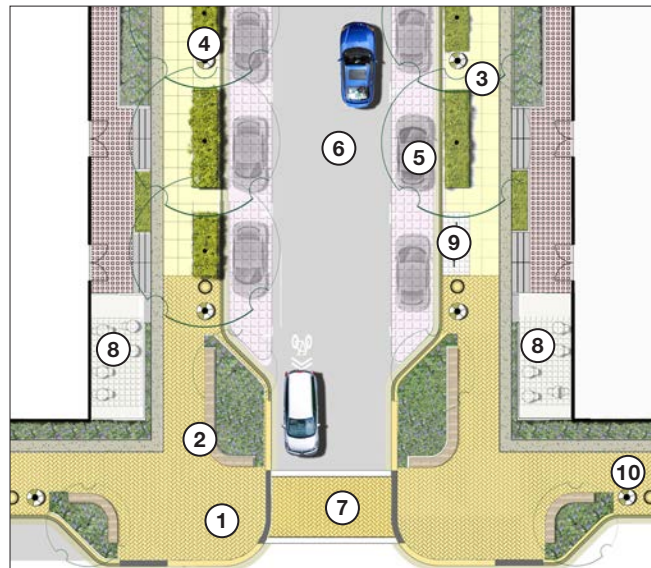

*Note: Section and plan are conceptual; specific street sections are described in ‘Transportation Plan.’*

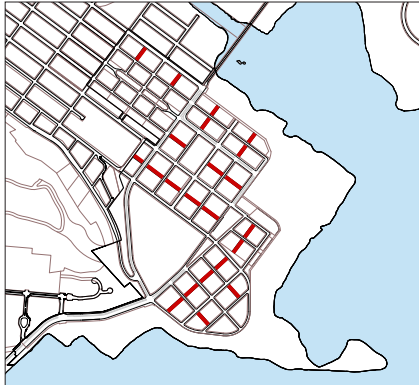

Location of Mid-block breaks.

## Mid-block Breaks

### Intent

Mid-block breaks are intended to allow public access through the middle of private development blocks in order to create a more porous circulation system and decrease the scale of building massing. Mid-block breaks are configured as either pedestrian mews or laneways, allowing vehicular movement in order to meet the requirements of adjacent buildings. The mid-block break will be a public easement on the private land of the development block. A conceptual residential pedestrian mews is depicted below. For further details, refer to Section 4.6.2.



Precedent – Mid-block break: Pedestrian Mews.



Precedent – Mid-block break: Laneway.

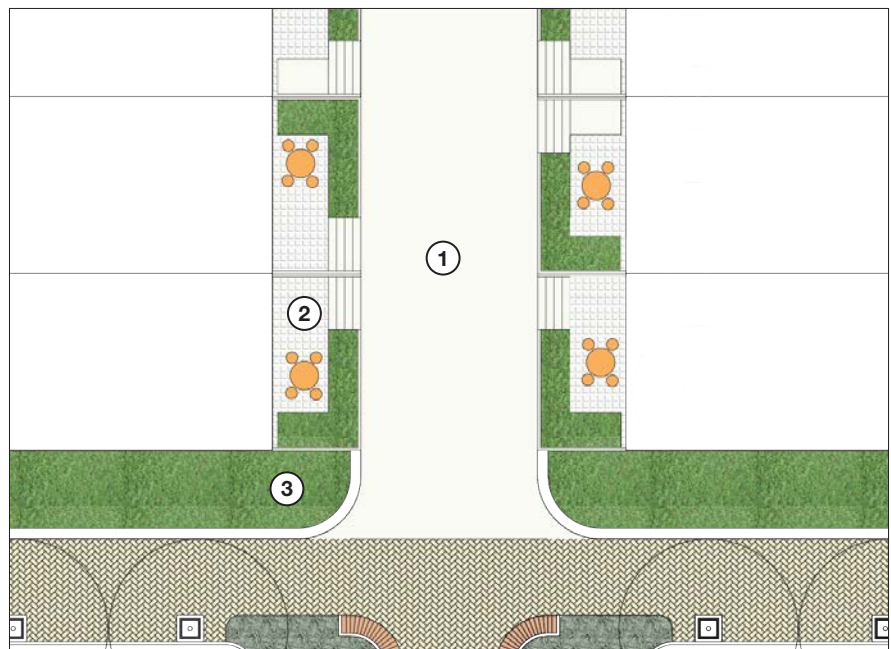
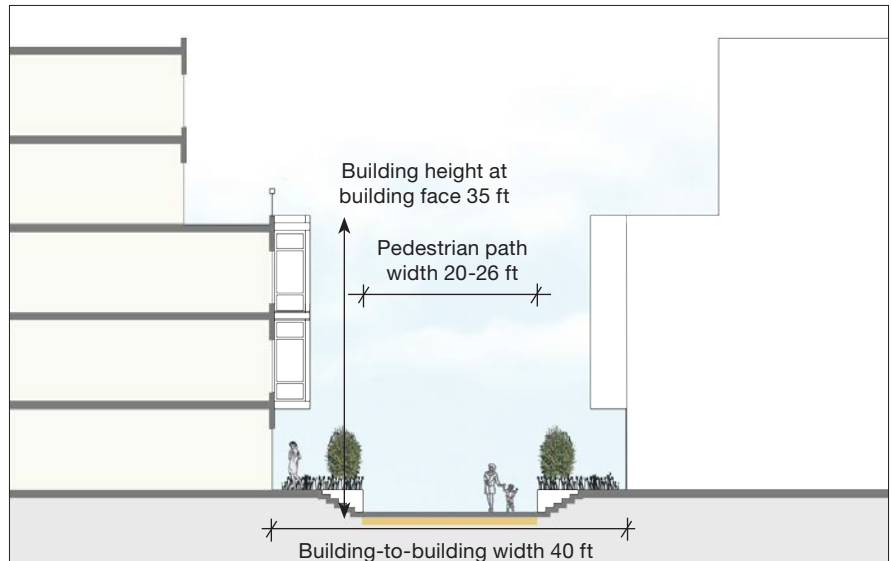

### Legend

- ① Pedestrian Path – 20-26 ft width; at grade of public sidewalk
- ② Elevated Private Patio
- ③ Landscape buffer including street trees.

Note: Section and plan are conceptual; specific Standards and Guidelines are described in Section 4.6.2 and Transportation Plan.





Precedent – Community Parks.



Precedent – Destination Parks.



Precedent – Park with family amenities.



Precedent – Playground.



Precedent – Lawn Areas for active recreation.

### 3.3 Public Parks and Open Space

*Note: The general intent for parks and open space design at Candlestick is described below. For detailed design information, standards and guidelines refer to the companion ‘Parks, Open Space and Habitat Plan’.*

The parks and open space program at Candlestick, as illustrated in Figure 3.4, will express the desires of existing neighborhood residents, the needs of future residents, overall citywide needs, and the unique opportunities presented by the site. Together these characteristics help to create a variety of park types as described below.

Incorporating this broad range of needs, input and opportunities, the parks system includes a rich diversity of programs, providing a mix of both active and quiet spaces.

Within the park system, there are two classifications of park: Community and Cultural/Heritage.

**Community Parks** – Community parks offer a mix of active and passive areas of open lawns, dog runs, play areas, tot lots, community gardens, court games, and environmental education opportunities. These parks will serve the adjacent local neighborhood and will draw regular users from within a 10 minute walking radius. The community parks adjacent to the waterfront will also attract visitors from other parts of San Francisco and beyond.

**Cultural/Heritage Parks** – The cultural and historical elements of these parks are designed to attract a broad range of visitors. In addition to regular neighborhood use, these parks draw visitors from throughout San Francisco, the Bay Area, and beyond.

The parks and open space system will generally be located and provided as described and shown on the following pages.



Figure 3.4 Parks and Open Space



**Legend**

- |   |  |
|---|--|
| ① Alice Griffith Community Park   | ⑥ State Recreation Area                  |
| ② Candlestick Community Park<br>(Final Location to be Determined in the Future) | ⑦ Yosemite Slough (outside project)      |
| ③ Bayview Gardens / Wedge Destination Park                                      | ⑧ Gilman Park (outside project)          |
| ④ Mini-wedge Community Park   | ⑨ Bayview Hill Park (outside project)    |
| ⑤ Jamestown Hillside Community Park   | ⑩ Grasslands Ecology Park (the Shipyard) |
|   | --- Bay Trail                            |

**Notes:**

1. Map is conceptual; specific park information is contained in the 'Parks, Open Space and Habitat Plan.'

2. Refer to Figure 5.6 for illustrative plan of Candlestick Center open spaces.

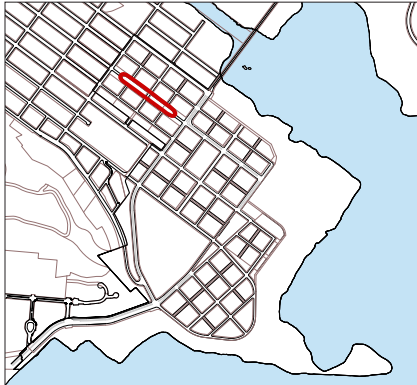

Location of Alice Griffith Community Park.



Aerial view looking north west.

### 3.3.1 City Park Descriptions

The development shall provide for five City Parks described generally as follows. Specific design shall be developed in consultation with the neighborhood.

#### 1. Alice Griffith Community Park

The Alice Griffith Community Park will serve as the commons for the Alice Griffith neighborhood. The park will be located on Egbert Avenue, which will be a one-way couplet around the park. A continuous four story or greater street wall will surround the park edge in order to frame and animate the space.

The park will offer a mix of active and passive areas that could include an open lawn, play areas, a tot lot, a dog run, community gardens, a shade pavilion with barbecue and picnic tables, a basketball court, and a bioswale stormwater garden.

Figure 3.5 Conceptual Plan – Alice Griffith Community Park





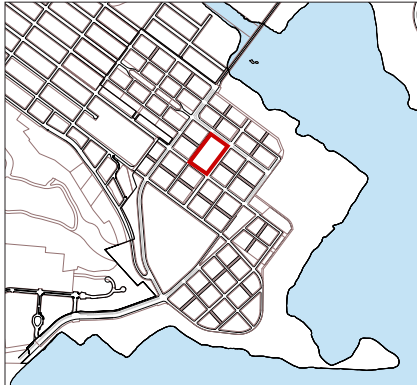

Location of Candlestick Community Park – Final location to be determined in the future.



Aerial view looking north east.

## 2. Candlestick Community Park

Candlestick Community Park will be strategically located near the center of the built up area at Candlestick so that it serves as the ‘living room’ and meeting place for residents in the Candlestick North neighborhood. The final location of the park within the neighborhood will be determined in the future; however, if relocated, it will be in the central region of the Candlestick North Neighborhood, centrally located and well-served by the transportation network. Regardless of its location, the park will maintain the approximately 3 acre size shown below.

Compared to the waterfront and water view parks, Candlestick Community Park is meant to be a more urban experience. The park offers a mix of active and passive areas including, for example, an open lawn, a playground / tot lot, gardens, seating areas and volleyball and basketball courts.

Figure 3.6 Conceptual Plan – Candlestick Community Park





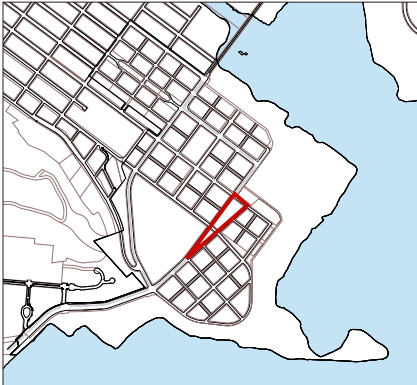

Location of Bayview Gardens/Wedge Destination Park.

### 3. Bayview Gardens / Wedge Destination Park

The Bayview Gardens/Wedge Park will be the ‘Central Park’ for the urban development of Candlestick, providing views of the South Basin and the Shipyard, and linking the center of Candlestick with the State Recreation Area. This park includes virtually all of the passive programs found elsewhere in the open space system; however, here they are condensed in a smaller area and delivered to the heart of the community. Specific emphasis here is placed on signature forms and landscape expressions. Within these forms are ecological gardens, a plaza, reflecting ponds, shade pavilions, children’s playground, passive lawn areas and a bioswale storm-water garden. The southerly portion is an urban plaza, including a BRT stop and on street parking.



Aerial view looking south west.

Figure 3.7 Conceptual Plan – Bayview Gardens / Wedge Destination Park

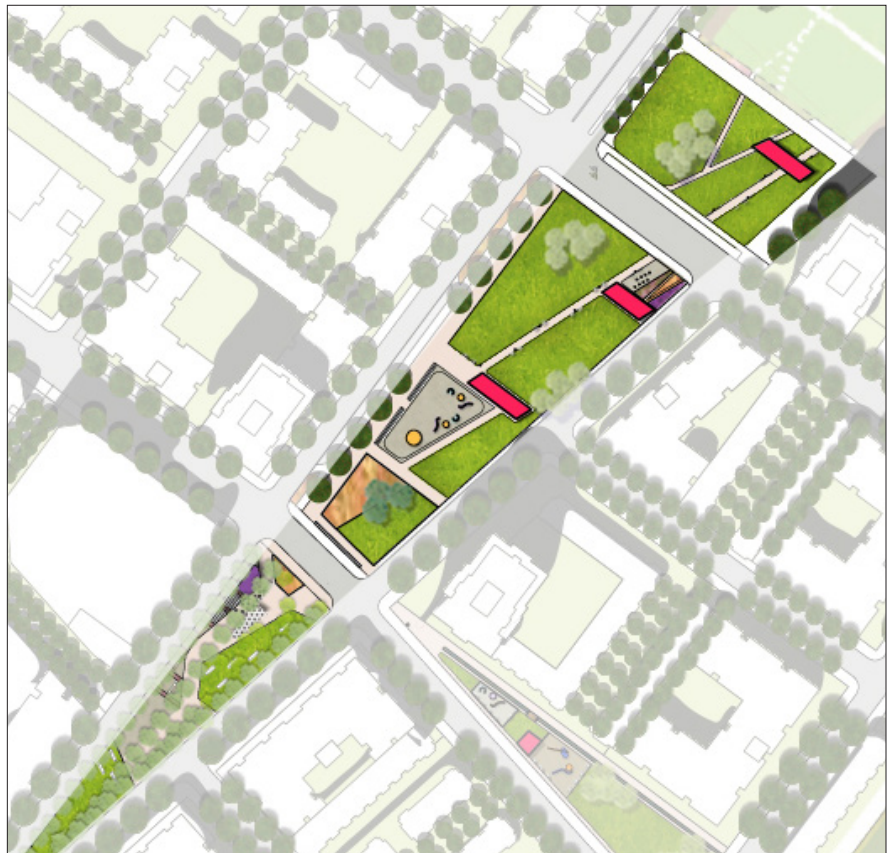



Location of Mini-wedge Community Park.



Aerial view looking south east.

#### 4. Mini-wedge Community Park

The Mini-wedge Community Park provides dramatic views of the Bay and it serves as a primary connector between the urban core of Candlestick and the State Recreation Area beach area. Programmatic elements include a playground/tot lot, dog run, shade pavilion and open lawns with views to the bay. This park also serves an ecological function, intercepting and cleansing urban storm-water runoff before it enters the bay.

Figure 3.8 Conceptual Plan – Mini-wedge Community Park



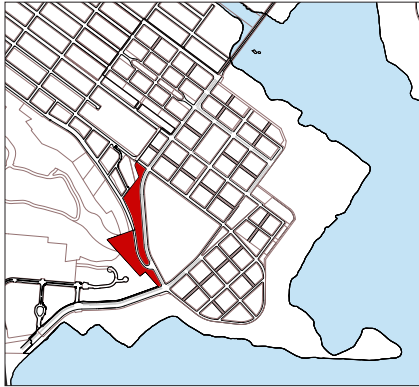

Location of Jamestown Hillside Community Park.

### 5. Jamestown Hillside Community Park

This park is located at the base of the Bayview Hill Park. The existing site is a steep, rocky slope that was graded and terraced for the construction of the former Candlestick Stadium. Following the recommendations of the Bayview Hill Natural Areas Plan, this park area will be enhanced with new native plantings to increase that habitat value of the site and to help to create a habitat link between Bayview Hill and the Bay. The park will have access to Candlestick Center via a new Ingerson Avenue extension as well as at Jamestown Avenue and Arelious Walker Drive.

Figure 3.9 Conceptual Plan – Jamestown Hillside Community Park

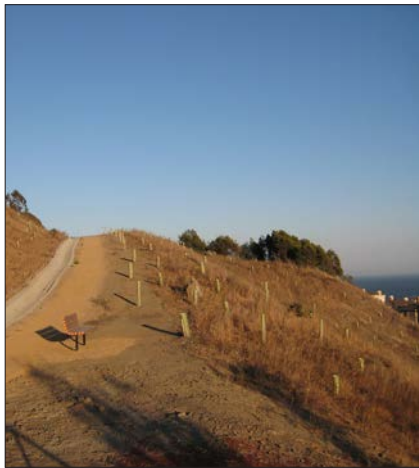

Existing Bayview Hill landscape.





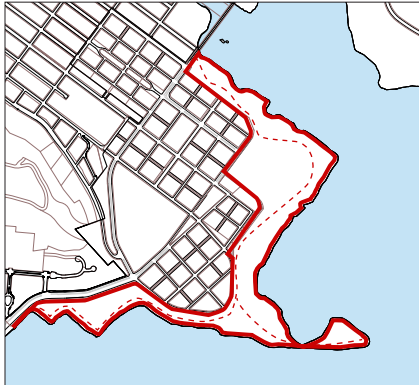

Location of State Recreation Area and Bay Trail.



Precedent – Main Park.

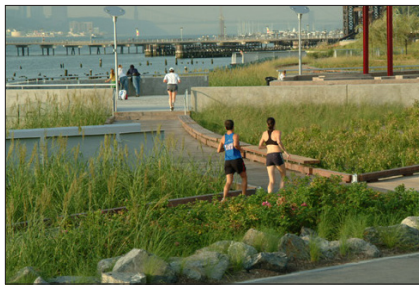

Precedent – Bay Trail.

### 3.3.2 State Recreation Area Description

The Candlestick Point State Recreation Area (CPSRA) is a unique opportunity in the State Recreation Area system and along the San Francisco Bay shoreline to create a model urban recreation area that links city residents and regional visitors to the diversity of estuary and upland habitats of the Bay and demonstrates integrated sustainable design principles for reclaiming fill areas for park uses.

Within the State Recreation Area, there are two main zones of activity.

**Main Park** – Although this park stands alone as a separate waterfront open space system, it is the primary connector that links the other various parks together and provides the regional link that makes this a greater system of open space. The zones of this park are the connective tissue of the open space system employing a simple, sensitive, and expressive palette of landscape materials to allow the park to grow over time. Native grasslands, woodland groves, and an ecological focus in these areas provide a system for choreographing the landscape experience. Examples of these CPSRA zones are the Last Rubble, the Point and the Last Port.

**Bay Trail** – Within the State Recreation Area, the Bay Trail links together all elements of the park and provides a system of clear connections to the regional green ways and waterways. This is the primary recreational route in the new open space system and will encourage users from adjacent neighborhoods, and other areas of the city to utilize the new open spaces of the development.

#### Area Planning Process

There will be a separate planning process for the CPSRA that will be undertaken by California State Parks. This process will include a General Plan addressing programming and policy, and a Master Plan addressing specific design. The State, City, community, and developer will work together to initiate the master planning process leading to the refurbishment of CPSRA.

The following principles are proposed for consideration in this design process. These are illustrated in the conceptual plan on the next page and in Figure 3.10.

- Design city parks and state recreation areas to feel from a user perspective as one park system despite potential programmatic and operational differences between jurisdictions.
- Develop a park that is programmed and designed for safe and active 18 – 24 hour daily use by the public.
- Design a pedestrian and bike accessible transition zone between all private development parcels and the park.
- Develop frequent routes into the park from the neighborhood aligning with the planned street network with major linkages with transit stops, bike routes and linear green way features.
- Create a mixture of passive and active spaces that activate the open space drawing neighbors and visitors to the waterfront.

- Provide duplicative trail systems including linkage to a Class One Bike Trail and multi-use recreation trail close to neighborhoods, a continuous Bay Trail close to the water, and multiple linkages between.
- Install multiple human powered boat access points including facilities for windsurfers south of Bayview Hill and kayak/canoe facilities in Yosemite Slough.
- Preserve and expand the existing pocket beach.
- Integrate stormwater treatment systems with the neighboring development to provide model/demonstration sustainability systems and habitat spaces.
- Utilize sustainable design principles through park planning to expand the ecological functions of the recreation area and minimize resource consumption by park facilities, programs and users.
- Introduce limited commercial uses to provide food and recreational services for visitors.
- Balance dedicated parking facilities for the recreation area with available on and off street parking provided in the neighboring development and transit access to the area.
- Upgrade existing and install additional fishing and viewing piers into the bay.
- Provide multiple picnicking and barbecuing facilities to accommodate family and social gatherings in multiple areas of the park, and consider larger scaled gathering opportunities for events.
- Provide rest rooms and other support infrastructure.



Draft Concept Master Plan prepared by AECOM for California State Parks.

Figure 3.10 Conceptual Plan – Candlestick Point State Recreation Area







# 4

---





# Land Use, Design Standards and Guidelines

- 4.1 Land Use
- 4.2 Height, Bulk and Massing
- 4.3 Building Design
- 4.4 Signage
- 4.5 Parking and Loading
- 4.6 Streets



## 4 Land Use, Design Standards and Guidelines

This section, Land Use, Design Standards and Guidelines, covers elements applicable to all areas within Candlestick (except as otherwise noted in Section 5.3 for Candlestick Center). (For additional elements specific to individual neighborhoods see Section 5 Neighborhood Standards and Guidelines).

*Standards* are mandatory actions, generally described in absolute terms such as by measurement or location. *Guidelines* are encouraged actions, which if adhered to in spirit will result in projects that best fit the vision for the site.

The section has six parts:

- 4.1 Land Use
- 4.2 Height, Bulk and Massing
- 4.3 Building Design
- 4.4 Signage
- 4.5 Parking and Loading
- 4.6 Streets

### 4.1 Land Use

#### 4.1.1 Development Blocks

##### Intent

Development blocks should be similar in scale to the surrounding Bayview neighborhood whose blocks typically approximately 600 ft by 275 ft. Mid-block breaks, in the form of pedestrian mews or vehicular laneways, have been added to several blocks. Open space has been located so that all development blocks have convenient access.

##### Standards

**Block Location** – Development blocks and mid-block breaks shall be located as close as possible to the location shown on Figure 4.1 on the following page.

**Street Location** – Streets shall be located as close as possible to the location shown on Figure 4.1. Final locations and dimensions shall be per the companion ‘Transportation Plan’.

**Park Location** – Parks shall be located as close as possible to the location shown on Figure 4.1. Final locations and dimensions shall be per the companion ‘Parks, Open Space and Habitat Concept Plan’.

**Turning Radii** – Certain corners within the development are rounded in order to accommodate buses and emergency vehicles. Those corners shall be rounded to accommodate a 41 ft curb turning radius (modeled as AASHTO WB-40).

Figure 4.1 Development Blocks



Legend

-  Block
-  Neighborhood Boundary
-  Street/Public Right of Way
-  Open Space
-  Mid-block Break/Public Easement
-  Block Number

---

## 4.1.2 Land Use Districts

The BVHP Plan establishes Land Use Districts for the Candlestick site, which is in Zone 1 of Project Area B of the BVHP Plan. As shown on Figure 4.2, three Land Use Districts are established for Zone 1 as follows:

- Candlestick Mixed-Use Residential District
- Candlestick Center Mixed-Use Commercial District
- Open Space District

The permitted land uses within each of these Land Use Districts are set forth in the BVHP Plan. Development of structures and uses of land within Candlestick are required to conform to the BVHP Plan and this D4D. To provide context for the remainder of this document, the general types of uses permitted by the BVHP Plan in these Districts are summarized below. This D4D provides the detailed design guidelines and development standards for all development within the Candlestick site.

The **Candlestick Mixed-use Residential District** provides the major housing development area, which will be comprised of lower scale residential development in the northern part of the site and higher density mid-rise to high-rise residential in the central part of the site. A mixture of building types and unit sizes will be provided in a range of densities to accommodate a variety of households. Neighborhood retail is an allowed use in this District, and indeed is encouraged where it is located on the ground floor in central areas within the neighborhood. Personal service, civic and institutional uses, and parks are also permitted.

The **Candlestick Center Mixed-use Commercial District** is located in the southwest quadrant of the site. It serves to facilitate the development of mid-rise commercial and/or residential uses with ground floor retail along primary streets. The mixed-use neighborhood is designed to encourage retail, commercial, hotel and cultural arts activities. This will be achieved through compact, horizontal mixed-use whereby different activities and land uses locate in close proximity to each other; or through vertical mixed-use which will allow for more than one land use category within a single building – such as a residential apartment complex with retail uses on the ground floor. Educational, community activity, and park and recreation uses are also permitted.



The **Open Space District** will provide for quality open spaces and public parks, including active recreation facilities such as playing fields, gardens and walking/bicycling trails. A hierarchy of open spaces will be provided across Candlestick to include small urban parks and plazas, tree-lined parkways along streets and major park spaces along the waterfront. Public serving buildings to a maximum of 40 ft shall be allowed, including gymnasiums, amphitheater, rest rooms, food-service facilities, restaurants, and buildings for the provision of recreation related services (for example sports equipment rental).

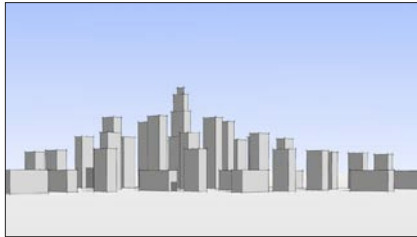

Figure 4.2 Land Use Districts



Legend

-  Candlestick Mixed-Use Residential District
-  Candlestick Center Mixed-Use Commercial District
-  Open Space District



Cluster high-rise buildings near center of neighborhood.

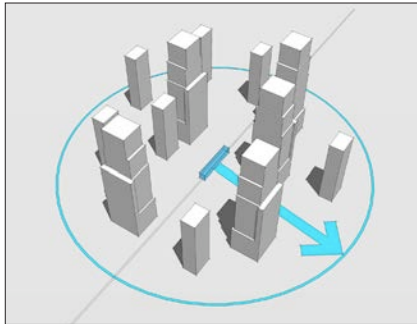

Cluster high-rise buildings near transit.

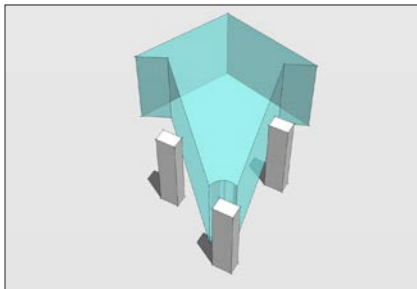

Respect view corridors.

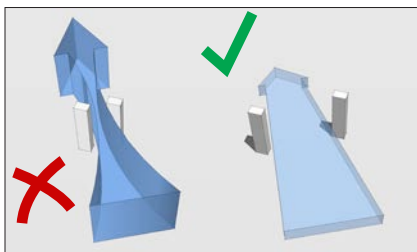

Avoid wind tunneling by staggering tower locations.

## 4.2 Height, Bulk and Massing

This section describes the intent, standards and guidelines related to height, bulk and massing of blocks and buildings within Candlestick Point. Further bulk and massing controls for commercial, residential, retail and parking buildings within Candlestick Center are established in Section 5.3, and shall prevail in the event of conflict with controls established in this Section 4.2. This section contains six subsections:

- 4.2.1 Building Types
- 4.2.2 Height
- 4.2.3 Bulk & Massing
- 4.2.4 Street Wall
- 4.2.5 Sunlight/Shade
- 4.2.6 Wind

Height is regulated to provide a variety of walls that frame public space, and in some cases protect views. Within development blocks, the bulk of the building is regulated by building coverage at various height thresholds to ensure that the overall bulk of buildings is an appropriate scale and allows for light and view penetration to the street level. The massing of individual buildings is regulated by way of maximum lengths, diagonals, apparent face and upper floor stepback. At the finest grain, the building edge is regulated to ensure an appropriately scaled and detailed edge at the public interface. Finally, considerations of sunlight/shade and wind are regulated to ensure a comfortable environment in the public realm and in the buildings.

Height controls for all building types, inside and outside of Candlestick Center, are found in the following Section 4.2.2.

## 4.2.1 Building Types

Building types are defined as described in Table 4.1 below.

Table 4.1 Building Types

LOW-RISE	MID-RISE	SIGNATURE BUILDING	HIGH-RISE
			
<p>Any building with a maximum height of 65 ft or less.</p>	<p>Any building with a maximum height greater than 65 ft, but less than 120 ft.</p>	<p>A signature building with a maximum building height of 120 ft.</p>	<p>Any building with a maximum height greater than 120 ft.</p>

## 4.2.2 Height

### Intent

Heights are regulated in order to achieve several objectives:

- Integrate the new development with the scale of the surrounding Bayview neighborhood.
- Cluster density near services like transit, shopping and jobs.
- Reinforce focal points located at the center of the development.
- Protect views and sun in specific locations and mitigate wind tunneling effects.

### Standards

**Parks and Open Space** – The maximum allowable building height in a park or other open space is 40 ft.

**Low-rise and Mid-rise** – The location and height of low-rise and mid-rise buildings is shown in Figure 4.3. Where a block has multiple height zones, the building(s) shall conform to the maximum percentage(s) of the block's developable area depicted in Figure 4.3. For the purposes of this provision, the developable area is the area of the block excluding land required for a mid-block break and the applicable ground floor setback areas.

**Signature Building** – A signature building within Candlestick Center at the corner of Harney Way and Ingerson Avenue shall be a maximum of 120 ft.

**High-rise (Tower)** – The location of high-rise buildings (towers) is shown in Figure 4.3. The standards (S) and guidelines (G) that regulate the location and height of high-rise buildings are set forth in Table 4.2.



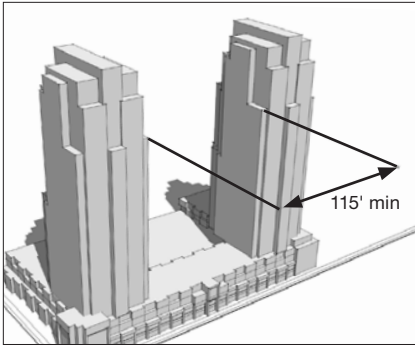

High-Rise separation.

- Tower Location – Towers are either fixed (noted as fixed location) or allowed within an allowable zone, within which an encouraged location is shown.
- Tower Benching – In order to encourage variation in tower height and preserve the project skyline profile, any tower not built to the maximum allowable height shall maintain the same maximum height differential to the next closest tower (not including towers at maximum height), while not exceeding the maximum allowable height. For example, if Tower 1 has a maximum height of 240 ft, and Tower 2 has a maximum height of 280 ft, these two towers shall maintain a minimum 40 ft height difference.
- Tower Separation – Towers shall be separated by a minimum 115' to minimize view obstruction, increase privacy, limit wind tunneling impacts, and limit lighting impacts.
- Buildings taller than 100 feet are subject to mitigation to reduce impacts to birds as outlined in MM-BI-20a.1 and MM-BI-20a.2 of the Final Environmental Impact Report for Candlestick and the Shipyard project.

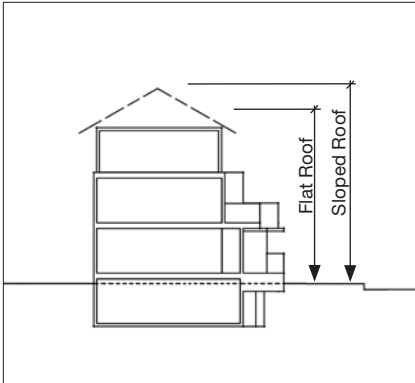

Height measurement for Flat Roof & Pitched Roof on flat sites.

### Height Measurement – Heights are measured as follows:

- Heights shall be measured from curb level of the fronting street to the top of a flat roof or mid-point of a sloped roof.
- For sloping sites, the height measurement shall be taken from the highest mid-point along the streets that the building fronts, from there drawing a flat plane across the site to establish building height.

### Height Measurement Exceptions – The following appurtenant structures are exempt from building height measurements provided their height, measured from the top of the roof, does not exceed 10 ft or other height as noted:

- Ornamental architectural features, such as turrets, parapets, corner towers, or other accentuating features provided they conform to Proposition K regulations where required.
- For Residential/Mixed-Use/Commercial buildings, at or below 180 feet, height of mechanical and roof mounted elevator core equipment shall extend to a maximum of 18 ft. provided their combined coverage does not exceed 30% of building roof area.
- Tower buildings above a height of 180 feet shall be exempt from roof area coverage restrictions for rooftop mechanical screening.
- In tower buildings exceeding 180 feet, the height of the mechanical and rooftop equipment and screening for said equipment may extend above roof line up to a maximum of 10% of the total building height.
- Architectural and landscape screening designed to conceal mechanical and roof mounted equipment.
- Sustainability elements, such as photovoltaic cells, small-scale wind turbines suitable for residential development, storm water catchment/treatment equipment, solar water heating equipment.
- Enclosed amenity spaces to a height of 12 ft where roof is designed as an accessible outdoor common area if coverage of enclosed amenity space is no more than 20% of building roof area.

### Guidelines

**Low-rise and Mid-rise** – For blocks with multiple height zones, the precise location of the height change for the building(s) on the block is flexible, provided the heights remain generally consistent with the locations depicted in Figure 4.3.

## Building Heights

Table 4.2 Maximum High-rise Podium Heights and Building Heights

HIGH-RISE MAXIMUM BUILDING HEIGHTS			
HIGH-RISE <sup>1</sup>	MAXIMUM OVERALL BUILDING HEIGHT (Ft)	MAXIMUM PODIUM HEIGHT (Ft)	REMARKS
A	S – 220	S – 65	S – Shall be located on Egbert Avenue to frame the park and reinforce the park street. G – May be located anywhere within allowable zone, however is encouraged to be located on center line axis of Candlestick North neighborhood park in order to reinforce the park’s rectangular shape and frame its northern edge.
B	S – 240	S – 65	S – Shall be located at the corner of Harney Way and Egbert Avenue in order to anchor the northeastern corner of Bayview Park and offer views of the park while not crowding the CPSRA.
C	S – 220	S – 65	S – Shall be located on Earl Street in order to frame the park and reinforce the park street. G – May be located anywhere within allowable zone, however is encouraged to be located at the corner of Earl and Fitzgerald in order to optimize separation of towers A, C and E.
D	S – 320	S – 65 Fronting Gilman S – 85 Fronting Harney	G – May be located anywhere within allowable zone, however is encouraged to be located on Gilman Avenue to optimize tower separation of towers C, D and E.
E <sup>2</sup>	S – 170	S – 65	S – Shall be located on Earl Street in order to reinforce the street. G – May be located anywhere within allowable zone, however is encouraged to be located at the Gilman Avenue corner in order to frame the park.
F <sup>2</sup>	S – 320	S – 85	S – Shall be located at the corner of Ingerson and Harney Way in order to anchor the southern end of Bayview Park, reinforce the Avenue corner’s central position in the neighborhood and offer views of the park. G – Encouraged to be at or near full allowable height in order to reinforce this central location.
G	S – 240	S – 65	S – Shall be located at the corner of Gilman Avenue and Harney Way’s southern extension in order to anchor the southeastern end of Bayview Park and offer views of the park.
H	S – 320	S – 65	S – Shall be located at the corner of Ingerson and Harney Way’s southern extension in order to anchor the intersection of the two wedge-shaped parks and offer views of the parks. G – Encouraged to be at or near full allowable height in order to reinforce this central location.
I	S – 420	S – 65	S – Shall be located in the position indicated, roughly half way along 7 <sup>th</sup> Street between Harney Way and C Street in order to preserve a view shed from Bayview Hill Park to Candlestick Point. G – Encouraged to be at or near full allowable height in order to reinforce this central location.
J	S – 370	S – 65	S – Shall be located on 9 <sup>th</sup> Street on east side of the mid-block break to optimize the separation from tower I. G – May be located anywhere within the allowable zone, which provides for preservation of a viewshed from Bayview Hill Park to Candlestick Point. G – Encouraged to be at or near full allowable height in order to reinforce this central location.
K	S – 320	S – 65	G – May be located anywhere within allowable zone which provides for preservation of a viewshed from Bayview Hill Park to Candlestick Point, however is encouraged to be located on Ingerson at the southern corner of the Mini-Wedge Park in order to anchor the park. G – Encouraged to be at or near full allowable height in order to reinforce this central location.

S – Standard  
G – Guideline

<sup>1</sup> See Figure 4.3 for location of high-rise buildings.

<sup>2</sup> Pending the adoption of findings per planning code Section 295.



Figure 4.3 Building Heights

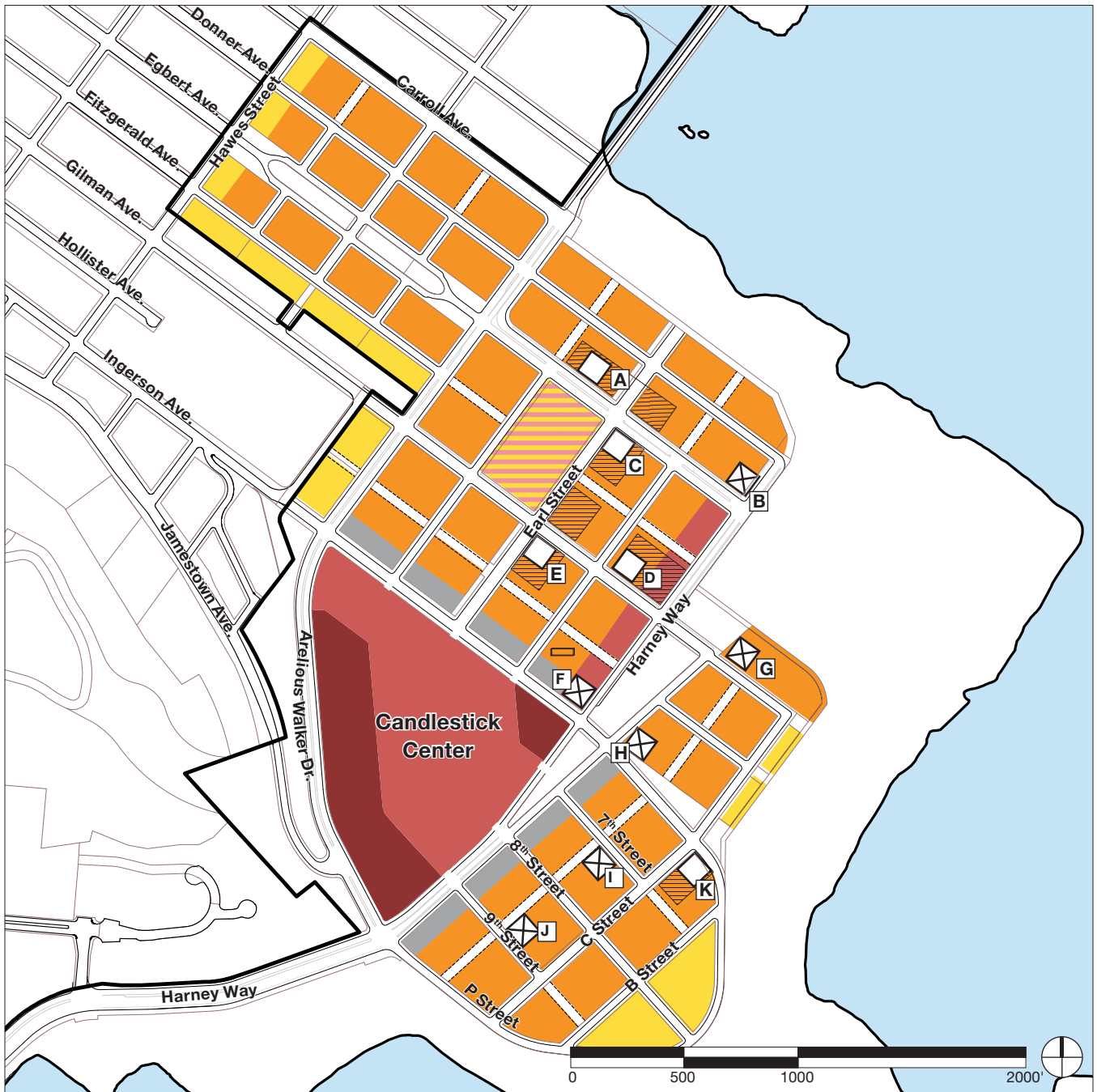

Legend

Low and Mid-Rise Maximum Height

- 40 ft
- 65 ft
- 80 ft
- 85 ft
- 120 ft
- 40 ft: if park  
85 ft: if development parcel

— Project Boundary

High-Rise Tower Location\*

- Fixed high-rise location
- Encouraged high-rise location
- Allowable high-rise location zone

\* See Table 4.2 for maximum heights.

Notes: For blocks with multiple height zones, the precise location of the height change for the building(s) on the block is flexible, provided the heights remain generally consistent with the locations depicted in this Figure. See Table 4.3 for applicable Development Block Coverage that must be considered alongside these height percentage zones.

### 4.2.3 Bulk & Massing

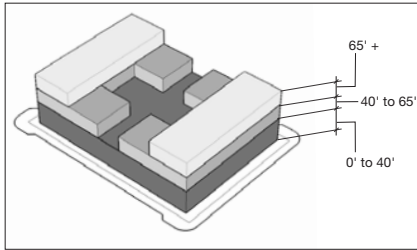

Development block coverage.

#### Intent

The following standards governing bulk and massing intend to facilitate building shapes that fit comfortably within their surroundings, are friendly and unimposing to pedestrians, achieve an attractive urban form, and are interesting. The mass of buildings should be shaped in such a way as to create fine-grained forms, reinforce the street and block pattern, and protect surrounding views and sunlight. In Candlestick Center, office buildings, retail buildings and parking facilities are not subject to the following bulk and massing controls. See Section 5.3.5 for bulk and massing controls for these building types in Candlestick Center.

#### Standards

**Development Block Coverage** – Within development blocks, the bulk of the building is regulated by block coverage at various height thresholds to ensure that the overall bulk of buildings is an appropriate scale and allows for light and view penetration to the street level. Building height(s) and development block coverage, along with all other applicable design standards, both comprise development controls that must be calculated separately to determine allowable building massing. Block coverage by all habitable and non-habitable buildings, including projections and structured parking, is limited as indicated in Table 4.3. A development block is defined as all land inside the legal property line. Inside Candlestick Center, the development block is defined as all land bounded by public street, Private Street, plaza, Paseo or neighboring development. For the purpose of calculating coverage, the area of the block shall be exclusive of required setbacks and mid-block breaks and Paseos. Notwithstanding the parcel coverage standards, individual buildings within the parcel shall not exceed the sizes set forth in Table 4.4.

Table 4.3 Development Block Coverage

DEVELOPMENT BLOCK COVERAGE	
HEIGHT (FT)	COVERAGE
0 – 40	100%
40 – 65	75%
65 +	50%

**Bulk Controls** – Maximum floor plate sizes, plan lengths, and diagonals to limit the bulk of buildings are listed in Table 4.4. The maximum diagonal dimension shall be measured between the two points of a building’s longest diagonal separation.

**Massing Controls** – Controls of apparent faces and stepback of upper floor(s) to limit the massing of buildings are also listed in Table 4.4.

**Apparent Face** – The unbroken plane of a building or ‘apparent face’ shall not exceed a maximum length without being broken by a change – either an offset in the horizontal plane, or a change in fenestration and/or material, or both in the case of high-rise buildings. There are different standards for the base section and upper section of the building to reflect the desire for a finer grain of building articulation at the street level. For Low- and Mid-Rise

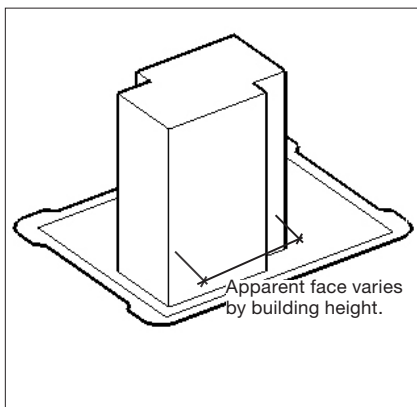

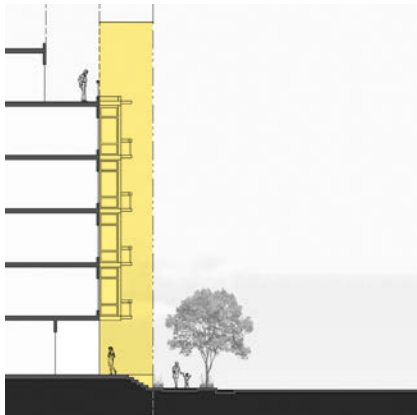

Setbacks.



Build-to Lines.



Stepbacks.

buildings, the base is defined as the first 20 ft of the building elevation. For High-Rise buildings, the base is defined as the first 35 ft of the building elevation. See Table 4.4.

**Upper Floor(s) Stepback** – The upper floor(s) of low and mid-rise buildings above a specified height shall step back a minimum of 20% of the floor plate size relative to the floor immediately below, as defined in Table 4.4 and Table 4.6. See Section 5.3 for stepback standards for office and commercial retail buildings within Candlestick Center. For stepback standards for residential buildings in Candlestick Center, see Table 4.6.

**Podiums** – High-rise buildings may have a podium, defined as a base whose plan dimensions are greater than those of the floors above. The podium height for high-rise buildings shall not exceed the podium height limit provided in Table 4.2. All podium floors with a maximum height (distance to ground) below 85 feet shall not be subject to the bulk controls (maximum floor plate, maximum plan length and maximum diagonal) for high-rise buildings shown in Table 4.4. All podium floors with a maximum height of 85'-105' shall be subject to the bulk controls for mid-rise buildings of 85-105 feet shown in Table 4.4. Notwithstanding these exceptions, the podium shall be subject to massing controls and all other applicable regulations. Further standards and guidelines for high-rise podiums are provided in Section 4.3, Building Design. Additional standards regulating specific building types such as high-rise buildings are contained in Section 4.3.

#### 4.2.4 Street Wall

The section has a definition of the key controls, sets forth the standards, and concludes with a series of cross sections that illustrate the standards by building use. For building elevations within the interior of Candlestick Center, Build-to Line standards are found in Section 5.3.6.

##### Intent

In order to control the quality and character of the block edges and street walls, and for controlling the expression of the mass of the buildings, standards for building uses are set forth for:

- A Setbacks
- B Build-to Lines
- C Stepbacks
- D Projections



As a means of controlling the quality of the at-grade environments these streetwall controls also include considerations for grade separation, retail space heights and depths, and underground parking.



Projections.

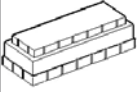
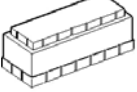
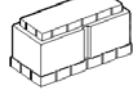
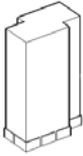
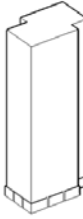

Table 4.4 Massing

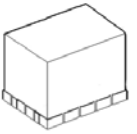
BUILDING LENGTHS AND SIZES									
BUILDING TYPE	LOW-RISE	MID-RISE		HIGH-RISE				SIGNATURE-BUILDING	
BUILDING HEIGHT	MAX 65 FT	ABOVE 65 FT TO MAX 85 FT	ABOVE 85 FT TO MAX 120 FT	ABOVE 120 FT TO MAX 180 FT	ABOVE 180 FT TO MAX 240 FT	ABOVE 240 FT TO MAX 350 FT	ABOVE 350 FT	MAX 120 FT	
<b>BULK CONTROLS</b>	Max Floor Plate	n/a		15,000 sq ft	12,000 sq ft	10,500 sq ft	12,000 sq ft	12,500 sq ft	50,000 sq ft
	Max Plan Length	n/a		210 ft	140 ft	140 ft	140 ft	145 ft	250 ft
	Max Diagonal	n/a		n/a	170 ft	160 ft	170 ft	175 ft	350 ft
<b>MASSING CONTROLS</b>	Max Apparent Face - Base <sup>1</sup>	30 ft							
	Min Change in Apparent Face - Base <sup>1</sup>	Offset in the horizontal plane of minimum 2 ft depth and 3 ft length OR a major change in fenestration and/or material							
	Max Apparent Face - Above Base <sup>1</sup>	30 ft	100 ft	100 ft	105 ft	100 ft	105 ft	110 ft	250 ft
	Min Change in Apparent Face - Above Base	Offset in the horizontal plane of the building face of minimum 1 ft depth and 1 ft length or a minor change in fenestration and/or material			Offset in the horizontal plane of minimum 10 ft depth and 10 ft length or a major change in fenestration and/or material				
	Upper Floors Step-back <sup>3</sup>	Floors above 55 ft: 20% of floor plate directly below Abutting Mid Block Break: Floors above 35 ft - 1:1.2 plane	Floors above 65 ft: 20% of floor plate directly below Abutting Mid Block Break: Floors above 35 ft - 1:1.2 plane	Floors above 85 ft: 20% of floor plate directly below Abutting Mid Block Break: Floors above 35 ft - 1:1.2 plane	n/a				
	High-rise Shaping	n/a			Additional standards regulating segmentation of the high-rise elevation and floor plan. See Section 4.3.1 A.				n/a
Massing Image <sup>2</sup>									

<sup>1</sup>The base is defined as a minimum of the first 20' in height for low- and mid-rise buildings; and as a minimum of the first 35' in height for high-rise buildings.  
<sup>2</sup>Massing images for high-rise do not show podiums, which are permitted. Refer to Table 4.2 and Section 4.2.3.  
<sup>3</sup>Not applicable in Candlestick Center. Refer to Chapter 5.3 for other design controls for buildings in Candlestick Center.



Precedent – Residential setback provides private open space zone.



Precedent – State Recreation Area setback zone.

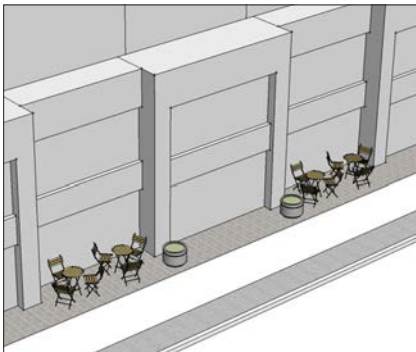

Retail has no setback in order to strengthen the relationship with sidewalk.

## A – Setback

### Intent

A building setback is the minimum required distance between the building face and the property line, or in some cases where buildings face a mid-block break, between the building face and the middle of the mid-block break. Setbacks apply to the ground floor use of a building. Setback zones, where specified, should be used for the purpose of landscaping or for Active Uses such as patios and entrance areas. This D4D calls for extensive setbacks throughout the community affording a comfortable and pleasant pedestrian experience that will be a departure from the development practices of most other San Francisco neighborhoods where buildings typically abut against or are close to the property line.

### Standards

**Residential Setbacks** – A minimum setback of 10 ft to building face is required for residential buildings to allow for the provision of private landscaping and street facing patios and stoops. The setback shall not vary along the predominant wall of a building once established (aside from minor variation which are described in Build-To Percentages).

Exceptions:

1. Residential use that is located above retail use (i.e. mixed-use) may extend to property line.
2. Portions of a residential building that are adjacent to or across the street from a park/open space shall have a minimum setback of 6 ft.
3. The street side of Candlestick South blocks 3 and 5, due to the shallow block depth, shall have a minimum setback of 5 ft.
4. Residential uses within Candlestick Center shall have a zero setback on Harney Way and Ingerson Avenue.
5. Residential frontage along Arelious Walker Drive at Ingerson Avenue shall have a minimum of 30 linear feet of frontage that holds the corner.

**Mixed-Use/Commercial Setbacks** – There are no required setbacks for mixed-use/commercial buildings, except for parking structures, which shall have an 18 inch setback.

For additional guidelines on establishing appropriate setbacks, please refer to Section 4.3.1 Building Types and Section 4.3.2 F Private Open Space.

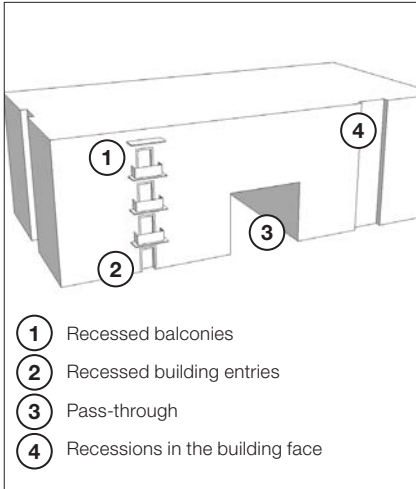

Minor variations excluded from build-to line calculations.



Precedent – Recessed balconies exempted from build-to calculations.



Precedent – Recessed building entrances exempted from build-to calculations.



Precedent – Stepback at top floor.

## B – Build-to Line

### Intent

Build-to Lines are intended to ensure that buildings are situated at or close to setback lines in order to create and maintain defined street walls. Street walls are important in the framing and animation of the public right of way. This framing intent is particularly important, for example, along the two wedge parks illustrated in Figure 3.4. A successful development of street wall will create defined ‘outdoor rooms’ which will invite greater activity of residents and visitors alike.

The Build-to Line is expressed as a minimum percentage of the setback line for building faces that front a public street. For instance, with a 70% Build-to Line, 70% or more of all building faces fronting a public street must be built up to the setback line, and 30% or less of building faces may be built behind the setback line.

### Standards

The Build-to Line standard for residential buildings is 70% and for mixed-use and commercial buildings is 85%.

**Exemptions** – Minor variations excluded from the calculation of the minimum build-to percentage are:

- For retail uses, recesses including entrances, walk-up window or street patio area shall not be allowed on more than 50% of the total frontage of the building and no recess shall be greater than 12 ft in depth.
- Recessed balconies.
- Recessed building entries to a maximum depth of 8 ft.
- Pass-through up to 2 floors in height.
- Recession in the building face for the purpose of building articulation.
- Stepback on the top floor or top two floors.
- Stepback for high-rise sculpting.

## C – Stepback

### Intent

A stepback is that portion of a building that must be stepped back from the setback line. Typically, this is regulated for the upper floor(s) of mid-rise buildings as a means of sculpting their mass.

### Standards

**Upper Floor(s) Stepback** – The upper floor(s) of low and mid-rise buildings above a specified height shall stepback a minimum of 20% of the floor plate of the floor immediately below the specified height. For applicable stepback heights, see Table 4.4, Table 4.6 and Section 5.3.5. Except as otherwise provided, the stepback requirement shall apply to:

- Any floor(s) of a Low Rise Building with a maximum height above 55 ft;
- Any floor(s) of a Mid Rise Building with a maximum height between 65 ft to a maximum of 120 ft; and





Precedent – Bay window projections within setback zone.

- Any floor(s) of a Mid Rise Building with a maximum height between 85 ft to a maximum of 120 ft

Where abutting a Mid-Block Break that is a Pedestrian Mews or Vehicular Laneway, any portion of a low or mid-rise building above 35 ft shall step back at a plane ratio of 1:1.2 (see Table 4.6 and Figure 4.12).

Allowable uses with the stepback roof area include usable open space, landscaping, and railings. Mechanical space is not allowed.

## D – Projection

### Intent

A projection is that portion of a building that projects beyond the main building face. There are a number of types of projections as described below.

### Standards

**Habitable Projections** – Habitable space within a projection means a portion of the building enclosed by walls and a roof. Typically this will be a bay window, corner element, or regularly occurring bay that extends through some or all floors of a building. A habitable space may project 3 ft beyond the building face, either into a setback zone or the public realm. No individual habitable projection may exceed 15 ft in length, except along public streets, where it may be up to 25 ft in length. All projections shall have a minimum clearance to the sidewalk of 9 ft.

**Non-habitable Projections** – non-habitable projections are spaces utilized by residents that are not enclosed by walls and a roof. Non-habitable spaces include all usable balconies, which may extend no more than 6 ft into a setback, or common open space or 3 ft into the public realm. No individual non-habitable projection may exceed 15 ft in length, except along public streets, where it may be up to 25 ft in length. All projections shall have a minimum clearance of 9 ft to the sidewalk.

**Cumulative Projections** – The cumulative total of all types of projections shall not exceed 67% of the building face.

**Other Projections** – Other allowable projections include:

- Decorative elements such as belt courses, cornices, sills and eaves to a maximum 2 ft 6 inches beyond the setback.
- Decks, patios and steps at the first floor of occupancy may project to the property line but not beyond.
- Fences, railings, chimneys, awnings and canopies may project to the property line but not beyond.

- Retail signs, canopies and awnings may project 5 ft beyond property line; a minimum 9 ft vertical clearance to the sidewalk shall be maintained.
- Sustainable elements such as solar shades and wind fins.

**Streetwall Hierarchy** – Streetwall standards follow a hierarchy of street typologies, as defined in Table 4.5 below. Building frontages shall meet the streetwall standards for their addressing frontage.

Table 4.5 Streetwall Hierarchy

HIERARCHY	USE
1	High-rise – Candlestick Center Frame / High-rise – Mixed-Use Residential District / Signature Building
2	Mid-rise – Candlestick Center Frame / Mid-rise – Mixed-Use Residential District
3	Low-rise – Mixed-Use Residential District / Low-rise – CPSRA Edge
4	Mid-block Break – Commercial / Mid-block Break – Pedestrian Mews or Vehicular Laneway / Mid-block Break Pedestrian Mews only

Table 4.6 Street Wall Standards

Building frontages shall meet the streetwall standards for their addressing frontage.

STREET WALL CONDITIONS															
USE	MINIMUM SETBACK (ft)		MINIMUM BUILD-TO LINE (%)		MINIMUM STEPBACK (%)	MAXIMUM PROJECTION (ft)		MINIMUM GROUND-FLOOR HEIGHT RETAIL USE (ft)	MINIMUM AVERAGE RETAIL DEPTH (ft)	MINIMUM RETAIL FENESTRATION (%)	MAXIMUM BUILDING ENTRANCE RECESS (ft)	GRADE SEPARATION ABOVE SIDEWALK (ft)		UNDERGROUND PARKING (ft)	
	Residential Building	Mixed Use or Commercial Building	Residential Building	Mixed Use or Commercial Building		Habitable	Non-Habitable					Residential Ground Floor Unit	Residential Entry or Retail Ground Floor		
A	High-rise – Candlestick Center Frame	n/a	0	n/a	85	n/a	3	6	20	35	60	n/a	n/a	at grade	May be built to property line with minimum 36" soil depth for landscape
B	High-rise – Mixed-Use Residential District	10 <sup>1</sup>	0	70	85	n/a	3	6	15	n/a	n/a	8	2-4	n/a	
C	Signature Building	n/a	0 <sup>6</sup>	n/a	85	n/a	3	6	20	35	60	n/a	n/a	at grade	
D	Mid-rise – Candlestick Center Frame	n/a <sup>10</sup>	0 <sup>7</sup>	70	85	20 <sup>9</sup>	3	6	20 <sup>8</sup>	35	60	n/a	n/a <sup>11</sup>	at grade	
E	Mid-rise – Mixed-Use Residential District	10 <sup>1</sup>	0	70	85	20	3	6	15	n/a	n/a	8	2-4	n/a	
F	Low-rise – Mixed-Use Residential District	10 <sup>1</sup>	0	70 <sup>2</sup>	85	20	3	6	15	n/a	n/a	8	2-4	n/a	
G	Low-rise – CPSRA Edge	30	20	50	85	20	3	6	15	n/a	n/a	8	2-4	n/a	
H	Mid-block Break – Pedestrian Mews or Vehicular Laneway	20 <sup>4</sup>	20 <sup>4</sup>	50	85	ratio <sup>3</sup> 1:1.2	3	6	15	n/a	n/a	n/a	2-4	n/a	

n/a = not applicable or no standard

- <sup>1</sup> When residential building fronts or is located across the street from a park/open space, the minimum setback shall be 6 ft. Candlestick South blocks 3 and 5 shall have a minimum setback of 5 ft.
- <sup>2</sup> Minimum build-to percentage is reduced to 50% for buildings fronting waterfront.
- <sup>3</sup> Building stepback shall be at a line of 1 horizontal to 1.2 vertical above 35 ft height to a maximum of 85 ft, thereafter being permitted to the full allowable height for the zone.
- <sup>4</sup> Setback for mid-block breaks is to be taken from the center line of the mid-block break.
- <sup>5</sup> Non-habitable projections may be a maximum of 6 ft, but may not project into the public realm by more than 3 ft.
- <sup>6</sup> Refer to Section 5.3.4 for standards for corner public plaza to satisfy setback requirements.
- <sup>7</sup> At one location, buildings may setback from Ingerson Avenue or Harney Way up to 45 ft. maximum if a public space adhering to promenade standards in Section 5.3.13 is provided between the building and the street.
- <sup>8</sup> Buildings located along Arelious Walker Drive shall be permitted to have a ground floor height of less than 20ft.
- <sup>9</sup> See Table 4.4, except for residential buildings within Candlestick Center, which shall have no required stepback below 85 ft; and minimum stepback of 10% above 85 ft.
- <sup>10</sup> See Section 4.2.4 A residential setbacks.
- <sup>11</sup> Any ground floor residential unit entrances that occur within interior of Candlestick Center shall have a 2- 4 ft grade separation.



**Uses are defined as follows:**

- A High-rise – Candlestick Center Frame** – High-rise mixed-use buildings with mandatory retail or other commercial uses with a minimum height of 20 ft at ground level, with residential or commercial uses above. Maximum building height per Figure 4.3.
- B High-rise – Mixed-Use Residential District** – High-rise residential buildings, or high-rise mixed-use buildings with limited ground floor retail. Maximum building height per Figure 4.3.
- C Signature Building** – A signature building at Candlestick Center on the corner of Harney Way and Ingerson Avenue. Mandatory retail, commercial or other uses ancillary to the activities within the building with a minimum height of 20 ft shall be provided at ground floor level. Maximum building height is 120 ft.
- D Mid-rise – Candlestick Center Frame** – Mid-rise mixed-use buildings along both sides of Harney Way and Ingerson Avenue at Candlestick Center. Mandatory Active Uses with a minimum height of 20 ft shall be provided at ground level, with residential or other uses above. Along Arelious Walker Drive, a landscaped street frontage and a ground floor height of less than 20 ft are allowed. Maximum building height per Figure 4.3.
- E Mid-rise – Mixed-Use Residential District** – Mid-rise residential buildings, or mixed-use buildings with limited ground floor retail along the western side of Harney Way between Ingerson Avenue and Egbert Avenue. Maximum building height per Figure 4.3.
- F Low-rise – Mixed-Use Residential District** – Low-rise residential buildings, or mixed-use buildings with limited ground floor retail. Maximum building height per Figure 4.3.
- G Low-rise – CPSRA Edge** – Low-rise residential buildings, or mixed-use buildings with limited ground floor retail abutting the eastern boundary of the Candlestick Point State Recreation Area (CSPRA). Maximum building height per Figure 4.3.
- H Mid-block Break – Pedestrian Mews or Vehicular Laneway** – Low-rise or mid-rise residential or mixed use buildings facing a mid-block break that is a pedestrian mews or vehicular laneway. Maximum height at building face shall not exceed 35 ft, after which a stepback is required at a ratio of 1 horizontal to 1.2 vertical to a maximum of 85 ft and thereafter permitted to the full allowable height for the zone. Maximum building height per Figure 4.3.

Figure 4.4 Street Wall Conditions

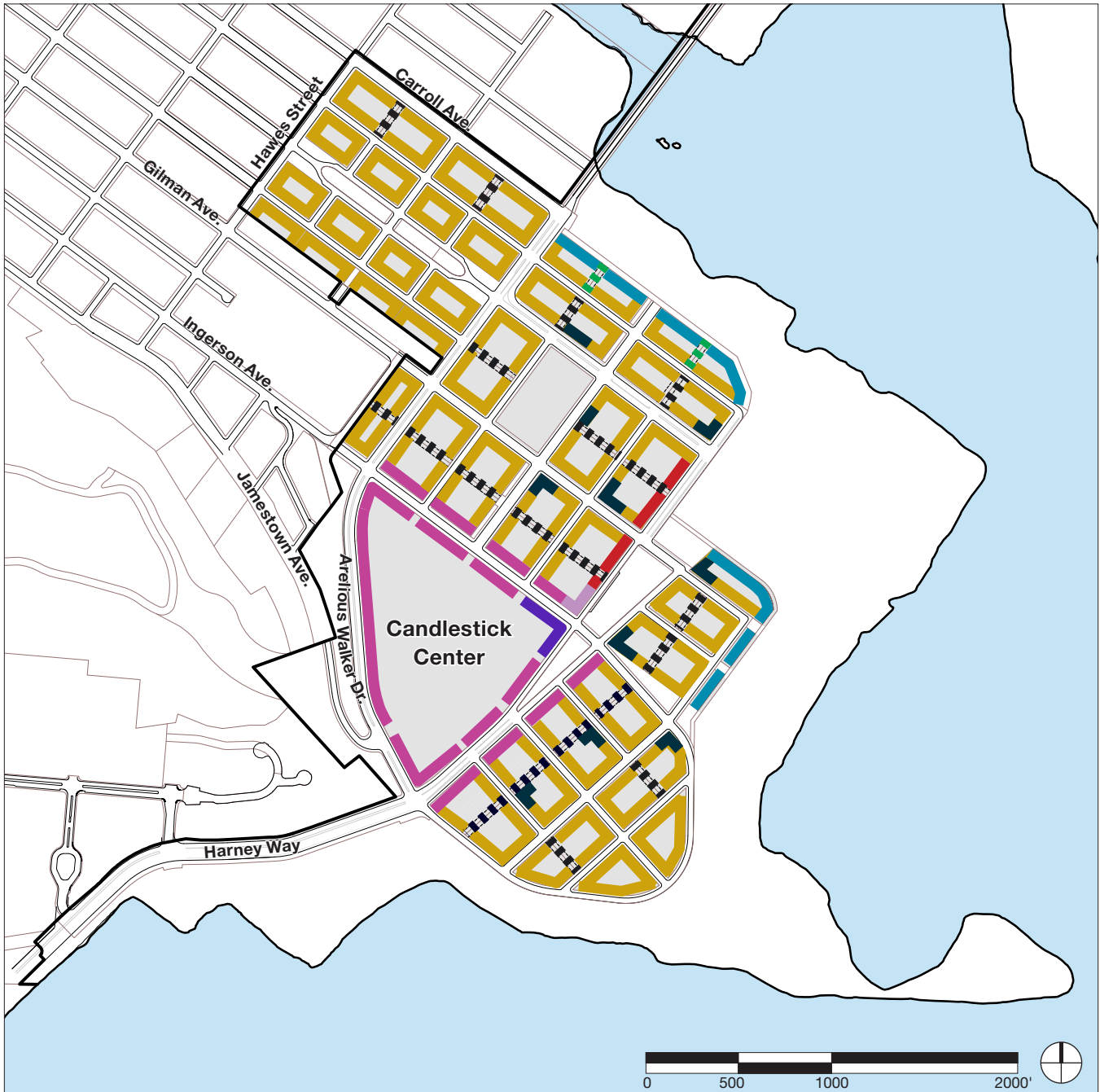

Legend

- |  |   |
|--|---|
| <ul style="list-style-type: none"> <li><span style="display: inline-block; width: 15px; height: 10px; background-color: #d8bfd8; border: 1px solid black; margin-right: 5px;"></span> A. High-rise – Candlestick Center Frame*</li> <li><span style="display: inline-block; width: 15px; height: 10px; background-color: #006400; border: 1px solid black; margin-right: 5px;"></span> B. High-rise – Mixed-Use Residential District*</li> <li><span style="display: inline-block; width: 15px; height: 10px; background-color: #4b0082; border: 1px solid black; margin-right: 5px;"></span> C. Signature Building</li> <li><span style="display: inline-block; width: 15px; height: 10px; background-color: #e91e63; border: 1px solid black; margin-right: 5px;"></span> D. Mid-rise – Candlestick Center Frame</li> <li><span style="display: inline-block; width: 15px; height: 10px; background-color: #ff0000; border: 1px solid black; margin-right: 5px;"></span> E. Mid-rise – Mixed-Use Residential District</li> </ul> | <ul style="list-style-type: none"> <li><span style="display: inline-block; width: 15px; height: 10px; background-color: #ffd700; border: 1px solid black; margin-right: 5px;"></span> F. Low-rise – Mixed-Use Residential District</li> <li><span style="display: inline-block; width: 15px; height: 10px; background-color: #008080; border: 1px solid black; margin-right: 5px;"></span> G. Low-rise – CPSRA Edge</li> <li><span style="display: inline-block; width: 15px; border-bottom: 2px dashed black; margin-right: 5px;"></span> H. Mid-block Break – Pedestrian Mews or Vehicular Laneway</li> <li><span style="display: inline-block; width: 15px; border-bottom: 2px dashed green; margin-right: 5px;"></span> Mid-block Break – Pedestrian Mews only</li> </ul> |
|--|---|

Notes: \* See Section 4.2.1 for allowable location zones for high-rise.

For Private Streets and Paseos within Candlestick Center, see Sections 5.3.3, 5.3.6 and 5.3.11.



Figure 4.5 A. High-rise – Candlestick Center Frame

**SETBACK** – No standard.

**BUILD TO LINE** – Minimum 85% shall be built to the property line.

**STEPBACK** – No standard. Other high-rise shaping standards are contained in Section 4.3.2.

**PROJECTION** – Habitable Space: Maximum 3 ft. Non-Habitable: Maximum 6 ft (Maximum 3 ft into public realm).

**GROUND FLOOR RETAIL: HEIGHT, DEPTH & FENESTRATION** – Where applicable, a ground floor commercial (retail) use is to have a minimum floor-to-floor height of 20 ft. and a minimum average depth of 35 ft. Provide at least 60% fenestration to full height.

**BUILDING ENTRANCE** – No standard.

**GRADE SEPARATION** – Retail grade must meet the grade of the adjacent sidewalk.

**U/G PARKING** – May be built to the property line provided a minimum of 36 inch soil depth maintained where landscape is provided.

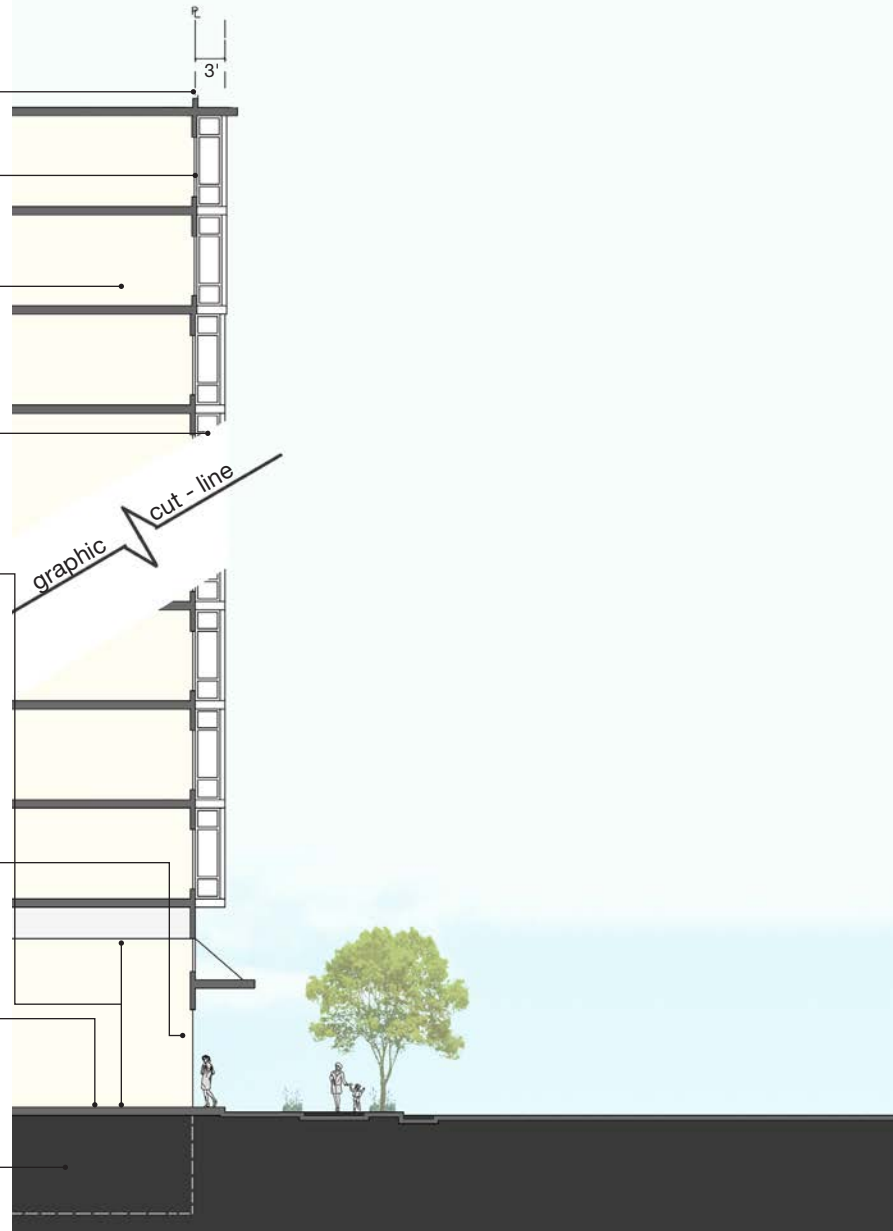



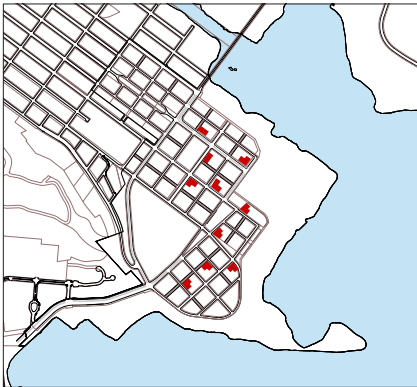

Figure 4.6 B. High-rise – Mixed-Use Residential District

**SETBACK** – Residential Building – Building face shall be set back 10 ft from the property line. Patio may extend to the property line. Mixed Use / Commercial Building – There is no setback.

**BUILD TO LINE** – Residential Building – Minimum 70% of building face must be built to setback line. Mixed Use or Commercial Building – Minimum 85% of building face must be built to setback line.

**STEPBACK** – No standard. Other high-rise shaping standards are contained in Section 4.3.1.

**PROJECTION** – Habitable Space: Maximum 3 ft. Non-Habitable: Maximum 6 ft (Maximum 3 ft into public realm).

**GROUND FLOOR HEIGHT** – Where applicable, a ground floor commercial use is to have a minimum floor-to-floor height of 15 ft.

**BUILDING ENTRANCE** – Maximum 8 ft recess.

**GRADE SEPARATION** – Units must be 2 ft to 4 ft above street; main building entry may be at street level.

**U/G PARKING** – May be built to the property line provided a minimum of 36 inch soil depth maintained where landscape is provided.

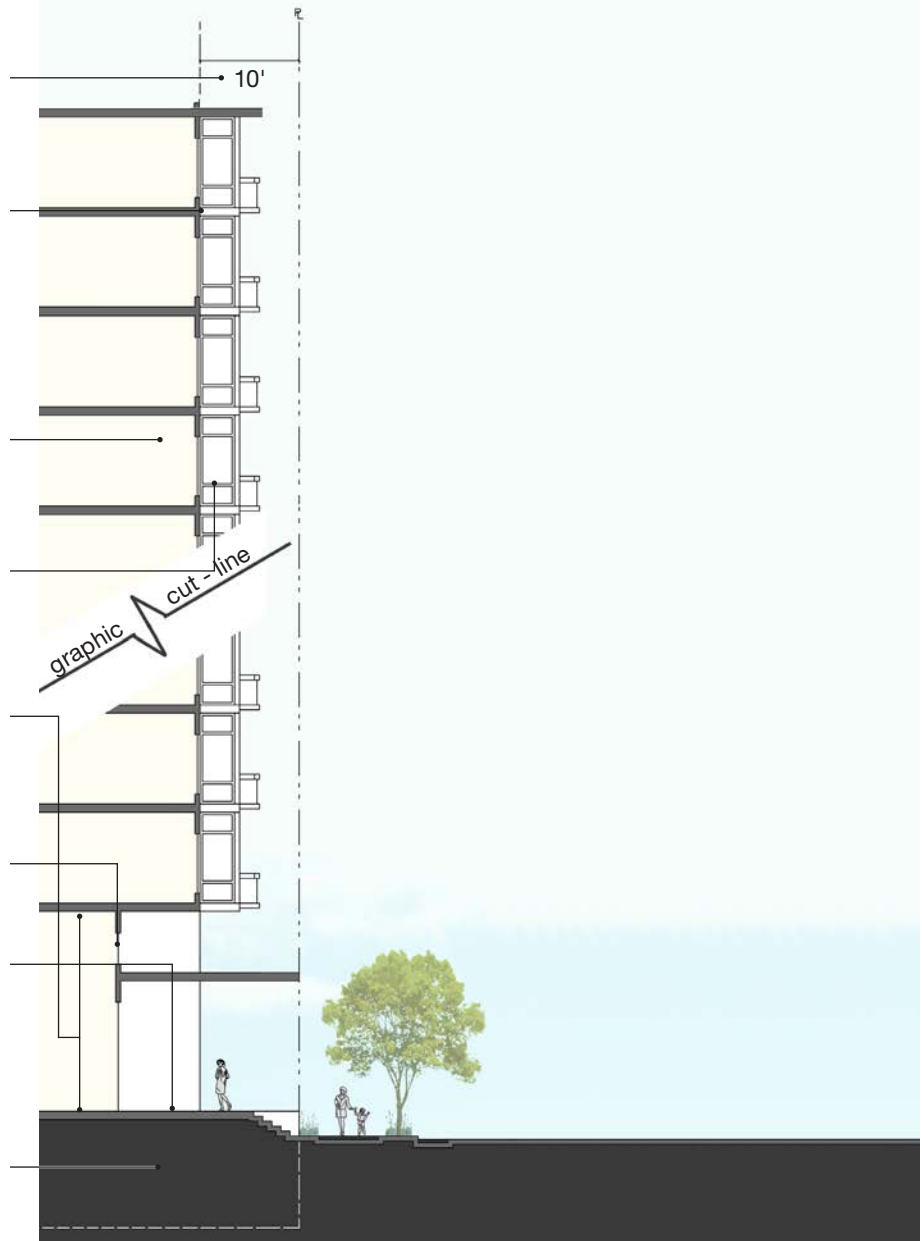



Figure 4.7 C. Signature Building

**SETBACK** – No standard.

**BUILD TO LINE** – Minimum 85% of building face must be built to property line.

**STEPBACK** – No standard.

**PROJECTION** – Habitable Space: Maximum 3 ft. Non-Habitable: Maximum 6 ft (Maximum 3 ft into public realm).

**GROUND FLOOR RETAIL: HEIGHT, DEPTH & FENESTRATION** – Where applicable, a ground floor commercial (retail) use is to have a minimum floor-to-floor height of 20 ft. and a minimum average depth of 35 ft. Provide at least 60% fenestration to full height.

**BUILDING ENTRANCE** – No standard.

**GRADE SEPARATION** – Retail and lobby grade must meet the grade of the adjacent sidewalk.

**U/G PARKING** – May be built to the property line provided a minimum of 36 inch soil depth maintained where landscape is provided.

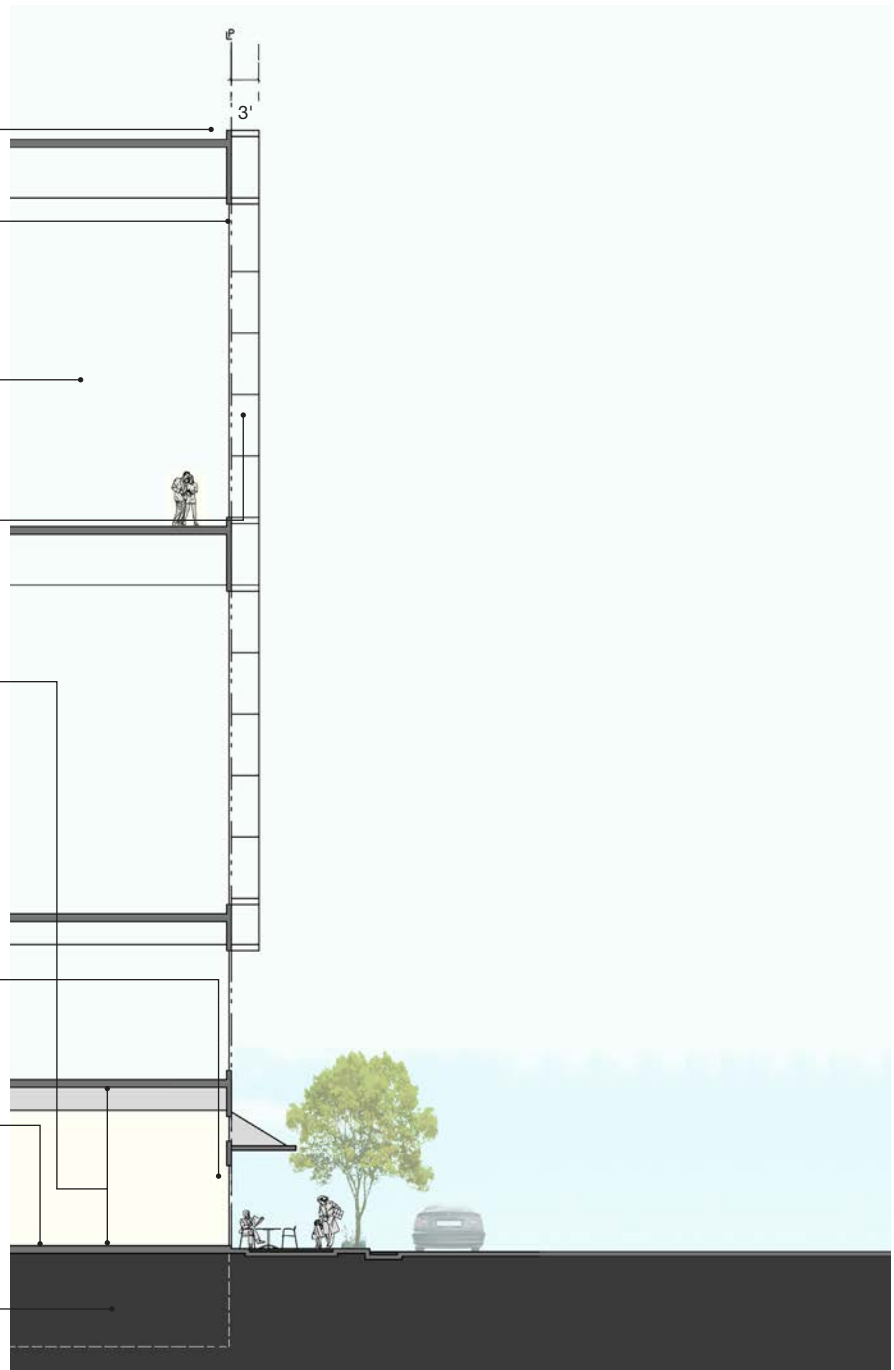

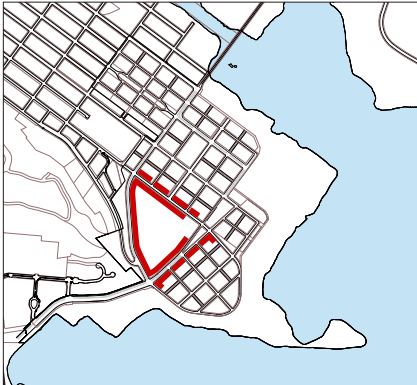

Figure 4.8 D. Mid-rise – Candlestick Center Frame

**SETBACK** – No standard.

**BUILD TO LINE** – Mixed Use / Commercial Building – Minimum 85% shall be built to the property line.

**STEPBACK** – Building footprint shall step back 20% in size above 65 ft, except in Candlestick Center (see Table 4.4. and 4.6).

**PROJECTION** – Habitable Space: Maximum 3 ft. Non-Habitable: Maximum 6 ft (Maximum 3 ft into public realm).

**GROUND FLOOR RETAIL: HEIGHT, DEPTH & FENESTRATION**– Where applicable, a ground floor commercial (retail) use is to have a minimum floor-to-floor height of 20 ft. and a minimum average depth of 35 ft. Provide at least 60% fenestration to full height.

**BUILDING ENTRANCE** – No standard.

**EXCEPTION FOR OFFICE BUILDINGS AND RETAIL BUILDINGS** – Within Candlestick Center, all commercial office buildings that are between 85' - 120' in height, shall stepback a minimum of 20% at the top floor if average floor to floor height is more than or equal to 15', or shall stepback a minimum of 20% at the top two floors if average floor to floor height is less than 15'.

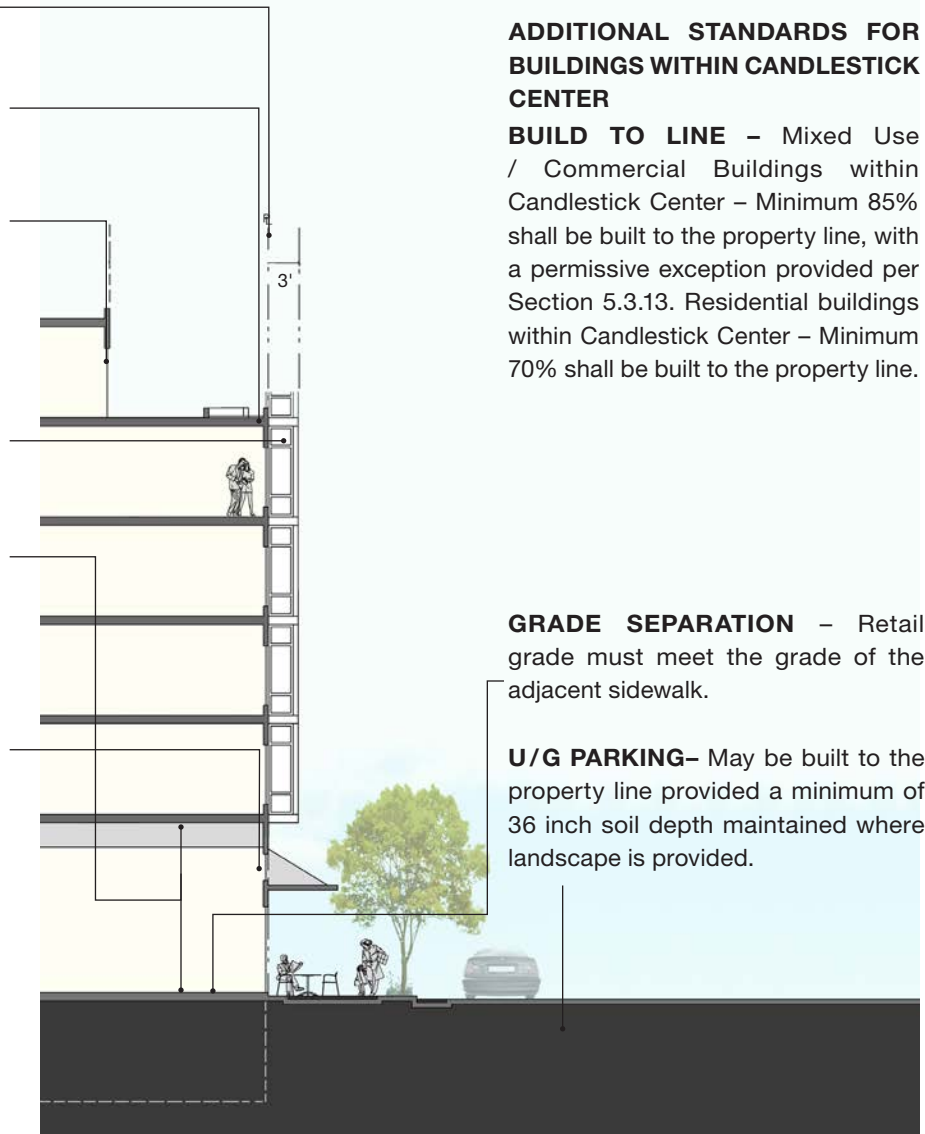

**ADDITIONAL STANDARDS FOR BUILDINGS WITHIN CANDLESTICK CENTER**

**BUILD TO LINE** – Mixed Use / Commercial Buildings within Candlestick Center – Minimum 85% shall be built to the property line, with a permissive exception provided per Section 5.3.13. Residential buildings within Candlestick Center – Minimum 70% shall be built to the property line.

**GRADE SEPARATION** – Retail grade must meet the grade of the adjacent sidewalk.

**U/G PARKING**– May be built to the property line provided a minimum of 36 inch soil depth maintained where landscape is provided.





Figure 4.9 E. Mid-rise – Mixed-Use Residential District

**SETBACK** – Residential Building – Building face must be setback 10 ft from property line. Patio and underground parking may extend to property line. Mixed Use / Commercial Building – There is no setback.

**BUILD TO LINE** – Residential Building – Minimum 70% of building to 65 ft height must be built to setback line. Mixed Use or Commercial Building – Minimum 85% of building for the first 65 ft of height must be built to setback line.

**STEPBACK** – Building floor plate shall stepback 20%: Above 65 ft for buildings to 85 ft height.

**PROJECTION** – Habitable Space: Maximum 3 ft. Non-Habitable: Maximum 6 ft (Maximum 3 ft into public realm).

**GROUND FLOOR HEIGHT** – Where applicable, a ground floor commercial use is to have a minimum floor-to-floor height of 15 ft.

**BUILDING ENTRANCE** – Maximum 8 ft recess.

**GRADE SEPARATION** – Ground floor units must be 2 ft to 4 ft above street; main building entry may be at street level.

**U/G PARKING** – May be built to the property line provided a minimum of 36 inch soil depth maintained where landscape is provided.

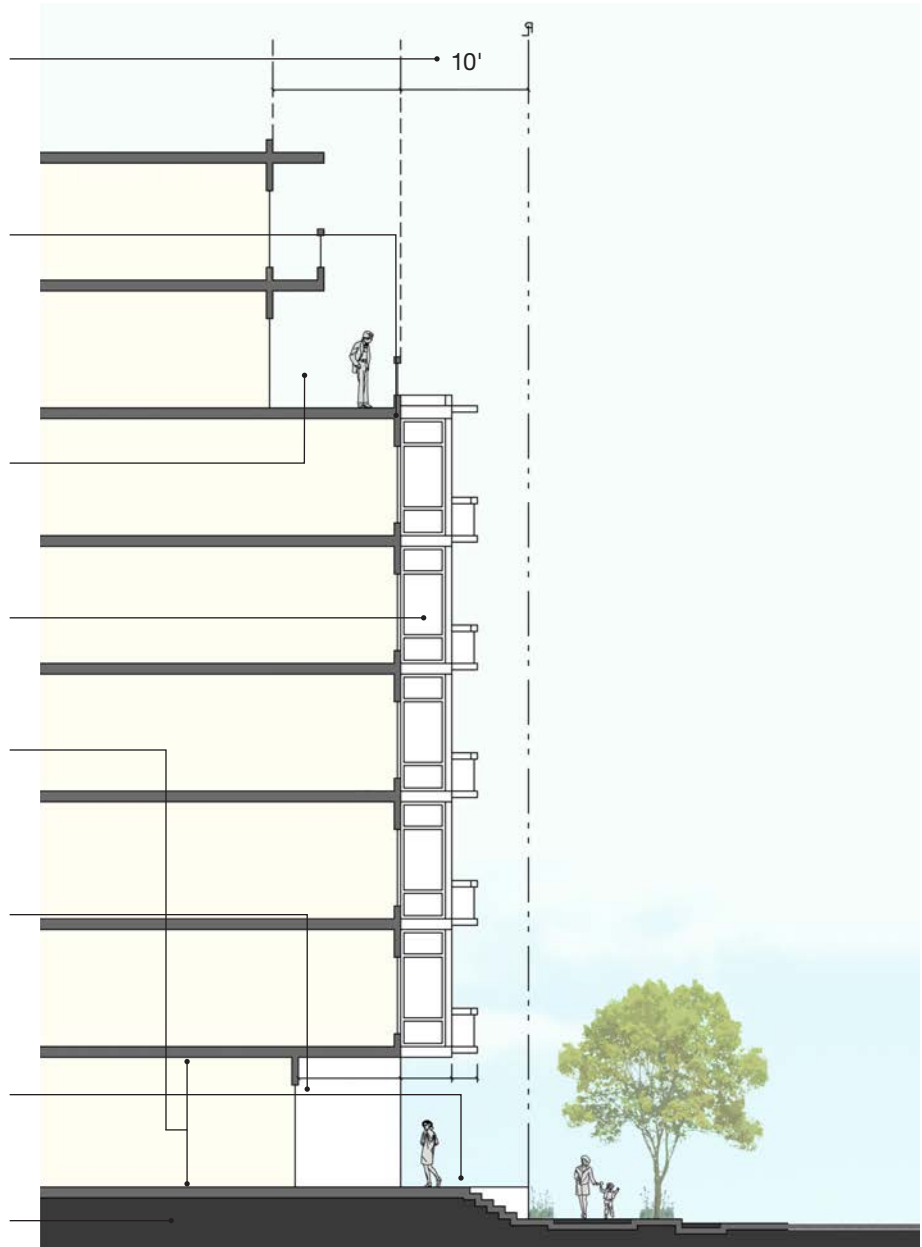

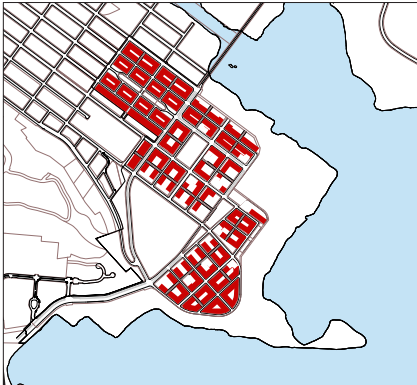

Figure 4.10 F. Low-rise – Mixed-Use Residential District

**SETBACK** – Residential Building – Building face must be set back 10 ft from the property line (see Table 4.7 for exceptions). Patio and underground parking may extend to the property line. Mixed Use / Commercial Building – There is no setback.

**BUILD TO LINE** – Residential Building – Minimum 70% of building for the first 40 ft of height must be built to setback line. Mixed Use / Commercial Building – Minimum 85% of building for the first 40 ft of height must be built to setback line.

**STEPBACK** – Building floor plate shall stepback 20% in size above 55 ft height.

**PROJECTION** – Habitable Space: Maximum 3 ft. Non-Habitable: Maximum 6 ft (Maximum 3 ft into public realm).

**GROUND FLOOR HEIGHT** – Where applicable, a ground floor commercial use is to have a minimum floor-to-floor height of 15 ft.

**BUILDING ENTRANCE** – Maximum 8 ft recess.

**GRADE SEPARATION** – Ground floor units must be 2 ft to 4 ft above street; main building entry may be at street level.

**U/G PARKING** – May be built to the property line provided a minimum of 36 inch soil depth maintained where landscape is provided.

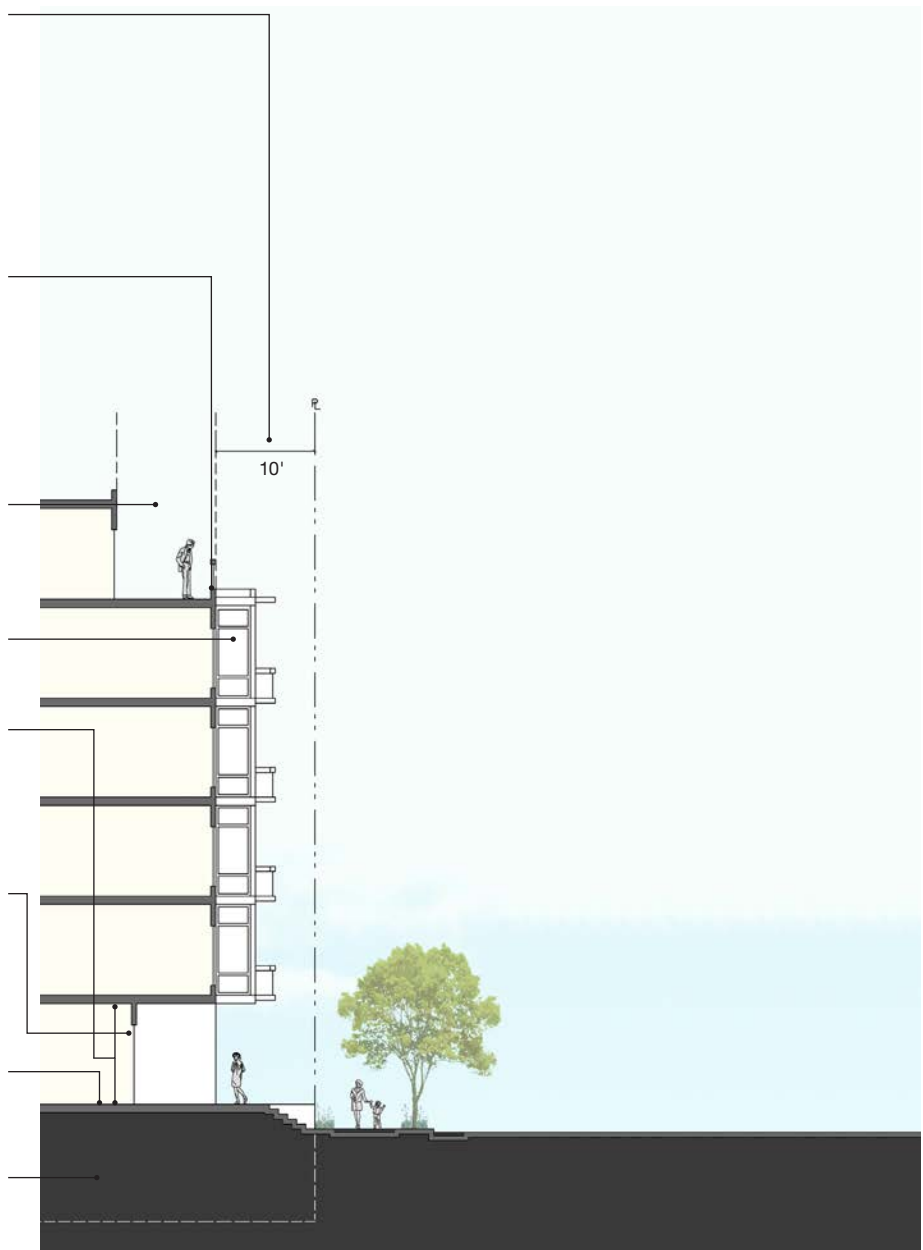

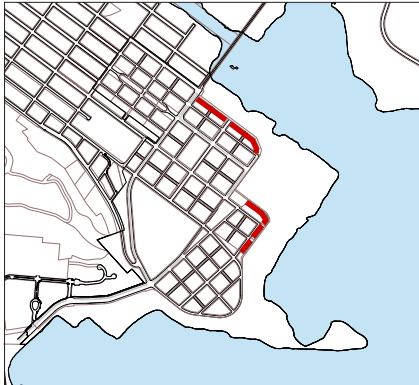

Figure 4.11 G. Low-rise – CPSRA Edge

**SETBACK** – Residential Building – Building shall be set back 30 ft from the property line. Patio and other private landscaping may extend 10 ft into setback. Mixed Use / Commercial Building – Building shall be set back 20 ft from the property line.

**STEPBACK** – Building floor plate shall stepback 20% above 55 ft height.

**PROJECTION** – Habitable Space: Maximum 3 ft. Non-Habitable: Maximum 6 ft (Maximum 3 ft into public realm).

**GROUND FLOOR HEIGHT** – Where applicable, a ground floor commercial use is to have a minimum floor-to-floor height of 15 ft.

**BUILDING ENTRANCE** – Maximum 8 ft recess.

**GRADE SEPARATION** – Residential units must be 2 ft to 4 ft above path; main building entry may be at street level.

**U/G PARKING** – May be built to the property line provided a minimum of 36 inch soil depth maintained where landscape is provided.

**CPSRA CYCLE TRACK EDGE** – Edge treatment along Candlestick North includes a separated cycle track and pedestrian sidewalk. All standards pertaining to buildings and private setbacks set forth above shall apply.

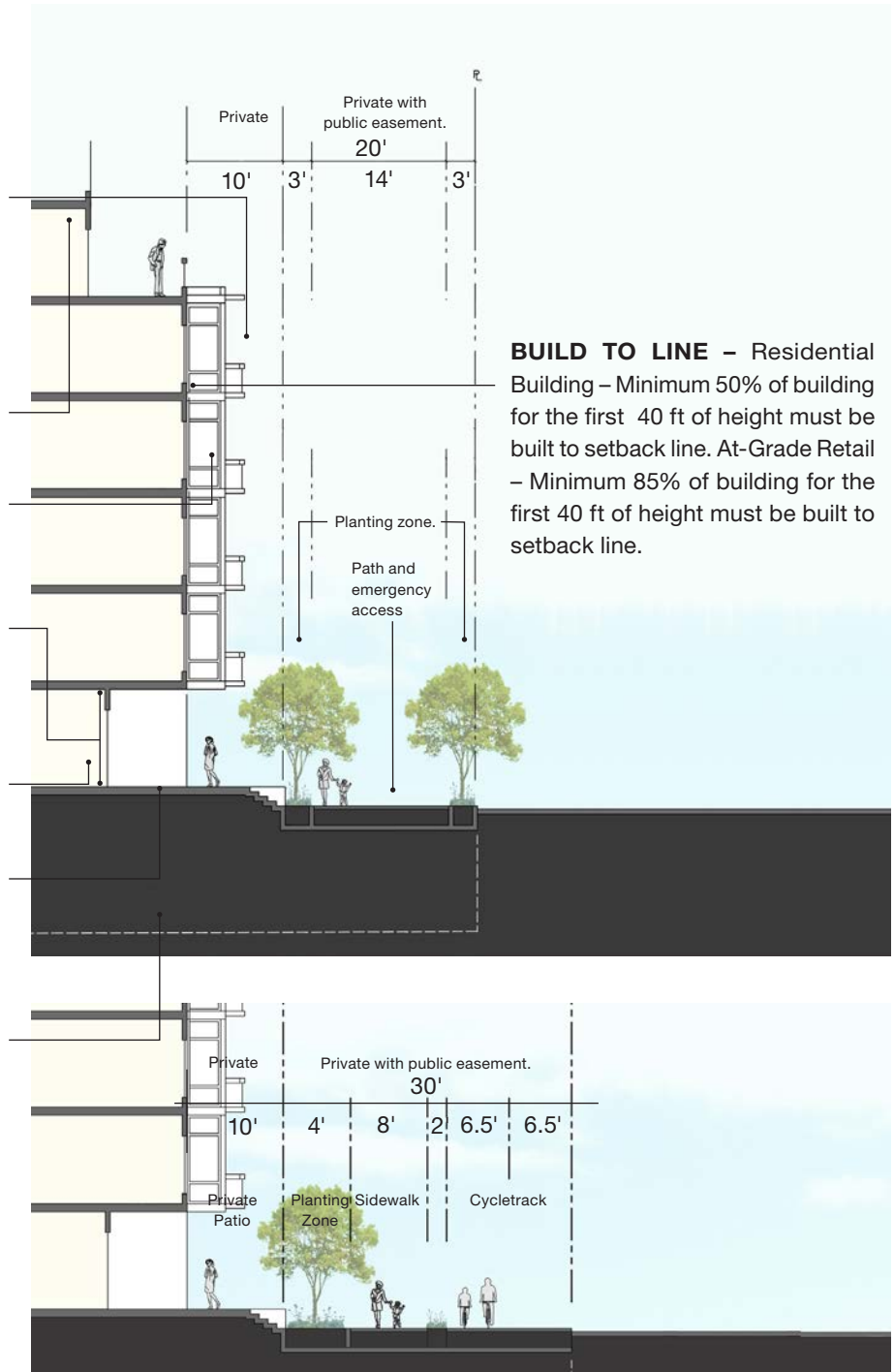

**BUILD TO LINE** – Residential Building – Minimum 50% of building for the first 40 ft of height must be built to setback line. At-Grade Retail – Minimum 85% of building for the first 40 ft of height must be built to setback line.



**PAGE LEFT INTENTIONALLY BLANK**

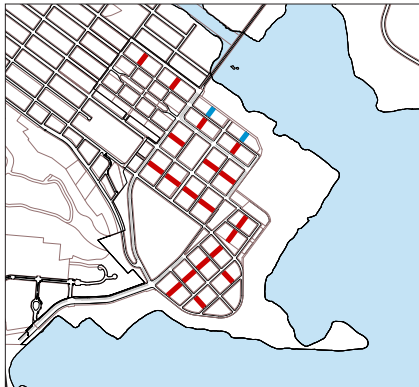

— Mews only    — Mews or Laneway

Figure 4.12 H. Mid-block Break – Pedestrian Mews or Vehicular Laneway

**SETBACK** – Building face must be setback 20 ft from center line of mid-block break.

**BUILD TO LINE** – 50% of building face must be built to setback line. Mixed Use or Commercial Building – Minimum 85% of building face must be built to setback line.

**STEPBACK** – Building shall step back at a plane of 1 : 1.2 above 35 ft height to a maximum of 85 ft height after which the height may be the maximum permitted for the zone.

**PROJECTION** – Habitable Space: Maximum 3 ft. Non-Habitable: Maximum 6 ft (Maximum 3 ft into public realm).

**GROUND FLOOR HEIGHT** – Where applicable, a ground floor commercial use is to have a minimum floor-to-floor height of 15 ft.

**BUILDING ENTRANCE** – No standard.

**GRADE SEPARATION** – Units must be 2 ft to 4 ft above the pathway if fronting a pedestrian mews.

**U/G PARKING** – May be built to the property line provided a minimum of 36 inch soil depth maintained where landscape is provided.

**VEHICULAR LANEWAY STANDARDS**  
All standards for pedestrian mews set forth above shall apply to vehicular laneway, except there is no required separation.

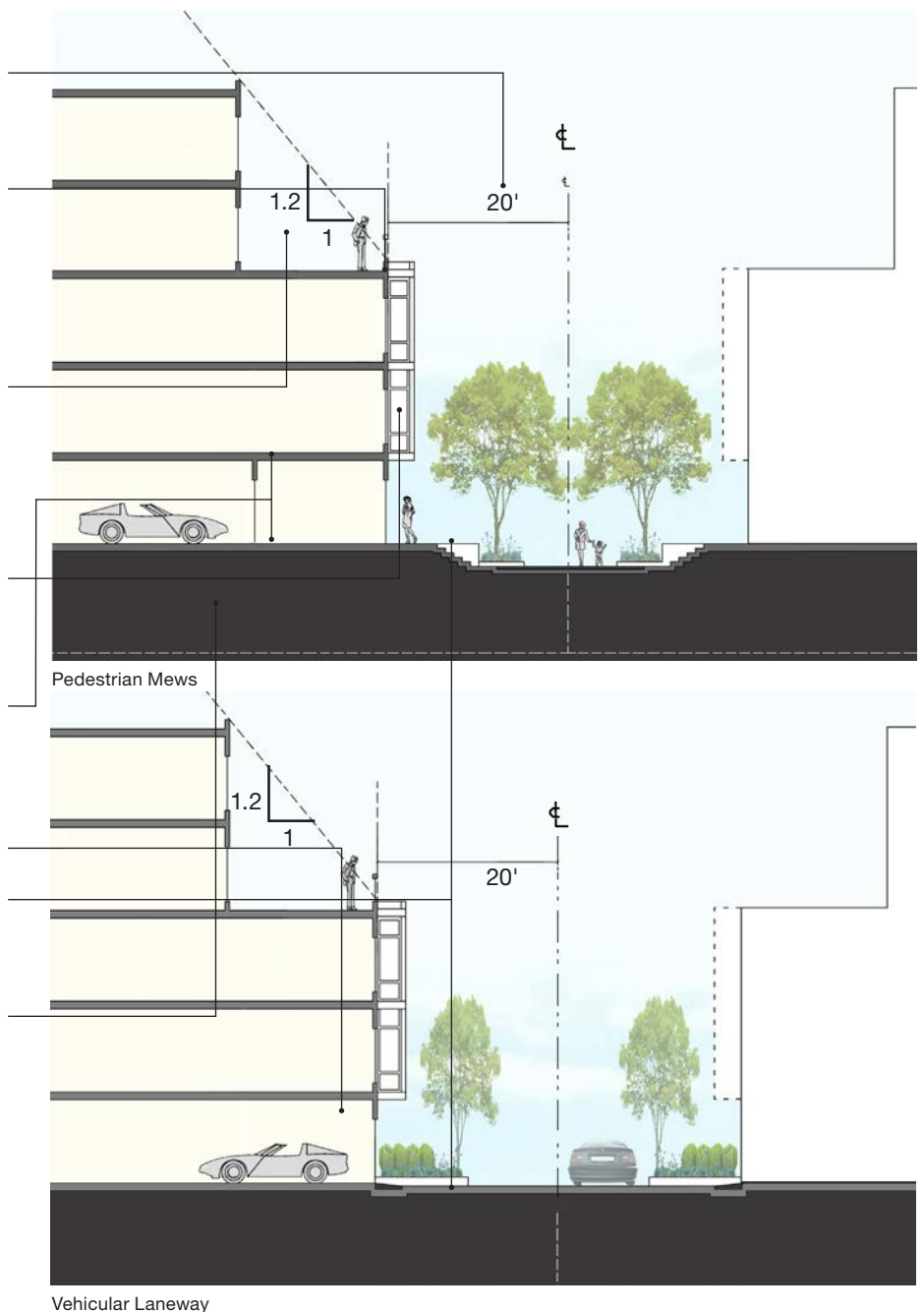

**PAGE LEFT INTENTIONALLY BLANK**



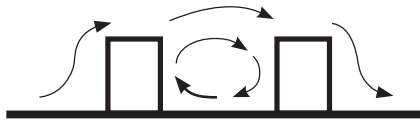

Wind flows in street canyon.

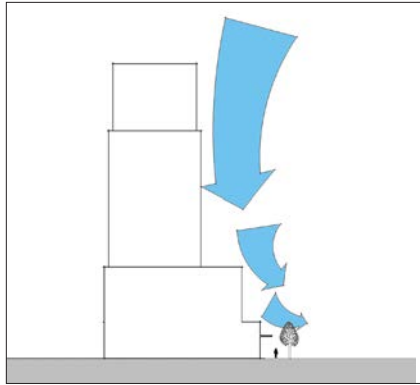

Podium, canopy and street trees deflect winds.

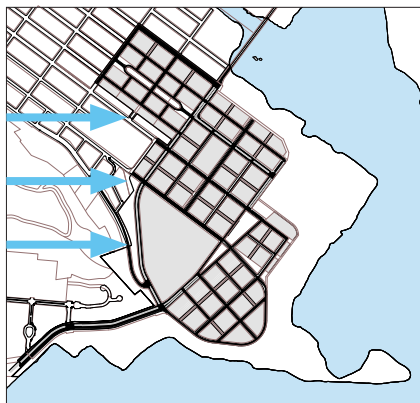

Street and block oriented at 45° to prevailing winds.

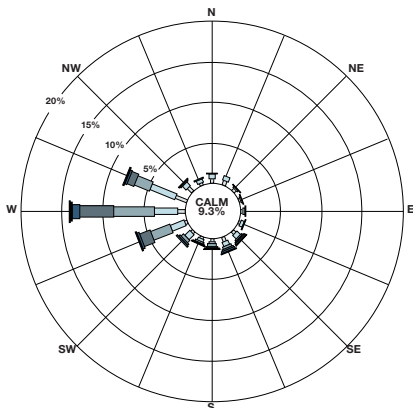

**Legend**

3 – 7 mph	19 – 24 mph
8 – 12 mph	25 – 31 mph
13 – 18 mph	> 32 mph

Hunters Point Naval Shipyard Anemometer – Indicates the direction and intensity of prevailing winds at the site.

## 4.2.5 Wind

### Intent

The effects of the prevailing westerly winds should be mitigated by careful orientation of streets and blocks, and by specific building strategies.

### Standards

**Building Design Wind Analysis** – Prior to design approval of towers with a height of 100 ft or greater, or where recommended by the Agency, the Applicant shall retain a qualified wind consultant to provide a wind review to determine if the exposure, massing, and orientation of the building would result in wind impacts that could exceed the threshold of 26-mph-equivalent wind speed for a single hour during the year. The wind analysis shall be conducted to assess wind conditions for the proposed building(s) in conjunction with the anticipated pattern of development on surrounding blocks to determine if the Project building(s) would cause an exceedance of the wind hazard standard. The analysis shall be conducted as directed by the City’s wind study guidelines, including, if required, wind tunnel modeling of potential adverse effects relating to hazardous wind conditions.

The Agency shall require the Applicant to identify design changes that would mitigate the adverse wind conditions to below the threshold of 26-mph-equivalent wind speed for a single hour of the year. These design changes could include, but are not limited to, wind-mitigating features, such as placing towers on podiums with a minimum 15 ft setback from street edges, placement of awnings on building frontages, street and frontage plantings, articulation of building façades, or the use of a variety of architectural materials.

### Guidelines

**Street and Block Orientation** – Streets and blocks in the plan have been oriented close to 45 degrees from the prevailing wind direction in order to mitigate ‘wind tunnel’ funneling. This strategy has been employed as illustrated.

**Pedestrian Zones** – Pedestrian zones and other outdoor open spaces should be sheltered locations wherever possible.

**Street Level** – At the street level awnings and street trees should be encouraged in order to disrupt and reduce wind flows, particularly important in retail or café patio locations.

**Tower Block Location** – Staggered tower locations are preferable to aligned tower locations in order to reduce funneling.

**Tower Alignment** – Towers should not be aligned parallel to the prevailing wind direction.

**Building Shape** – Taller buildings should be designed to mitigate ‘downwash’ effects. Design features include rounded and/or complex geometry, a bustle/buttress (low or mid-rise extension at base of tower), and podiums.

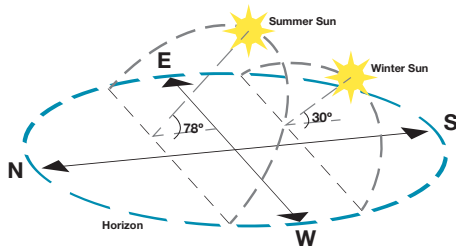

Sun path for Candlestick.

## 4.2.6 Sunlight/Shade

### Intent

Parks and open space should have significant solar access. Buildings should be oriented and designed to mitigate solar heat gain.

### Standards

**High-rise Buildings** – All proposed high-rise developments have been subject to a shadow analysis within the EIR in which certain towers cast shadows on Gilman Park and/or Bayview Hill Park. Should the San Francisco Recreation and Park Department not approve shadowing on one or both parks, a subsequent shadow analysis shall be required to determine maximum no-shadow height of non-conforming towers.

### Guidelines

**Park Shadowing** – In order to minimize shadowing, the angle and direction of the sun should be a significant consideration in the placement and orientation of taller buildings. Taller buildings should be held back wherever possible from significant public parks, to avoid shadowing at times of day when parks are most used.

**Building Shadowing** – To reduce shadowing of adjacent buildings and associated open spaces, taller buildings should be located to the north of shorter buildings wherever possible.

### Heat Gain Mitigation

- Shading strategies – To reduce solar heat gain in buildings, sun shading strategies should be employed for west and south facing façades.
- Orientation – Where possible, buildings should be aligned in a generally east/west direction. Given that the goals of wind mitigation and connection to the existing street grid have strongly influenced the 45 degree orientation of the street and block alignment (which in turn influences building alignment), it may not be possible to achieve optimum solar alignment in all cases.

---

## 4.3 Building Design

The standards and guidelines pertaining to building design and the mechanisms that will promote a positive built environment are contained in this section. It begins with the standards and guidelines that apply to the various building types by use, serving as a basis for differentiating buildings and creating variations in character within the neighborhoods. Following, there are standards and guidelines that apply to the general building elements for all building types within the development.

This section is organized as follows:

### 4.3.1 Building Types

- A Residential
  - Low-Rise
  - Mid-Rise
  - High-Rise
  
- B Commercial
  - Retail and Mixed Use
  - Office
  - Signature Building
  - Hotel
  
- C Other
  - Community Use
  - Park Buildings
  
- D Parking Facilities

### 4.3.2 General Building Elements

- A Base Activation
- B Façade Articulation
- C Materials and Colors
- D Corners
- E Roofs
- F Private Open Space
- G Sustainable Features
- H Building Lighting



### 4.3.1 Building Types

A variety of building types serving a range of functions are incorporated into the plan, as follows:

#### A – Residential

- Low-rise
- Mid-rise
- High-rise

#### B – Commercial

- Retail and Mixed Use
- Office
- Signature Building
- Hotel

#### C – Other

- Community-use
- Park Buildings

#### D – Parking Facilities

Additional development standards for office, parking, residential, and retail buildings in Candlestick Center are in Section 5.3.



Precedent – Residential low-rise building.



Precedent – Residential mid-rise building.



Precedent – Residential high-rise building.



Precedent – Mixed-use building: retail with residential above.



Precedent – Mixed-use building: retail with office above.



Precedent – Performance Center.



Precedent – Low-rise, tuck-under townhomes.



Precedent – Low-rise, liner townhomes.



Precedent – Low-rise, stacked units.



Precedent – Mid-rise.



Precedent – High-rise.

## A – Residential : General

### Intent

Several key characteristics of residential buildings will differentiate Candlestick from many San Francisco neighborhoods. In particular, the lower floors of residential buildings are intended to engage the street by having activated ground floor uses and lush landscaping in setbacks, helping to animate the streets and create a vibrant pedestrian oriented neighborhood.

A variety of residential building types are proposed to structure and define development that include:

- Low-rise – tuck-under townhomes.
- Low-rise – free-standing units with individual garages or shared underground parking.
- Low-rise – liner townhomes that are located at the face of the building and have shared podium or underground podium parking.
- Low-rise buildings to a maximum of 65 ft height with shared corridors and vertical circulation.
- Mid-rise buildings to a maximum of 120 ft\* height with shared corridors and vertical circulation.
- High-rise buildings to a maximum of 420 ft height with shared corridors and vertical circulation.

These types control the intensity and form of development while allowing some flexibility for how buildings are used and how they evolve over time. Within blocks, several building types may be combined, thus creating diverse characteristics throughout the neighborhoods. Ground floor uses for all building types other than townhomes include residential units, live/work units, retail, or office space depending on location and subject to entitlement limitations.

### Standards

**Ground Floor Unit Entrances** – Ground floor units fronting public streets, parks, or along pedestrian mews shall have an access point along the fronting building face in addition to the main access from interior corridor, lobby, or parking structure. Entrances shall occur at intervals no greater than 30 ft, and may be ganged together. Paseos do not constitute public streets or pedestrian mews.

**Grade Separation** – Ground floor units shall be elevated above the street for privacy as more specifically described in Table 4.6.



Residential setback allows for patio zone.



Precedent – Townhome garage entrance.



Precedent – Residential courtyards accessible from public streets.

## A – Residential : Low-Rise / Mid-Rise

### Intent

Both low-rise and mid-rise building types should be designed to ensure visual interest from the street through changes in plane and a fine attention to architectural detail.

Low-rise buildings are the most common building type in the development, and thus have a profound effect on the streetscape. Care should be taken to ensure buildings engage the street, and are visually interesting on upper floors.

Mid-rise buildings are planned in strategic locations in order to emphasize and frame important spaces.

### Standards

**Townhome Garages** – Street fronting townhome garages are prohibited on public streets, except for Candlestick South blocks 3 and 5. Any townhomes that incorporate garages along a mid-block break, as well as those townhomes on Candlestick South blocks 3 and 5, shall engage the mid-block break /street with design characteristics to limit the visual presence of garage doors, emphasizing the garage as secondary to the main entrance and front yard. The maximum number of garage doors per unit is one with a maximum width of 8 ft. Side-by-side garages are prohibited.

**Harney/Ingerson Residential Base Activation within Candlestick Center** – See activation standards in Section 5.3.8.

### Guidelines

**Freestanding Townhome Form ('Tuck-under')** – Freestanding townhomes may be designed with individual character, or in a consistent style. Modular rhythm should be emphasized through the use of common elements such as bay windows, door recesses materials and fenestration. Variety in form at the pedestrian level is encouraged. Townhomes that form the base of a multi-story building should have elements and proportions that tie them to the building above.

**Residential Courtyards** – Residential courtyards that may be accessed or at least viewed from public streets and mews are encouraged.





Precedent – Elevation segmentation of primary and secondary planes.



Precedent – Primary plane of tower extends to full height.

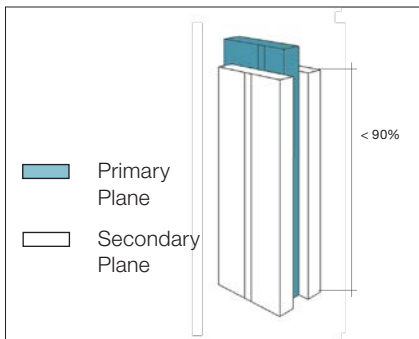

Secondary plane no taller than 90% of primary plane for towers above 300 ft.

## A – Residential High-rise (Tower)

### Intent

Towers are meant to punctuate the low and mid-rise skyline at important locations. As individual buildings, they should be seen as slender and vertical planes whose proportion and detailing creates an elegant and simple composition.

The tower standards and guidelines are intended to demonstrate design possibilities within a basic framework. This approach will encourage a rich variety of buildings, while ensuring that towers are graceful beacons that contribute to the built form of the community.

### Standards

**Elevation segmentation** – Towers should be conceived as vertical planes that are extrusions of the floor plates. There shall be a primary and a secondary plane. Both shall be generally unbroken in order to accentuate the verticality of the tower. For towers over 300 ft height, the primary plane shall be unbroken for the entire height of the tower, and the secondary plane(s) shall be subordinate in height so that the tower has a clearly defined top and does not have an overbearing mass.

Towers over 300 ft height shall have a minimum of two vertical planes, primary and secondary. The size of the primary plane shall be no more than 2/3's and no less than 1/3 of the full floor plate size (ie for a floor plate of 12,500 sq ft, the primary plane shall be between 4,200 sq ft and 8,350 sq ft). The primary plane shall be the full height of the tower. The secondary plane(s) shall be no taller than 90% of the height of the primary plane.

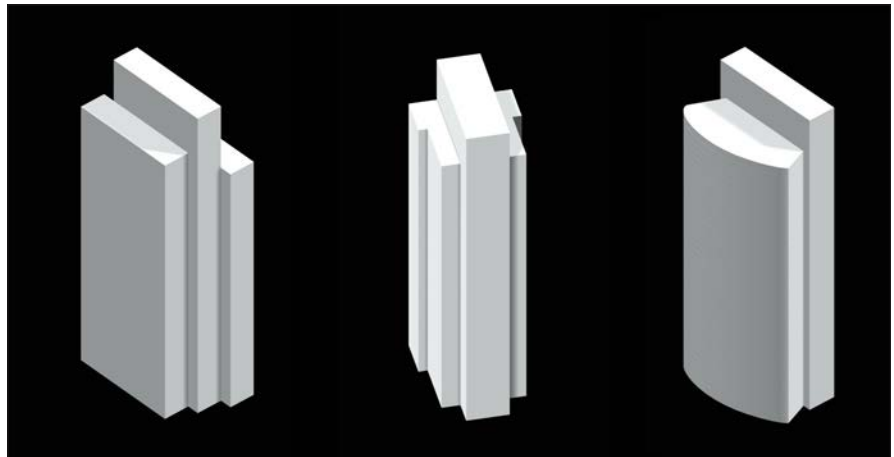

Elevation segmentation – Various examples.



Precedent – Distinct breaks in floor plans reduce apparent façade.

**Floor plan segmentation** – The edges of tower floor plans shall be broken into segments in order to more finely articulate the basic vertical form and avoid monolithic buildings that are out of proportion with the community’s finely scaled buildings. Within these divisions there can be subdivisions to respond to specific unit layouts; however, simpler forms are encouraged. Segmentation can be in either symmetrical or non-symmetrical fashion.

Both the long and the short side of floor plates shall have a minimum of two segments and no segment shall exceed the maximum permitted apparent face (100 – 110 ft, depending on tower height, see Table 4.4 for specific requirements).

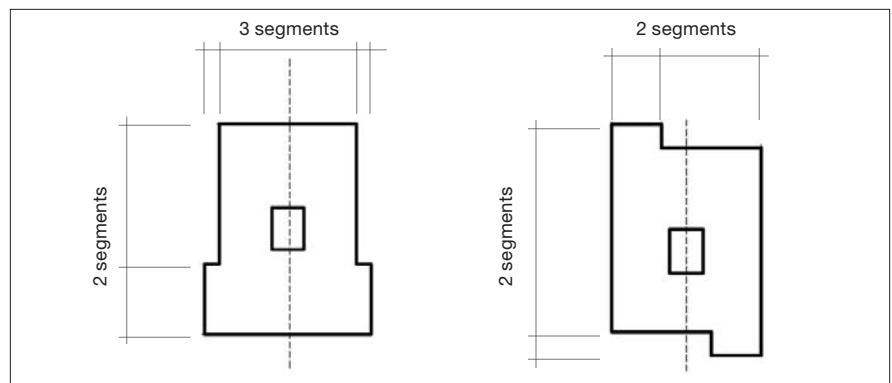

Floor plate segmentation – minimum two segments.



Precedent – Floor plan segmentation with a curved façade.

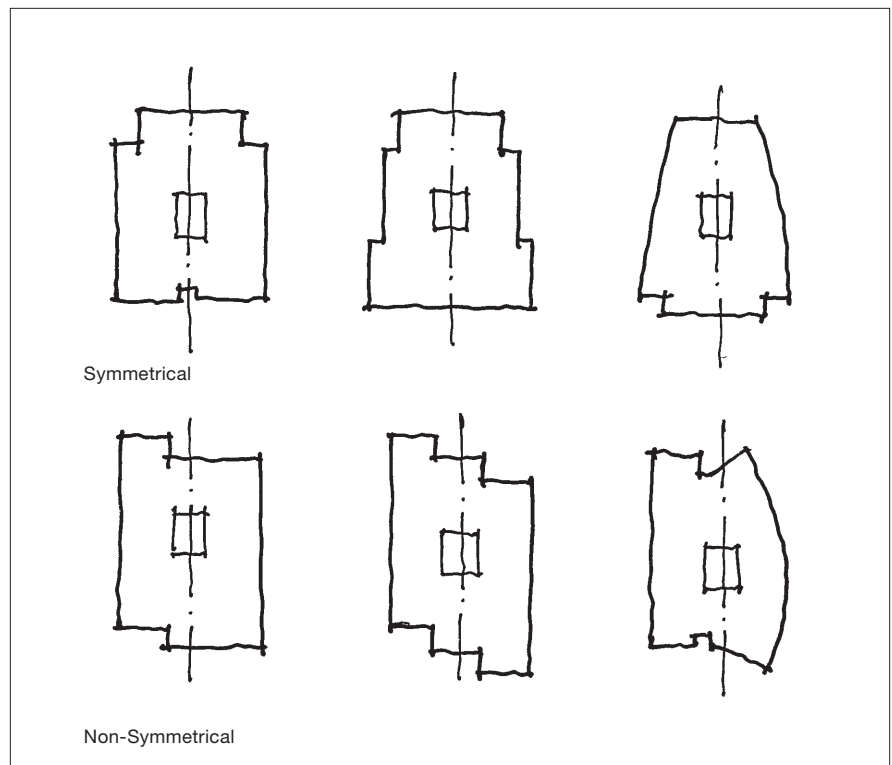

Floor plate segmentation – various examples.



Precedent – Tower base in proportion to tower shaft.



Precedent – Distinctive forms and materials are encouraged.



Precedent – Boot character consistent with adjoining tower.

**Guidelines**

**Tower Base** – Tower base (podium) and tower shaft should be in proportion. Shorter towers will look more elegant if they reach the street and if the podium they are set upon is short; taller towers may look more stable if set on a taller podium, although consideration should also be given to letting them reach the street level, particularly where they are intended by the urban design to be landmarks.

**Innovation** – Innovative materials and forms that creates distinctive buildings is particularly encouraged for towers, since they are intended to be landmarks.

**Boot** – Boots (low-rise or mid-rise extensions of towers) should have a character that is consistent with the tower in order to unify the two forms. Tower should be positioned at the end of the boot, so that the tower meets the ground. The tower should not sit on top of the boot.

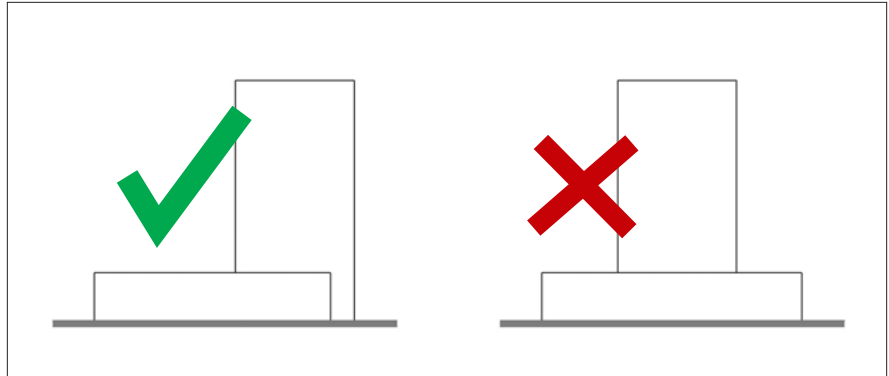

Boot – Tower should sit at end of boot, not on top.



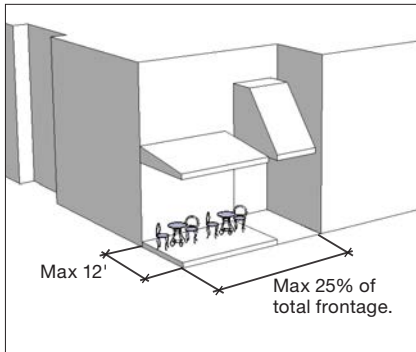

Build-to Line exemptions.



Canopies and building recesses create inviting spaces.

## B – Commercial : General

### Intent

The following standards and guidelines apply to all commercial buildings. Standards and guidelines specific to the commercial building type are set forth on the following pages.

### Standards

**Setbacks** – There are no required setbacks for commercial buildings.

**Build-to Line** – 85% of the building face shall be built to the property line. Patio spaces, entrances, publicly accessible plazas and walk-up windows are exempted provided they are stepped back no further than 12 ft from the property line and cumulatively for no more than 50% of the building face. Refer to Section 5.3.6 for exceptions to build-to-line percentages for commercial office and retail buildings within Candlestick Center.

**Projections** – Projections are permitted for awnings, canopies, signage and lighting to a maximum of 5 ft into the public right-of-way provided they have a minimum of 9 ft clearance to the sidewalk.

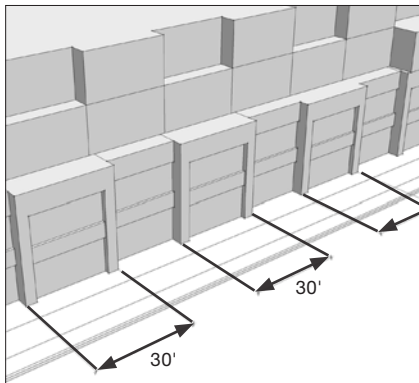

Storefront bays articulated at regular increments.



Precedent – Storefront glazing.



Precedent – Retail entrances should be clearly distinguishable from residential entrances.



Precedent – Integrated canopy and distinct bays.

## B – Commercial : Retail and Mixed-use

Note: See residential standards for residential levels above retail. Standards for Retail building types in Candlestick Center are found in Section 5.3.

### Intent

Retail should engage and enliven the street. Emphasis should be placed on using glazing and creating an architectural rhythm at the ground plane.

At-grade Activation standards for Harney Way and Ingerson Avenue are covered in Section 5.3.8.

### Standards

**Sidewalk Relationship** – Retail buildings shall be oriented to and meet the sidewalk at grade.

**Storefronts** Shall promote pedestrian interest at the ground level and provide visual connection to the store interior with:

- Store frontage shall have at least 60% glazing; glazing shall be transparent. Large multi-story retailer's upper floor levels shall also meet this glazing requirement.
- Outdoor displays and patios are encouraged, but shall maintain a minimum 6 ft wide clear pedestrian zone within the public sidewalk.
- Interior displays shall provide visual permeability into store interior.

**Store Height and Depth** – All retail spaces along both sides of Harney Way and Ingerson Avenue at Candlestick Center shall be a minimum of 20 ft height and have a minimum average depth of at least 35 ft, exclusive of service corridors. Minimum depth shall not apply to storefront liners of large format retail uses. All other retail uses shall have a minimum height of 15 ft.

**Façade Articulation** – Retail bays shall be no wider than 30 ft in order to create a fine-grained pattern of shops. Where a larger retailer is anticipated, bays can be combined; however the bay articulation shall be maintained. The impact of large retail stores can be mitigated by 'Wrapping' exterior façades with smaller retail stores, thereby breaking up the façade and reducing large expanses of blank walls.

### Guidelines

**Entrances** – Retail entrances should be easily identifiable and distinguishable from residential entrances. They should be reinforced with such elements as recessed doorways, awnings, special lighting, fenestration, color and materials, and special paving. Multiple entrances to larger stores are encouraged.

**Materials** – Façades should be designed with high-quality materials that offer color, variety, and visual interest to the pedestrian (such as stone, tile masonry, brick or terra-cotta).

**Canopies/Awnings** – Canopies or awnings should be provided for the sun, wind and rain protection of pedestrians. Their design should be integrated with the building architecture. Permanent materials are encouraged over vinyl or fabric.



Precedent – Office entrance integrated into retail frontage.



Precedent – Office above retail.

## B – Commercial : Office

Note: Standards for Office building types in Candlestick Center are in Section 5.3.

### Intent

Offices may be provided as a single use or may be located above some retail uses. Where permissible, office design should be compatible with ground level uses while providing clear architectural distinction.

Additional small office spaces may be located throughout the site, but will be designed in accordance with ground level retail space.

### Standards

**Streetwall** – All streetwall edges shall conform to general commercial standards. See B – Commercial:General and Figure 4.8, Figure 4.5 and Figure 4.7.

### Guidelines

**Entrance** – Entrances to office uses should be clearly defined by an architecture vernacular consistent with the building above, tying the office space use to the ground plane. Lobby size and character should relate to the size and character of the office space above. Lobbies should be inviting spaces; public art is strongly encouraged.

**Sustainable Features** – Solar shading, green walls, and other design elements are encouraged to be incorporated into the building façade of office buildings.





Precedent – Engaging lobby.



Precedent – Frames and activates public plaza.

## B – Commercial : Signature Building

### Intent

A signature building is planned at Candlestick Center on the corner of Harney Way and Ingerson Avenue. The building will frame a public plaza at the intersection and have high-quality architectural treatment that reinforces its central location and community importance. The Building should have Active Uses that encourage day and evening use, such as retail and entertainment.

### Standards

**Required Ground Floor Commercial** – Retail and ancillary uses that support the activities within the building shall be incorporated into the building façade to flank each side of the lobby.

**Required Entrance Plaza** – A public plaza shall be located in front of the building lobby and shall have a minimum area of 875 square feet. It shall be designed to incorporate public art and be adequately sized to serve as a gathering space and focal point. The plaza design should compliment and integrate with the architecture of the Signature building.

**Streetwall** – All streetwall edges shall conform to general commercial standards with the exception of setbacks and Build-to Line, for which the building has no prescribed standards. If the building is set back from the property line, this zone shall be used for a plaza and landscaping in a manner that complements the buildings use and architectural character. See B – Commercial : General.

### Guidelines

**Lobby/Foyer** – The primary entrance to the building should read as an extension to the public realm. Pedestrians should feel welcome to enjoy the building’s unique architecture.

**Iconic Architecture** – As an iconic landmark, the building’s architecture should highlight its importance through bold design, including form, materials, and color.

**Plaza Climate Considerations** – The location and design of the entrance plaza should incorporate solar and wind impact considerations.

**Loading** – The location of off-street loading requirements should take into consideration the need to minimize interference with pedestrian activity.



Precedent – Active frontage.



Precedent – Clearly defined entrance.

## B – Commercial : Hotel

### Intent

One hotel is planned within the Candlestick Center neighborhood. The hotel should be well designed and incorporated into the overall urban fabric, encouraging guests to participate in the life of the neighborhood.

### Standards

**Streetwall** – All streetwall edges shall conform to general commercial standards. See B – Commercial : General, Figure 4.8 and Figure 4.5.

**Active Frontage** – Hotels shall have active and engaging uses at-grade, including check-in desk, concierge, valet, cafés, restaurants, or other retail uses, creating a strong connection between the public realm and building's interior.

**Pedestrian Entrance** – The hotel entrance shall be clearly defined with adequate signage and architecture treatments to ensure easy identification for guests and visitors alike. The entrance shall be located on a public street so that it plays an active role in strengthening the commercial fabric of the street.

**Parking and Loading Entries** – Shall be treated so their appearance is minimal and not a predominant feature of the hotel, and port-cochères shall be designed to enhance the surrounding urban environment or treated so that their appearance is minimal. Where it doesn't undermine general site circulation and access, parking and loading entries shall be combined or coordinated with curb cuts and entry points to other garages within Candlestick Center.

### Guidelines

**Blank Walls** – Where a substantial length of windowless wall is found to be unavoidable, some combination of eye-level displays, contrast in wall treatment, offset wall line, outdoor seating, and/or engaging landscaping should be employed.



Precedent – Community center on Market Street.



Precedent – Fire station in San Francisco as part of the street fabric.



Precedent – Recreational facilities.

## C – Other : Community Use

### Intent

There are several development parcels allocated for community uses. The specific uses of these parcels will be determined in the future through community consultation, but may include: fire facilities, police facilities, daycare, senior’s housing, recreational and meeting space, performance spaces, sub-stations and other uses deemed to benefit the community.

The purpose of the following standards and guidelines is to facilitate the design of the buildings that will be consistent with the architectural character, in particular commercial buildings.

### Standards

**Active Frontage** – The building shall be sited at the street frontage in order actively engage the public and contribute to the fabric of the streetscape, unless it is within a park system where it shall be sited to be highly accessible to the majority of park users.

**Community Developed Program** – Program shall be determined through consultation with the community.

**Sub-station Screening** – Sub-stations shall be screened from view of public spaces (streets, parks) by a minimum of 8 ft high hedgerow or full screen fence.

**Streetwall** – All streetwall edges shall conform to general commercial standards. See B – Commercial : General and Figure 4.8 and Figure 4.5.

### Guidelines

**Transparency** – Should provide a minimum 50% transparency within the vertical plane on the street-facing side(s), unless specific programming requirements preclude this.

**Contextual Design** – Where building is an integral part of the street wall, it should complement the scale, massing and general proportions of surrounding buildings.

**Iconic Architecture** – Where building stands alone, it should be an expressive design that has a simple roof form and unique elements that distinguish it as a civic building.





Precedent – Cafe/restaurant building.



Precedent – Restroom building.



Precedent – Amphitheater structure.

## C – Other : Park Buildings

### Intent

New park buildings will be located throughout the development to enhance the park experience for users. Small auxiliary buildings may include rest rooms and covered picnicking areas, while other larger buildings may be included, such as a gymnasium, gazebo, covered performance space, restaurant, and park staff office space.

### Standards

#### Location and Design

- The maximum height of park buildings shall be 40 ft.
- Park buildings shall not have blank walls greater than 16 ft.
- Buildings shall be sited in areas of high activity within the park system, including as extensions of development streetwalls along major streets.
- Layout, fenestration and entrances shall encourage public use.
- Adequate signage shall be placed within the park system and streetscape to facilitate wayfinding.

### Guidelines

#### Expressive Design and Character

- The building should have an expressive design that includes a simple roof form and unique elements that distinguish it as a publicly accessible building.
- New buildings within the park system should have a high degree of transparency and an architectural style and composition consistent with the surrounding neighborhood.

**State Park** – Buildings within the State Park are not subject to the standards and guidelines listed above; however, consultation with the City and public for any construction on State Park lands is recommended.

## D – Parking Facilities

### Intent

Parking facilities, whether stand alone or part of a multi-use block or building, should be screened so that they do not negatively impact the streetscape or other public spaces. Façades should be wrapped by Active Uses or visual screens and roofs should be screened with landscaping or Active Uses. The standards described herein are for both parking facilities that are fully or partially integrated into residential or commercial buildings. Additional details related to parking facilities are included in Section 4.2.4 and Section 4.5.

### Standards

**Wrapping Uses in Multi-Use Buildings** – All multi-use buildings or blocks shall have Active Uses that wrap the street frontage so that parking is concealed internally. See Section 5.3.7 for standards requiring screening for parking facilities in commercial and mixed-use buildings in Candlestick Center.

**Wrapping Uses in Single-Use Parking Structures** – With the exception of any parking facility frontage along Arelious Walker Drive, the street level building face of all single-use parking structures shall have Active Uses.

**General Screening** – All façades of parking facilities shall have screening where there is no Wrapping above the ground floor, as well as where At-grade Activation is not required or otherwise provided, at the ground floor. Screening shall utilize entrances and bays in a rhythm and scale compatible with architecture of surrounding buildings. In addition, at a minimum, screening shall be sufficient to ensure that the headlights of vehicles and direct glare from unshielded light fixtures shall not result in light trespass onto adjacent or nearby land uses.

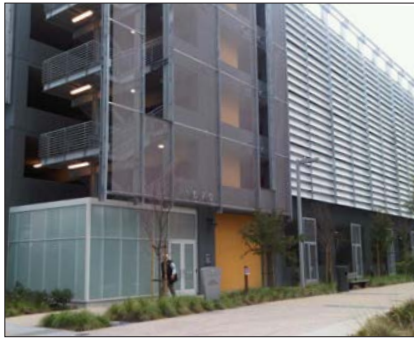

Precedent – Parking structure screening where Active Uses not feasible.



Precedent – Screened structure with photovoltaics on the roof-deck.



Precedent – Screening with graphic panels.



Precedent – Screening with Active Uses at street level and green wall.

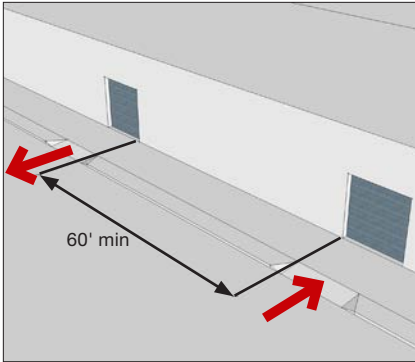

Garage ingress/egress separation.

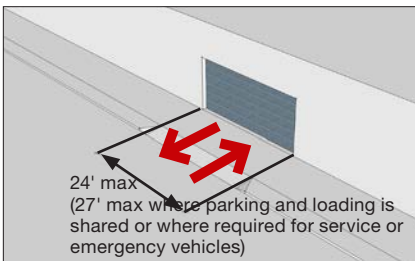

Combined ingress/egress maximum width.

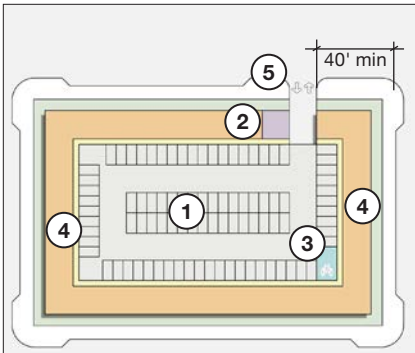

Screened parking garage showing Active Use area.

- ① Parking Garage
- ② Loading
- ③ Bicycle Storage
- ④ Activated Uses with Access Corridor
- ⑤ Entrance

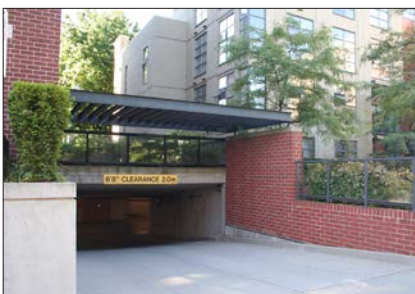

Precedent – Residential parking entrance concealed by canopy and landscape.

**Entrance** – Unless otherwise provided for in this D4D, the combined parking ingress and egress entrance for structure off-street parking shall be a maximum width of 24 ft. This may be increased to a maximum of 27 ft where:

- access to off-street parking and loading is shared; or
- the extra width is needed to accommodate the fleet of emergency services or utility providers.

Separate parking ingress/egress shall be a maximum width of 11 ft and be spaced a minimum of 60 ft apart to re-establish the building façade. The sharing of parking entrances and loading is encouraged. The number of entrances is limited to a single ingress and egress unless a traffic impact analysis (TIA) substantiates the need for a second ingress/egress based on either volume or travel distance requirements. Shared parking entrances shall be a minimum of 40 ft from block corners and 20 ft from building entrances. The maximum width for a freestanding townhome entrance shall be 8 ft.

**Landscaping** – Underground parking structures that extend beyond the building face shall provide a minimum 36 in soil depth above where landscaping is provided.

**Roof Deck** – Parking stalls on any roof deck shall be 50% shaded through the use of landscaping (5 years from construction), photovoltaic trellises or any other appropriate high albedo shading techniques.

**Materials, Finishes & Colors** – All elements of the parking structure that will be visible from the public realm shall use textured and/or non-reflective materials, finishes and colors.

**Lighting** – Any lighting shall be concealed, focused on the intended area of illumination and directed away from surrounding land uses.

**Guidelines**

**Entrance Concealment** – Parking entrances should be situated away from direct sightlines and in areas that are away from high pedestrian or vehicular traffic areas, and concealed by the use of canopies, landscaping and setbacks.



### 4.3.2 General Building Elements

For all building types, there are various common characteristics that create a strong sense of place within the plan. These are:

- A Base Activation
- B Façade Articulation
- C Materials and Colors
- D Corners
- E Roofs
- F Private Open Space
- G Sustainable Features
- H Building Lighting

Note: For office buildings, retail buildings, and parking facilities in the Candlestick Center, see additional Building Element standards in Section 5.3.



Precedent – Base Activation.



Precedent – Façade articulation.



Precedent – Distinctive corner.



Precedent – Coordinated color palette.



Precedent – Distinctive roof.



Precedent – Sustainable elements.



Precedent – Lighting at entrance.



Precedent – Signage integrated into form.

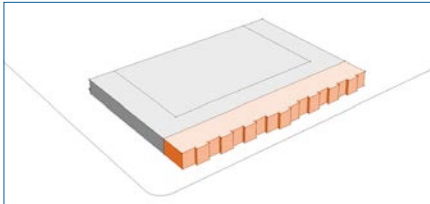

Retail/entertainment/office added to edge of podium on mixed-use streets.

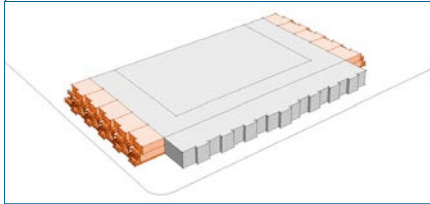

Residential townhomes and lobbies lining podium on residential streets.



Precedent – Townhomes lining podium.



Precedent – Retail lining podium.



Precedent – Entrance clearly defined.



Precedent – Individual entrances facing street.

## A – Base Activation

### Intent

The base of buildings should animate the street by containing active uses supported by generous windows, entrances and outdoor spaces at the street level. Active Uses can include street-level residential units with streetfacing entrances, retail and restaurants that meet and engage the sidewalk with ample glazing, displays and inviting entrances, entertainment, commercial offices (subject to entitlement limitations) and lobbies.

### Standards

**At-grade Activation** – Along public streets and mid-block breaks, uses at-grade shall be Active Uses. These include residential, retail, office (subject to entitlement limitations), lobbies and other uses defined in the Appendix. Activation standards for Candlestick Center (including for segments of Ingerson Avenue and Harney Way) are found in Section 5.3.

**Blank Wall** – A blank wall is defined as having no Active Uses including no glazing or doorways, excluding parking garage entrances. A building facing a street, mid-block break, or open space shall have no single blank walls more than 16 ft in length for residential buildings and 8 ft for commercial buildings. The total amount of blank wall shall be limited to 20% or a total of 40 ft of building face, whichever is greater. Display windows are not considered blank walls, provided they allow visual access into store interior.

**Main Building Entrance** – The main building entrance shall be prominent and expressed by such elements as taller volumes, recessed doorways, canopies, lighting, public art, water features, special materials and paving. Entrances shall be easily identifiable and well lit for convenience, visual interest and increased safety.

- ① Bays and materials distinguish townhome base.
- ② Raised patio and stoop create secondary entrances and promote 'eyes on the street'.
- ③ Plantings enhance privacy and create a greener street.

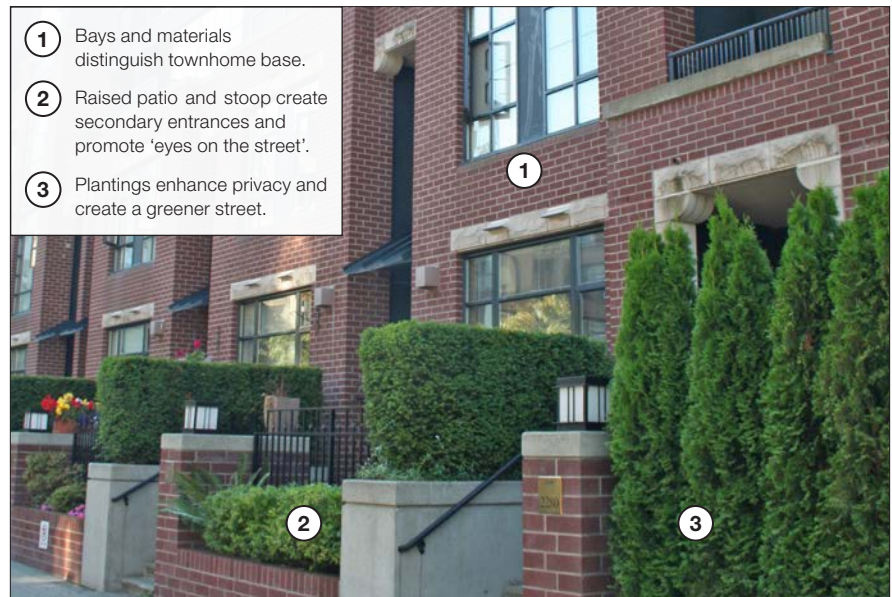

Precedent – Activation of street with residential.





Precedent – Garage entrance off private driveway.



Precedent – Artful elements incorporated into façade.

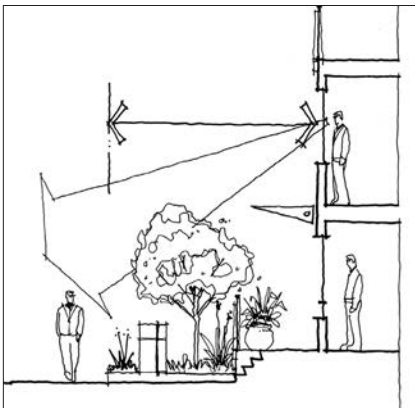

Eyes-on-the street design principles encourages safety.

**Individual Entrances** – All ground floor units facing a public right of way or pedestrian mews shall have street-facing entrance area (patio/stoop) that serves as a transitional area between the building and public realm. Design shall emphasize safety, security, and render the entrance easily identifiable and visually appealing. Entrances shall define private space by creating a sense of ‘territoriality’ while remaining visually accessible from the street.

**Garage Entrances** – Entrances to individual residential garages shall be limited to one per unit to a maximum 8 ft width. Entrances may be located on private lanes including in mid-block breaks. They are not permitted on public streets except for Candlestick South blocks 3 and 5 (for standards on common parking structure entrances, see 4.5.1).

**Guidelines**

**Neighborhood Retail** – Neighborhood serving retail is encouraged in the base of residential buildings at higher pedestrian traffic areas.

**Decorative Elements** – Decorative elements that evoke the community character are encouraged. These include use of color, banners and signage.

**Artful buildings** – Buildings themselves are encouraged to be artfully designed. This may include dynamic building elements or public art that is incorporated into building façades or entrances and lobbies.

**Safety** – Buildings and public space should be made safe by ensuring natural surveillance and clear legible boundaries and pathways. ‘Eyes on the street’ principles should be employed by locating doors, windows, and open spaces to face public streets and parks.



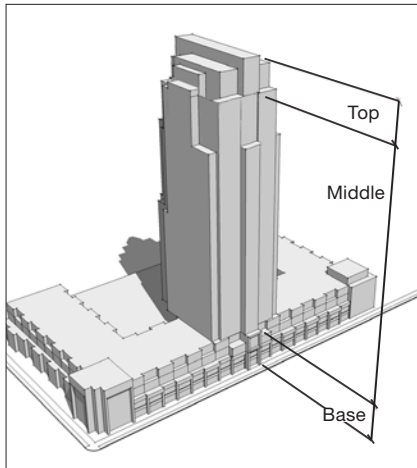

Vertical articulation of high-rise – Base, middle, top.

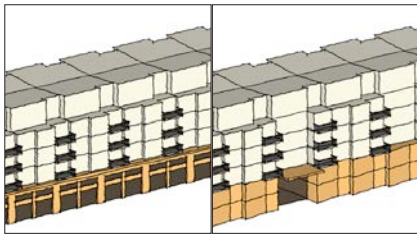

Base section – Retail and residential conditions.

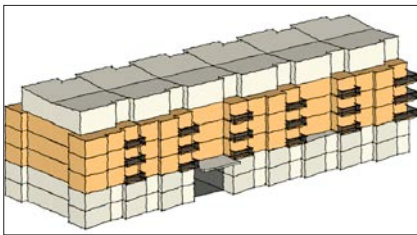

Middle section.

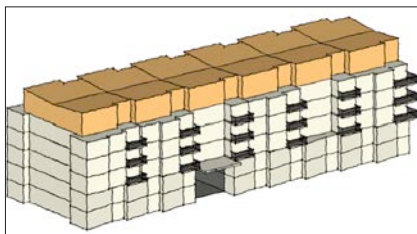

Top section.

## B – Façade Articulation

### Intent

The façade of buildings should be purposefully articulated (i.e. defined, made clear) in order to make legible the various building functions (i.e. lobby, residential and retail) and segments (i.e. base, middle, top), and reduce its apparent mass.

The building façade should also help create a strong sense of identity for the building and be designed at one holistic scale where the massing, building details, and entries are proportionally related.

### Standards

**Vertical Articulation** – The three segments of the building, base, middle and top, shall be articulated by such elements as cornices, string courses, stepbacks, recesses and projections, changes in floor height, and changes in color and material.

- **Base Section – Retail/Residential**
  - Shall relate directly with the street and add to the vitality of the public realm.
  - Shall ‘ground’ the building;
  - Retail shall have maximal glazing, and characterful signage and awnings (see Section 4.3.1 B).
  - Residential shall be defined through active elements such as doors, patios and stoops, and/or material and/or color differences.
- **Mid Section**
  - Shall define the principle building façade.
  - Shall differentiate from base- and top-sections through the use of materials and/or color.
- **Top Section**
  - Shall define roof line.
  - Penthouse units shall be stepped back from primary building face (see Section 4.2).



Precedent – Horizontal articulation by massing, materials and details.



Precedent – Horizontal articulation by rhythm of bays.



Precedent – Townhome base.

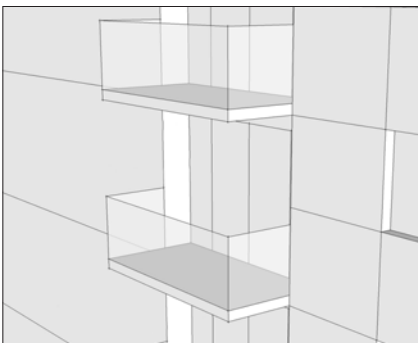

Balconies as integral part of façade articulation.

**Horizontal Articulation** – The first 20 ft height of the building faces shall have a rhythm of modules that serves to break down the scale of the building face. The maximum dimension of any module shall be 30 ft. A module shall be defined as a portion of the façade that is differentiated from the adjacent façade by a change in the line of the face of building, and/or a substantial change in material color or fenestration. Characteristics between modules should relate to one another to achieve a unified composition.

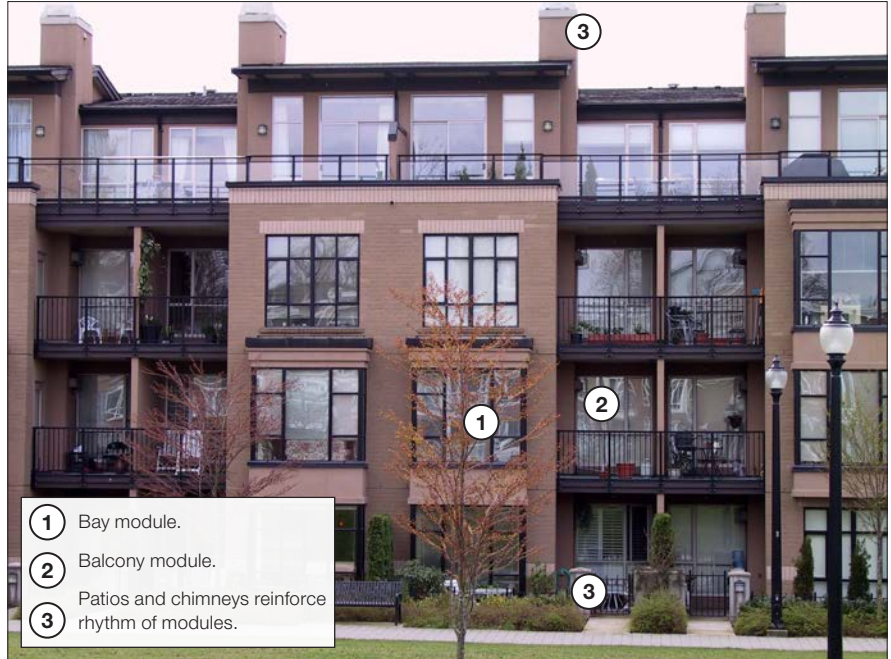

Horizontal articulation by differentiated modules.

**Guidelines**

**Fenestration** – Windows should be proportioned relative to the scale of use. They should be elegant in form and complement the palate of other elements.

**Balconies** – Balconies should be designed as an integral component of the building form in order to not appear ‘tacked on’. Full depth balconies are encouraged. Shallow depth ‘Juliet’ balconies are allowed, but balconies with a depth of under 6 ft may not be counted as open space.

**Sustainable Features** – Green (planted) walls, photovoltaics, and other sustainable features that reduce the overall energy consumption of a building are encouraged. Buildings façades should be designed to take advantage of passive solar design principles and maximize natural ventilation and interior day lighting.

**Innovation** – Innovation in building form, sustainability, and energy use is encouraged providing it meets the overall intent of the building design guidelines.

**Lighting** – Lights should be subtle and reinforce the overall façade design.



Precedent – Durable materials.



Precedent – Coordinated materials and colors.



Precedent – Consistent palette of materials creates clear building identity.



Precedent – Materials and their proportionate use reinforce the building form.

## C – Materials and Colors

### Intent

Building materials and colors should be carefully selected to achieve an overall built form that accentuates the uniqueness of individual buildings, and adds to the fabric of the street. Materials should be high quality and durable, and should suit the local environment. Materials on any one building should be carefully chosen to form a pleasing and controlled composition of the elevations and building mass.

### Standards

**Walls** – Permitted materials include: high quality finish cast in place or precast concrete, unitized ceramic panels, high quality non-reflective metal panels, brick, stone, wood, stucco, cement fibre lap, curtain wall glazing systems and photovoltaics forming an exterior wall system.

**Glass Types** – All glass inclusive of the glazing system, shall perform to the minimum or better of the State Energy Standards. Innovation related to sustainability is encouraged in the choice of glass and glazing products. Not permitted: reflective glass; greater than 10% tinted glass.

**Durable Materials** – Materials shall be durable and of high quality and respond to the site's maritime climate by utilizing appropriate envelope systems.

### Guidelines

**Smart Buildings** – The use of intelligent building skins, such as self-cleaning façades and glass, is encouraged.

**Local and Sustainable Materials** – To the extent possible, locally sourced materials should be used to help establish a palette that works with climate, light, history, and culture. Sustainable and recycled materials are highly encouraged.

**Building Form** – Materials and colors should highlight and reinforce unique forms within a building, such as base and corner elements, entrances, and other features.

**Colors** – Building should be composed of a well controlled and balanced palette of colors and textures. The color and material palette should contribute in a thoughtful manner to the overall fabric of the neighborhood.





Precedent – Reinforce buildings’ corners at important intersections.



Precedent – Commercial at corner.



Precedent – High-rise bustle at corner.



Precedent – Unique element reinforcing corner.

## D – Corners

### Intent

Key intersections within the plan serve as gateways into the overall development or neighborhoods; these locations are identified in Section 5, Neighborhood Standards and Guidelines. Building corner design at these locations will help create a unique emphasis on such gateways and establish an overall character for the neighborhood. Buildings at all other street corners should also be carefully designed to reinforce the importance and visibility of these locations.

Corners are important elements of the public realm; therefore, mechanical, service, exposed parking and loading are prohibited at block corners.

### Guidelines

**Corner Expression** – Buildings at intersection locations should have special architectural treatments that reinforce the street corner’s importance as a public realm element. This may be achieved through a change in massing, a contrasting façade finish and/or transparency.

**Materials** – Building materials should turn the corner. Where materials change from one façade to the next, such a change should be thoughtfully developed as an integral part of the design theme for the building.

## E – Roofs

### Intent

Building roofs will be visible in many cases from surrounding buildings or neighborhoods. Accordingly, roofs should be an integral aspect of the building and an expressive opportunity that should be attractive and usable for outdoor use, energy production, or stormwater storage.

### Standards

**Mechanical Equipment** – Rooftop mechanical equipment including elevator / stair cores more than 6 ft above the roof line shall be screened from view of neighboring units. The mechanical screens shall form part of the building top composition and consist of materials consistent with the overall building color and material palette.

**Solar Energy** – Buildings shall provide ‘solar ready’ infrastructure such as solar panel curb standoffs, conduits, and roof water spigots that minimize the cost and effort of adding solar capacity at a later date. As an alternative, infrastructure shall be provided for solar hot water panels, minimizing future disruption to the building envelope and roof membranes.

**Stormwater** – Roofs shall be designed to accommodate water quality objectives. See Section 4.3.2 G and separate ‘Infrastructure Plan’ and ‘Sustainability Plan’ for more details.

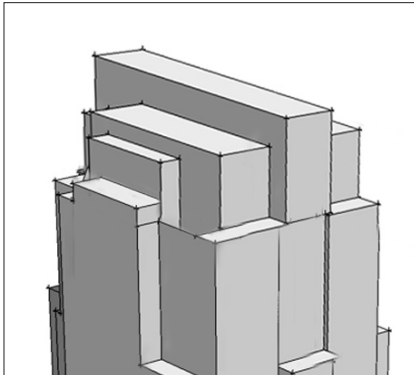

Articulated roof.

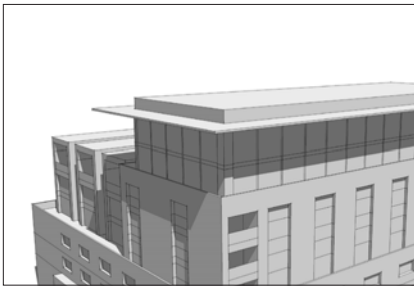

Sheltering roof.

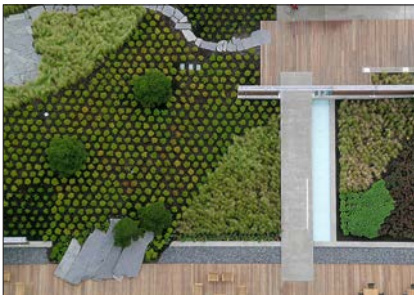

Precedent – Green roof.



Precedent – Solar panels.

## Guidelines

**Fifth Façade** – Where roofs are viewed from above they should be considered as a ‘fifth façade’ and designed to provide an attractive view from above after meeting the requirements of rooftop mechanical and solar equipment needs.

**Articulation** – The roof line should be articulated to reinforce its role as the top of the building and should form an integral part of the overall building composition. Expressive and sculptural roof forms that will be seen from a distance are encouraged. Wherever possible, roof mechanical exhaust vent and equipment projections should be clustered and set back from the edge of buildings that are visible from the street or points above.

**Color** – The use of high albedo and landscaped roof is encouraged to prevent heat island effect.

**Usable Roof Terraces** – Usable terraces on building roofs and podiums are encouraged where possible. Trellises and open structures should be designed as part of the overall roof composition.

**Green Roof** – Green roofs are encouraged and should be insulated to minimize heat and noise transfer and use regionally appropriate plant species to minimize water consumption requirements. Drip or bubbler systems to establish green roof plants are permitted, but once the planting has been established the temporary irrigation systems should be disconnected and rendered unusable.



Townhome entrances and elevated patios with privacy screening.



Precedent – Patio extends livable space.

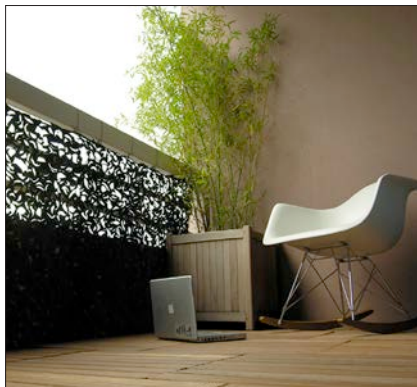

Precedent – Private balcony.



Precedent – Common open space.

## F – Private Open Space

### Intent

Buildings have three distinct open spaces:

- Private at-grade patios and stoops within the building setback zone.
- Private above grade balconies and rooftop decks.
- Common (shared) open spaces.

**Private at-grade patios and stoops** create spaces for individual expression and opportunities for casual neighborly encounters. They should contribute to a safe and engaging public realm by having direct access from the street.

**Private above-grade outdoor open spaces** should be designed to a high standard and be carefully programmed and located to ensure usability. Private open spaces include terraces, patios, balconies, and possibly rooftop space, and are intended for the use of individual residents within a unit.

**Common open spaces** are intended for the use of all residents within a building or building cluster, and include rooftop spaces and internal courtyards.

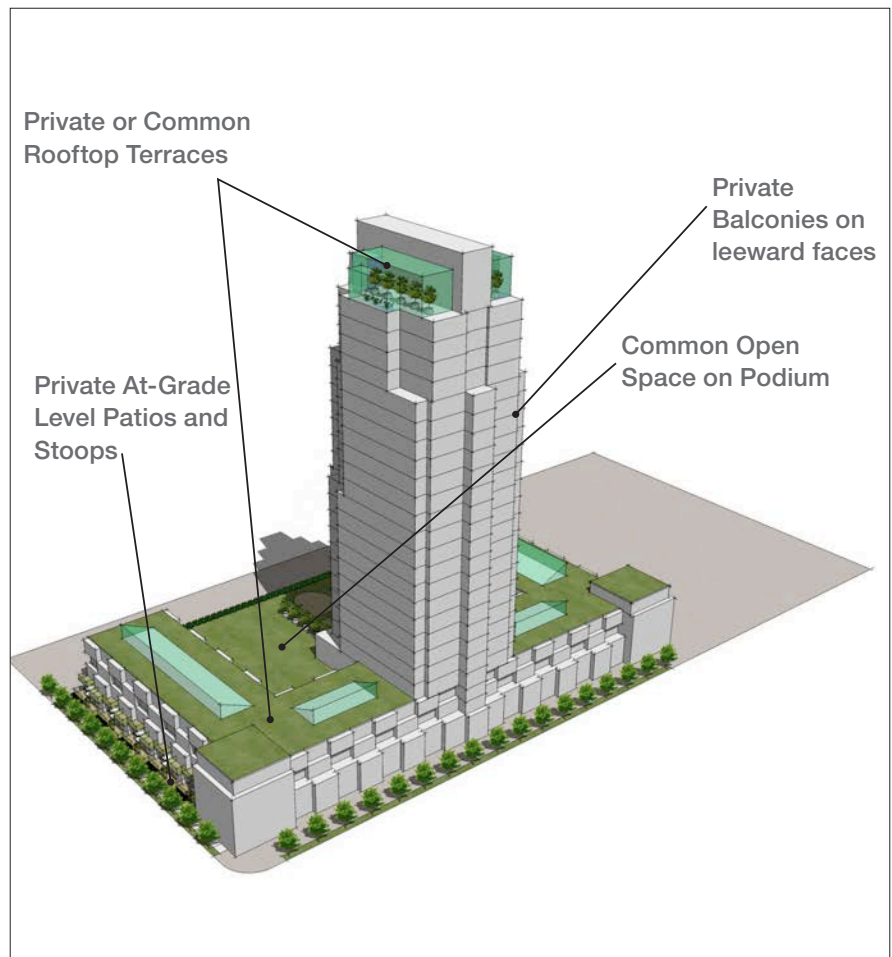

Private open space zones.



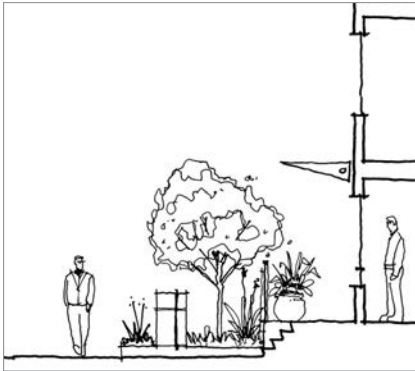

Elevated and screened patio.



Precedent – Landscaping for privacy of patios.



Precedent – Maximize solar access.



Precedent – Common outdoor space with variety of program elements.

### Standards

**Total Open Space Area** – Every building shall have a minimum net usable open space equivalent to 60 sq ft per unit. Areas underneath a projection that has less than 9 ft clearance shall not be included. At the developers’ option, open space shall be permitted as either Private Open Space or Private Common Open Space or any combination of both.

See Section 5.3.9 for additional private open space provisions for buildings within Candlestick Center.

**Private Open Space** – Individual private open spaces shall be a minimum of 36 sq ft. Areas underneath a projection that has less than 9 ft clearance shall not be included. Open space with a dimension of less than 6 lineal ft in any direction shall not be counted towards total.

**Private Common Open Space** – Shall be a minimum of 100 sq ft open space. Areas underneath a projection that has less than 9 ft clearance and areas with a dimension of less than 10 lineal ft in any direction shall not be counted towards total.

**At-grade Open Space** – The setback zone of all residential buildings shall be used either to create high quality, usable open space for street-facing units, or in the case of building entrances to create a transition zone between private use and the public realm. Permitted uses within the setback zone include street-facing stairs, stoops, porches, patios, landscaping, driveways and entry plazas. The setback zone shall be landscaped with high quality materials from the building edge to the public sidewalk.

**Grade Separation** – Ground floor units shall be elevated above the street by between 2 ft and 4 ft.

**Fences and Gates** – Fences and gates shall be a maximum height of 4 ft as measured from their base.

**Lighting** – All lighting fixtures shall be low intensity or low-level of intensity and unobtrusive.

**Stormwater Treatment** – Standards are contained in Section 4.3.2 G.



Precedent – Patio in setback zone.





Precedent – Wall, fence and planting combine to enclose patio space.



Precedent – Common space with seating areas.



Precedent – Private gardens on podium.



Precedent – Flowing water to mitigate surrounding noise.

### Guidelines

**At-grade design** – stoops and patios at grade should be designed in order to achieve usable space for residents, while also providing safety measures to ensure the space is defensible. Defensible design includes gates and railings, and appropriate landscaping to provide buffer from street while also allowing visual connections between the street and residence.

**Orientation** – Orientation of all open spaces should maximize solar access and views. Balconies on high-rise towers are encouraged to be located away from building corners that face the prevailing wind direction.

**Safety** – Common spaces should be inviting, interesting, and safe.

**Rooftop / Podium Deck Design** – Deck design should provide visual interest from surrounding overview homes.

**Common Space Programming** – A variety of programming uses should be provided to appeal to various constituents. This may include planters, paved areas, pools and play areas.

**Plant Palette** – Native and climate appropriate plants are encouraged.

**Irrigation** – Water demand should be minimized by carefully controlling irrigation timing and application.



Precedent – Common open space on podium.



Precedent – Privacy separation.



Precedent – Stormwater capture and treatment.



Precedent – Passive energy system.

## G – Sustainable Features

### Intent

Sustainable development practices are highly encouraged in implementing the sustainability vision summarized in Section 2.3. A variety of standards and guidelines are described below to ensure that baseline practices are followed.

Buildings and their associated landscapes should utilize industry-leading sustainability features. Innovative sustainable approaches at all levels are strongly encouraged.

### Standards

**Stormwater Treatment** – Storm runoff from development parcels shall be treated before draining to the stormwater system; this shall be accomplished using low impact development treatment measures as prescribed in the ‘San Francisco Stormwater Design Guidelines’. For volume based treatment methods, the LEED sustainable sites Credit 6.2 shall be followed.

**Green Building Ordinance** – All new buildings shall be subject to the City and County of San Francisco Green Building Ordinance.

**Reclaimed Water** – Reclaimed water infrastructure (purple pipe) shall be installed as part of land development.

**Climate Appropriate Vegetation** – All buildings shall use climate appropriate vegetation that does not require permanent irrigation for landscaping open spaces, rooftops and green walls.

**Title 24 (2008) Energy Standards** – All new buildings shall be designed to exceed Title 24 (2008) energy standards by at least 14%.

**Landfill Diversion** – Construction of new buildings and demolition of existing buildings shall require that at least 75% of generated debris and waste be diverted from landfill with a goal of 90%.

**Recycling** – Dedicated recycling facilities are required for all buildings.

**Concrete** – Concrete used in building construction shall include at least 25% fly ash or slag.

**Solar Ready** – All new buildings shall be required to provide ‘solar ready’ infrastructure such as solar panel standoffs, conduit or roof water spigots that minimize the cost and effort of adding solar capacity at a later date.





Precedent – Wind turbine.



Precedent – Solar screens.

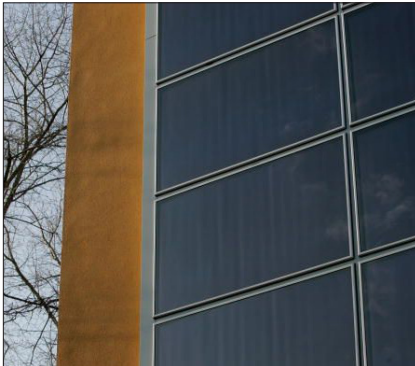

Precedent – Solar panels.

### Guidelines

- Sustainable elements should contribute to the cohesive whole of the building and site design.
- Encourage building form, orientation and thermal mass that optimize solar radiation, natural ventilation and day lighting.
- Reduce heat-islands by providing light colored / high albedo materials, pervious landscape, high emissivity roofing and green roofs.
- Eliminate light trespass from the building and site, improve night sky access and reduce development impact on nocturnal environments.
- Use regionally manufactured building materials.
- Use durable, thermally efficient roofs, walls and windows that reduce heating and cooling and enhance thermal comfort.
- Use landscaping that requires little or no irrigation or application of synthetic chemicals.
- Rainwater is encouraged to be harvested for on-site uses such as irrigation.
- Use efficient HVAC and electrical lighting systems.
- Use water efficient supply and waste fixtures.
- Reduce the use of finite raw materials and long-cycle renewable materials by replacing them with rapidly renewable materials.
- Use building products that incorporate recycled content materials.
- Where possible, wood-based materials and products should be certified by the Forest Stewardship Council.
- Use adaptable interior designs, providing visual access to the outdoors and access to daylight.
- Use interior finishes and installation methods that have lower toxic emissions.
- Incorporate 'smart metering' building management systems and feedback panels into homes.
- Incorporate bird-friendly building design elements (e.g. non-reflective tinted glass).



Precedent – Lighting and building style integrated.



Precedent – Entry stairway lighting.

## H – Building Lighting

*Note: For information on street and park lighting, refer to the companion 'Parks, Open Space, and Habitat Concept Plan' and 'Streetscape Plan'.*

### Intent

Lighting on buildings shall be integrated into the architectural design to creatively illuminate pedestrian areas and highlight building elements without impacting surrounding land uses and the streetscape.

### Standards

**Fixtures** – All lighting fixtures shall be low intensity or low level of intensity and unobtrusive. Lighting shall be focused directly on the intended area of illumination and away from surrounding land uses. Full cutoff or fully shielded fixtures shall be used in order to avoid light being directed upwards or outwards. Zero candela intensity shall occur at an angle of 90° or greater above nadir. Additionally, no more than 10% candela intensity shall occur at an angle greater than 80° above nadir.

### Guidelines

**Pedestrian Areas** – Pedestrian areas should have adequate illumination for safety.

**Retail** – Lighting should integrate with retail signage, storefront windows and other building elements to enhance visual interest.

### Residential –

- Lighting should be sensitive to nearby residential developments by:
  - Limiting Glare.
  - Minimizing spill light beyond the property boundary.
- Within a development, common outdoor lighting should be designed to mitigate light trespass into adjacent units.

**Energy Consumption** – Sensor or timer-based shut off controls should be used for residential, pedestrian and parking areas.

## 4.4 Signage



Precedent – Signage should allow views in and out of the premises.



Precedent – Window displays should be visually interesting and use product display in lieu of signs and banners.



Precedent – Signs that contain visual representations rather than text are encouraged.



Precedent – The illumination source should be concealed

The following signage controls are intended to provide basic direction for how signage is displayed. More detailed signage provisions for public and street signage will be contained in the "Candlestick Point Signage Master Plan". Information on street and park signage may also be contained in the 'Parks, Open Space, and Habitat Concept Plan'.

### General

#### Intent

Signage should be artful, creative, add visual interest to the street, and complement overall building and site design. Signage utilized to identify a business or community use should be clearly identifiable, yet not be visually objectionable. Signage in the Mixed-use Residential and Open Space districts should be discreet, kept to a minimum and maintain a suitable level of amenity for residents and users of the public domain.

#### Guidelines

**Variety** – A variety of signage types serving a range of functions should be provided in a way that is responsive to the built form, site design, district character and streetscape appearance.

**Location** – Signs should not obscure architectural elements such as pilasters, cornice lines, capping or openings.

**Legibility** – Sign typefaces should be clearly legible.

**Materials** – Signs should be designed with high quality materials consistent with the overall building architecture.

**Style** – Signs that are visually representational rather than textual are encouraged. Signs should be artful, creative, and highly graphic.

**Orientation** – Signs should be positioned and oriented to be easily visible to pedestrians.

#### Lighted Signs

- The brightness of any illuminated sign should be limited to the minimum necessary for it to be operationally functional and compatible with the light level of the streetscape it is located in.
- Wherever possible, signs should be designed so that their brightness does not cause glare or detract from the amenity of nearby residential land uses.
- The light source, junction boxes, tubing, conduits and raceways should be concealed or incorporated into the design of the sign structure.

**Safety** – Sign design and operation must be safe for users of the public domain, including motorists, bicyclists and pedestrians.





Precedent – Use of new technology signs is appropriate provided there is no amenity or safety impact.

**New Technology Signs** – Signage using new forms of technology, such as dynamic content signs, digital displays or light projections, may be appropriate where designed, located, oriented and operated in a manner that avoids any negative amenity or safety impact on nearby residential land uses, motorists or bicyclists. This may include (but is not limited to):

- Limiting the hours of operation of the sign;
- Limiting the amount animation, or ensuring the content on dynamic content or digital signs has a minimum dwell time and transition time;
- Limiting sign brightness;
- Locating the sign inside a business premises and set back from window glazing; and
- Orienting the face of the sign away from the adjoining street network and land uses.



Precedent – Temporary contractor signs.

**Temporary Signage** – Temporary signage, such as contractor signs, real estate signs and special promotional signs, are appropriate where they are limited in size.

- **Contractors** – One sign for persons or businesses connected to work on buildings under actual construction or alteration. Signs shall not exceed 12 sq ft in size. Signs must be removed within seven days following completion of the contract.
- **For Sale / Lease** – One sign is allowed for each street frontage of the total parcel involved. The sign shall not be greater than 10 ft tall, and may not extend above the roof line if attached to the building. Sign area shall not exceed 6 sq ft for each lot or for each 3,000 sq ft in such total parcel, whichever permits the larger area; no sign shall exceed 18 sq ft. Signs must be removed within seven days following removal of the property from the market.
- Temporary signs should be displayed for a limited duration and removed immediately following the conclusion of the relevant activity. Where possible, temporary signage should be coordinated and integrated with other signage.
- Temporary signs should not be displayed or presented in a way that presents a public hazard, such as on the roof of a building or awning.



Precedent – Temporary for sale sign.

**Prohibited Signage** – The following sign types are prohibited:

- Permanent or temporary billboards (except as otherwise provided for in Section 4.3.10 of the BVHP Plan).
- Signage with reflective materials, colors and finishes.
- Signage with sound, vibration, odor or other emissions, unless the emission is necessary as part of a community message or to meet ADA standards.
- Signage that replicates, mimics or could be mistaken as a traffic control device.
- Signage that obstructs the passage or sightlines of motorists, bicyclists or pedestrians.
- Billposting, except where undertaken with the approval of the City or Agency.

## 4.5 Parking and Loading

### 4.5.1 Off-street Parking

#### Intent

Off-street parking in shared structures should be provided for all land uses in convenient locations that are visually concealed from view of the street by Active Users. Additional standards and guidelines are contained in Section 3.2, Section 4.2.4, Section 4.3.1D, and Section 5.

#### Standards

**Numbers/Ratio** – The maximum amount of off-street parking by use is described below. For residential parking, the maximum represents a cumulative total number of spaces equal to one space per unit. In the event some residential buildings provide for less than one space per unit, these unallocated spaces may be re-allocated to other residential buildings. But in no event shall the residential parking ratio exceed 1 : 1 at any given time. Re-allocation of any unused parking spaces shall be identified during the Design Review and Document Approval Procedure submission by sponsor. For additional detail, refer to the companion ‘Transportation Plan’.

Table 4.7 Maximum Off-Street Parking

USE	MAXIMUM
Residential	1 space/unit
Regional Retail	2.7 spaces/1000 sq ft
Office	1 space/1000 sq ft
Neighborhood Retail	1 space/1000 sq ft
Community Uses	1 space/2000 sq ft
Hotel	0.25 space/guest room
Performance Venue	1 space/15 seats
Cinema Parking	Where the number of cinema seats exceeds 50, one space for each eight seats up to 1,000 seats, plus one space for each 10 seats in excess of 1,000.
Grocery Store	2.7 spaces/1000 sq ft

**Bicycles** – Shall be located in a secured and convenient location that is near the garage entrance and does not conflict with autos. The standards for bicycle parking by use are listed in Table 4.9 and Table 4.10.

Table 4.8 Bicycle Parking Spaces for Residential Uses

	MINIMUM NUMBER OF BICYCLE PARKING SPACES REQUIRED
Dwelling units in all Districts	For projects up to 50 dwelling units: 1 Class 1 space for every 2 dwelling units.
	For projects over 50 dwelling units: 25 Class 1 spaces, plus 1 Class 1 space for every 4 additional dwelling units over 50.
Group Housing	1 Class 1 space for every 3 bedrooms
Dwelling units dedicated to senior citizens or physically disabled persons	None required

Table 4.9 Bicycle Parking Spaces for Commercial Uses

COMMERCIAL USE	MINIMUM NUMBER OF BICYCLE PARKING SPACES REQUIRED
New commercial buildings whose primary use consists of medical or other professional services, general business offices, financial services, business and trade schools, and development or manufacturing.	Where the gross square footage of the floor area exceeds 10,000 sq ft but is no greater than 20,000 ft, 3 bicycle spaces are required, of which at least 1 must be a Class 1 space.
	Where the gross square footage of the floor area exceeds 20,000 sq ft but is no greater than 50,000 feet, 6 bicycle spaces are required, of which at least 2 must be a Class 1 space.
	Where the gross square footage of the floor exceeds 50,000 sq ft, 12 bicycle spaces are required of at which at least 4 must be Class 1 spaces.
New commercial buildings whose primary use consists of retail, eating and drinking, or personal services.	Where the gross square footage of the floor area exceeds 25,000 sq ft but is no greater than 50,000 ft, 3 bicycle spaces are required, of which at least 1 must be a Class 1 space.
	Where the gross square footage of the floor area exceeds 50,000 sq ft but is no greater than 100,000 ft, 6 bicycle spaces are required, of which at least 2 must be a Class 1 space.
	Where the gross square footage of the floor exceeds 100,000 sq ft, 12 bicycle spaces are required of at which at least 4 must be Class 1 spaces.
New commercial buildings whose primary use consists of parking spaces for rent or other fee to the general public, and facilities which offer automobile parking space solely to building tenants, or a combination of both.	Every garage shall supply a minimum of 6 bicycle spaces regardless of the number of automobile spaces
	Where the number of automobile spaces is between 120 and 500, 1 bicycle space shall be provided for every 20 auto spaces
	Where the number of auto spaces is more than 500, 25 bicycle spaces shall be provided plus 1 additional space for every 40 auto spaces over 500 spaces, up to a maximum of 50 bicycle spaces





Precedent – Car-share parking spaces.



Precedent – Car-share vehicle.

**Car-sharing** – Local car-share organizations will have access to both on-street and off-street parking in order to provide car-share vehicles throughout the Project site. Car-share services are intended to reduce the overall parking demand by reducing the need for private vehicle ownership. Car-share vehicles are owned and maintained by the car-share service; members access vehicles when needed, paying based on how much they drive.

If it is demonstrated to the satisfaction of the Agency that no certified car-share organization can make use of the dedicated car-share parking spaces, the spaces may be occupied by non-car share vehicles; provided, however, that upon (90) days of advance written notice to the property owner from a certified car-sharing organization, the property owner shall terminate any non-car-sharing leases for leases for such spaces and shall make the spaces available to the car-share organization for its use of such space.

- Required Car-share Spaces – For new buildings, car-share spaces shall be provided as follows:

Table 4.10 Required Car-share/Residential

RESIDENTIAL UNITS	REQUIRED CAR-SHARE PARKING SPACES
0 - 49	0
50 - 200	1
201 or more	2, plus 1 for every 200 additional dwelling units over 200

Table 4.11 Required Car-share/Non-residential

PROVIDED NON-RESIDENTIAL PARKING SPACES	REQUIRED CAR-SHARE PARKING SPACES
0 - 24	0
25 - 49	1
50 or more	1, plus 1 for every 50 additional parking spaces over 50

- Location – Required car-share vehicle spaces shall be located within 800 ft of the building site. Spaces may be located on-street or off-street at the discretion of the Executive Director.

**Unbundled Residential Parking** – With the exception of stand-alone affordable housing developments, in all residential developments with more than 10 units excluding individually parked townhomes, residential parking shall be unbundled and sold or leased separately from units. Unbundling parking makes the cost of parking visible to households, and may encourage some residents to save money by opting for a single off-street space or no dedicated parking.



Precedent – Angled retail parking.



Precedent – Parallel parking.

## 4.5.2 On-street Parking

### Intent

On-street parking will be provided in select street locations for the short term convenience of residents and visitors.

### Standards

**Location** – Parking for the use of the general public shall be provided on the streets shown in Figure 4.15.

### Guidelines

**Parking Bays** – Curb bulb-outs that define on-street parking zones are encouraged where possible.

Figure 4.13 On-street Parking Locations

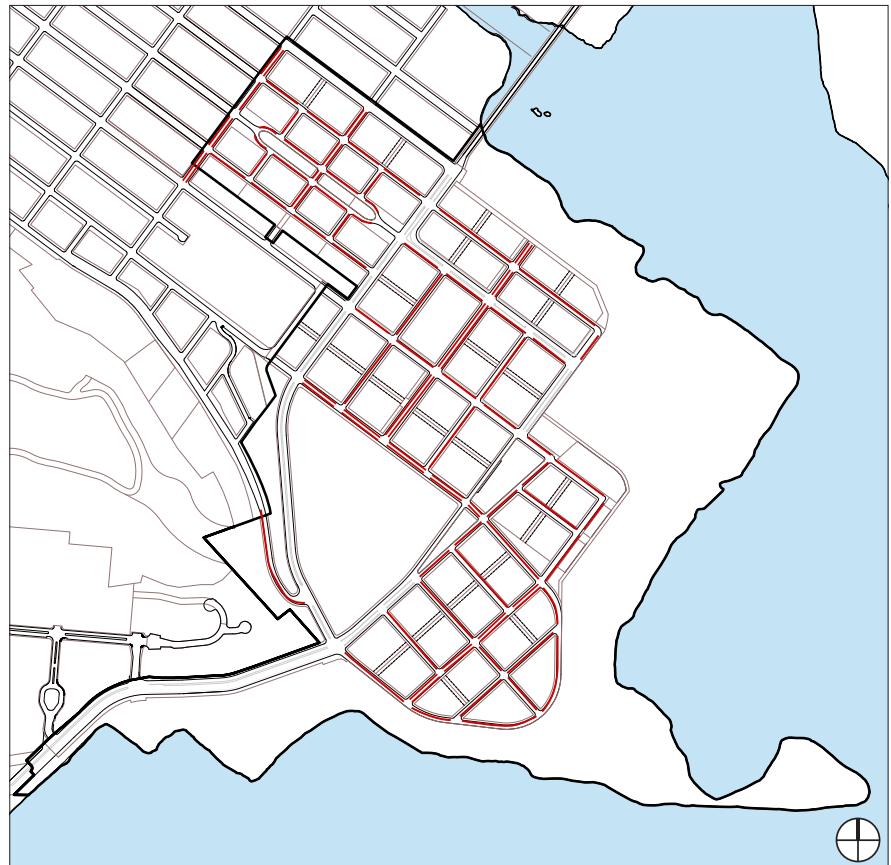

**Legend**  
— On-Street Parking

**Notes:**

1. Additional information concerning on-street parking locations may be included in the final Candlestick Point Hunters Point Shipyard Phase II (CPHPS2) Transportation Plan (available at <https://sfocii.org/candlestick-point-hunters-point-shipyard-phase-2-project-documents>).
2. Refer to Section 5.3 for additional information regarding Internal Private Streets in Candlestick Center.

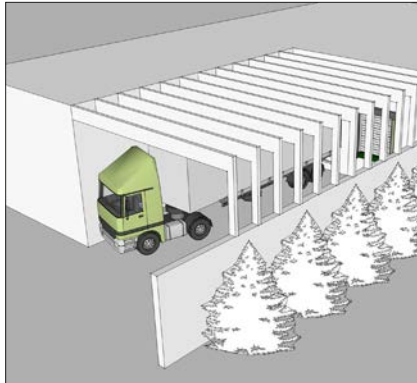

Screen loading areas.



Precedent – Loading located on short side of block.

### 4.5.3 Loading, Mechanical Equipment and Meters

#### Intent

The service component of buildings should be shielded from view of primary public areas such as significant streets and parks. Additional standards for Candlestick Center are provided in Section 5.3.

#### Standards

**Off-street Loading Areas** – Off-street loading spaces are not required for residential and retail uses. If off-street loading spaces are supplied, they shall be a minimum length of 35 ft, minimum width of 12 ft, and minimum height of 14 ft and they shall not exceed 59 spaces for the entire Candlestick project. Where off-street loading spaces are not supplied on-street curb management practices must be utilized, meaning there shall be no disruption to transit operations or auto traffic at peak travel times or on critical routes.

**Location** – Loading areas and utility meters shall be located on mid-block breaks where possible. Where there is no mid-block break, locate loading and meters on the short dimension of the block.

**Curb Cuts** – The maximum width of a curb cut shall be 24 ft. This may be increased to a maximum of 27 ft where:

- access to off-street parking and loading is shared; or
- the extra width is needed to accommodate the fleet of emergency services or utility providers.

Curb cuts shall be a minimum of 30 ft from the end of a street corner radius.

**Screening** – Loading areas, trash storage and mechanical equipment and meters shall be enclosed within structures and hidden from view of the public realm.

#### Guidelines

**Shared Entrances** – Shared loading and parking entrances are encouraged.

### 4.5.4 Temporary Parking

#### Intent

Temporary Parking may be provided as an interim use on portions of the Candlestick site to serve permanent uses whose permanent parking facilities have not yet been completed.

#### Standards

**Parking Space Delineation** – All required vehicle parking spaces shall be clearly marked with paint or other easily distinguishable material.

**Lighting** – Parking areas should have adequate lighting to ensure safety while preventing glare or direct illumination into any adjacent residential buildings.

**Drainage** – All areas of parking shall be graded to convey surface water consistent with the Shipyard Candlestick SWPP Plan.





Precedent – Plaza bench.



Precedent – Sidewalk bench.



Precedent – Bike rack.

**Setbacks** – Setback on lots shall match residential setbacks to provide greenspace and stormwater treatment.

## 4.6 Streets

Street standards are set forth for streetscape (furnishings) aspects of public streets. Section 3.2 contains conceptual illustrations for the various primary street types, while additional standards controlling other aspects of the street such as the width of rights of way, lanes and sidewalks are contained in the Transportation Plan. Standards are also set forth herein for mid-block breaks, which are public easements on private land. Private Street and Paseo standards for Candlestick Center are found in Sections 5.3.3 and 5.3.11.

### 4.6.1 Streetscape

*Note: Because construction of the project will occur over a period of many years Master Specifications are recommended to insure consistency of design, materials, and construction quality over the long range build-out of the project. Master specifications, based on the Streetscape Master Plan, have been developed with the design of the first phase of the project.*

#### Standards

**Sidewalks** – Standard sidewalk paving shall be concrete. Sidewalk paving shall also include special treatments such as concrete with integral color, special scoring patterns, and special finishes, or unit pavers.

**Curb/Gutter** – Standard curb/gutter shall be concrete per City Standard. In certain areas, curb and gutters may include special features such as wider curb widths, integral color and special finishes, or use of stone.

**BRT Lanes** – BRT lanes shall be distinguished by special paving that may be concrete with integral color and special texture or colored asphalt. In some areas BRT lanes may also include planted strips between tire tracks.

**Sustainable Landscaping** – Street landscaping shall consist of native and regionally appropriate planting. Street landscaping shall be strategically planted to help regulate climate, control stormwater, cleanse air and water, and provide habitat.

**Trash/Recycling/Compost Receptacles** – Shall be provided on retail streets, bus stops and in furnishing zones or on bulb-outs near the street corner.

**Benches and seating** – Shall be provided on retail and park boulevard streets and in bulb-out areas. Benches and seating should be oriented to create social spaces. Additionally, locate seating along steep streets and paths to provide a place to rest.



Precedent – Pedestrian scale lighting.



Precedent – Vehicle scale lighting.

### Bicycle Racks

- On public streets, provide bicycle racks on streets fronted by retail, commercial, multi-unit housing, and public service buildings. Additionally, provide bicycle racks adjacent to transit stops, and park entrances.
- Locate bicycle racks in the furnishing zone and on bulb-outs or curb-extensions so that parked bicycles do not block the pedestrian throughway.

### Newspaper Racks

- If newspaper racks are installed, they shall be installed in retail zones and near transit stops, located in the furnishings zone or on bulb-outs.

### Tree Grates

- Use tree grates where pedestrian traffic is high and where sidewalk space is limited.

### Utility vaults

- Locate utility vaults in the furnishings zone where possible. Group and arrange vault covers in an orderly fashion.

### Street Lighting

- Locate street lighting in the furnishing zone.
- Lamps should use high-efficiency technology such as LED to minimize energy consumption.
- Design lighting to maximize public safety while minimizing light pollution.

### Guidelines

**Permeable Parking Lanes** – Permeable parking lanes may be porous asphalt, porous concrete, permeable pavers, or concrete-grass-block grid.

**Special Crosswalks** – Special crosswalk paving may be colored, imprinted asphalt, concrete with integral color and special texture, or unit pavers. Raised crosswalks are encouraged where they will not impede transit or truck routes.

**Customized Style** – Elements and furnishings such as bicycle racks, tree grates, benches and lighting are encouraged to be customized.



Precedent – Residential pedestrian mews.



Precedent – Residential vehicular laneway.

## 4.6.2 Mid-block Breaks

Mid-block breaks are intended to allow public access through the middle of private development block in order to create a more porous circulation system and decrease the scale of building massing.

### Residential

#### Intent

The mid-block break will be a public easement on the private land of the development block. The easement may be developed as either a pedestrian mews or a vehicular laneway at the discretion of the developer.

#### Standards

**Mews vs. Laneway** – All mid-block breaks shall be either pedestrian mews or vehicular laneways or a combination of both. The Streetscape Master Plan has identified specific mid-block breaks defined pedestrian ‘paths to water’ that must at all times maintain a minimum 10 ft pedestrian way. These pedestrian ways may be separate from, or included within, the 20 ft emergency vehicle access.

**Public Access** – Mid-block breaks shall have unrestricted public access.

**Building Face-to-face Dimension** – The minimum building face-to-face dimension, exclusive of projections, shall be 40 ft.

**Path Dimension** – The minimum pedestrian path dimension for pedestrian mews shall be 10 ft.

**Drive Aisle Dimension** – The maximum drive aisle dimension for vehicular laneways shall be 16 ft.

#### Garage Entrances

- Garage entrances to individual units shall be restricted to one per unit at a maximum width of 8 ft.
- Garage entrances to common parking structures shall be regulated per Section 4.3.1 D.
- Garage entrances for all types cumulatively shall be restricted to no more than 45% of the block face.
- Garage entrances shall not extend beyond the main building face; garage entrances that are recessed behind the building face are encouraged.

**Grade Elevation** – Paths and drive aisles shall be at the grade of the public sidewalk.

**Surfaces** – Hard surfaces shall be restricted to 70% of the ground plane.

**Street Trees** – A double row of street trees shall be planted at a spacing that is encouraged to match the town home modules, and in any case is not greater than 30 ft on center.





Precedent – Commercial mid-block break.

**Main Entrance** – The main entrance to the unit shall be located on the mid-block break side of the building.

**Activation** – The street level building face that is not garage shall be activated with ample glazing, entrances, stoops and porches.

**Lighting** – Adequate lighting shall be provided to ensure pedestrian and vehicular safety.

### Guidelines

**Entrance Elements** – Entrance elements that reinforce the main unit entrance such as porches, stoops and terraces are encouraged.

**Community Spaces** – Social spaces, seating and places for informal play are encouraged.

**Landscaping** – The mid-block break is intended to be an outdoor room. Rich landscaping is encouraged so that the drive aisle (in the case of a vehicular laneway) is subordinate. This includes street trees, shrub beds, patios and steps, benches and lighting.

**Permeable Ground** – Permeable paving and stormwater gardens are encouraged.

**Minimizing Vehicle Speeds** – Features to reduce vehicle speeds are encouraged, such as narrow drive aisle and offsets in the drive aisle alignment.

## Commercial

### Intent

Commercial mid-block breaks are intended to allow public access through the middle of private development blocks and meet the requirements of the adjacent building. The mid-block break will be a public easement on the private land of the development block.

### Standards

**Pedestrian Access** – All mid-block breaks shall provide a minimum 10 ft pedestrian only access in the form of a grade separated sidewalk along the entire length of the break. The access can be configured as two 5 ft sidewalks on either side of the mid-block break, or as one 10 ft sidewalk.

**Public Access** – Mid-block breaks shall have unrestricted public access.

**Street Trees** – Street trees shall be planted at a spacing of no more than 30 ft on center within the pedestrian access zone, and shall serve as a buffer between the sidewalk and vehicular lane(s).

---

### **Garage & Loading Entrances**

- Garage & loading entrances shall be no more than 20% of the block face.
- Garage & loading entrances shall not extend beyond the main building face; and are encouraged to be recessed behind the building face.
- Garage & loading entrances shall not be closer than 20 ft to the corner of the building at the entry to the mid-block break.

**Grade Elevation** – Paths and drive aisles shall be at the grade of the public sidewalk.

**Building Face-to-face dimension** – The minimum building face-to-face dimension, exclusive of projections, shall be 40 ft.

**Drive Aisle Dimension** – The minimum drive aisle dimension for vehicular laneways shall be: 20 ft for two-way laneways; 16 ft for one-way laneways.

**Lighting** – Adequate lighting shall be provided to ensure pedestrian and vehicular safety.

### **Guidelines**

**Activation** – The corners of mid-block breaks should be active. Commercial activities are encouraged to wrap the corner to a minimum of 20 feet into the mid-block break.

**Permeable Ground** – Permeable paving and stormwater gardens are encouraged.

**Minimizing Vehicle Speeds** – Features to minimize vehicle speeds are encouraged.

## Mid-block Break Residential

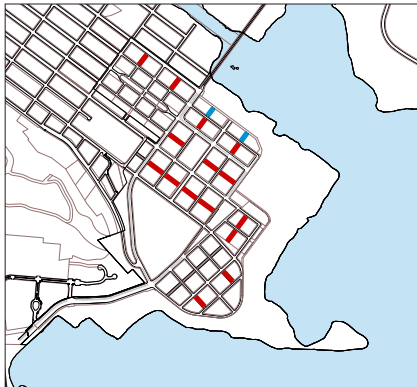

— Mews only      — Mews or Laneway

Pedestrian Mews.

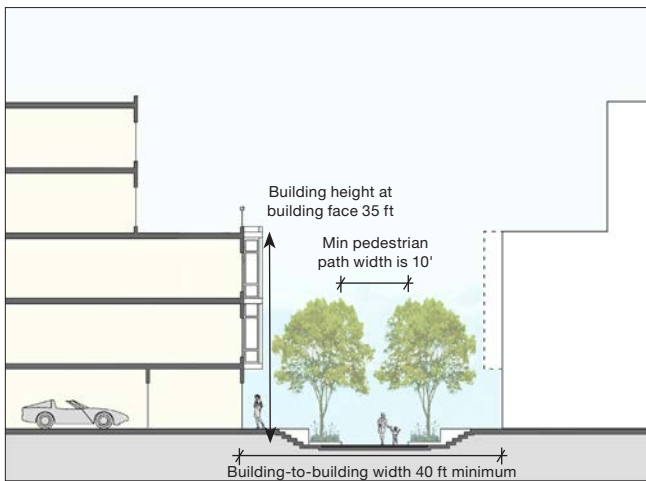

Vehicular Laneway.

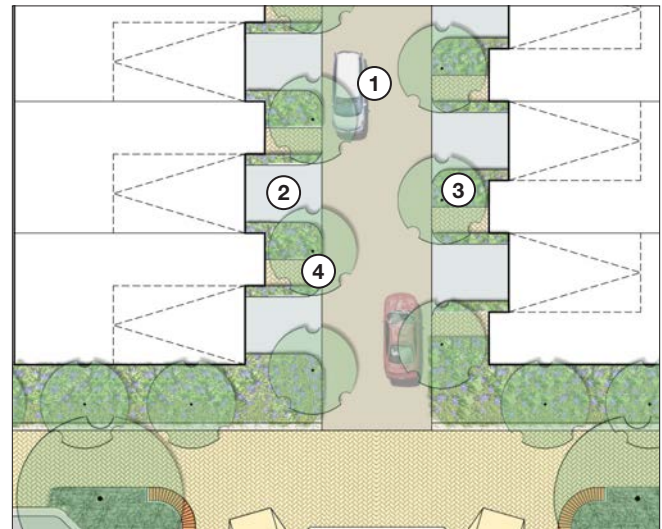
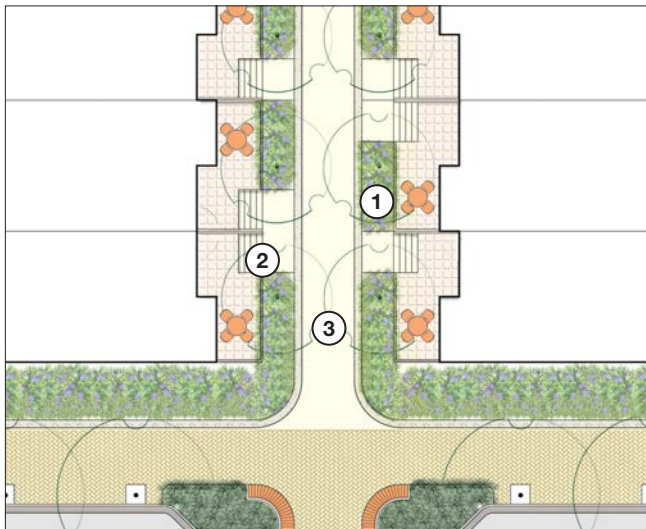
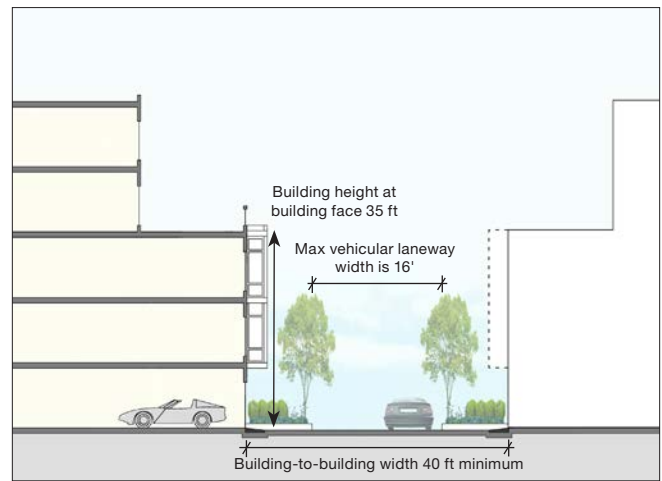

### Legend

- ① Pedestrian Path – min 10 ft width; at grade of public sidewalk
- ② Elevated Private Patio
- ③ Landscape buffer including street trees at max spacing of 30 ft on center.

### Legend

- ① Drive Aisle – max 16 ft width; at grade of public sidewalk
- ② Driveway
- ③ Landscape buffer including street trees at max spacing of 30 ft on center.
- ④ Pedestrian Entrance



**PAGE LEFT INTENTIONALLY BLANK**

# 5





# Neighborhood Standards and Guidelines

- 5.1 Alice Griffith
- 5.2 Candlestick North
- 5.3 Candlestick Center
- 5.4 Candlestick South



## 5 Neighborhood Standards and Guidelines

### General

#### Section Summary

This section describes the standards and guidelines that are specific to the five "character" neighborhoods within Candlestick Point. Each neighborhood is described in terms of its general character, design rationale, standards and guidelines, and any special studies which have been undertaken as a means of testing the neighborhoods standards and guidelines.

#### Neighborhoods Summary

There are five distinct character neighborhoods at Candlestick as shown in Figure 5.1. They are designed to have a range of building types, from predominantly low-rise in Alice Griffith to a blend of taller buildings including high-rises at the confluence of Candlestick North, South and Center. Across all five neighborhoods the ground floor will be activated with residential or commercial uses, thereby enhancing the pedestrian experience and creating a unique sense of place. Each neighborhood has defining open spaces, including parks and urban plazas. The neighborhoods are:

**Alice Griffith** – serves as a linkage between the development and the surrounding Bayview neighborhood. Heights have been kept low to mesh with the surrounding urban fabric. The Bayview street grid extends through the site in order to express the connectivity to adjacent blocks and eliminate the existing 'island' of public housing that is disconnected from the adjacent neighborhood.

**Candlestick North** – has a mixture of housing types and heights. A vibrant retail main street lies to the south of the neighborhood, while two major parks are included with a range of uses. Mid-rise and high-rise buildings frame important open spaces; up to six high-rise towers take advantage of spectacular views over the parks and Bay beyond.

**Candlestick Center** – is the mixed-use core of the Candlestick development. An economic and jobs backbone, Candlestick Center has a mix of neighborhood and regional retail, commercial, housing, a hotel site, and public plazas.

**Candlestick South** – has five high-rise towers concentrated towards its north side, but maintains an intimate scale in response to the State Recreation Area through smaller scaled buildings along its south and east park sides. A small wedge shaped park links the neighborhood with the State Recreation Area beach zone.

Block plans indicating dimensions and parcel areas for each of the neighborhoods are included in Appendix B.

Figure 5.1 Character Neighborhoods

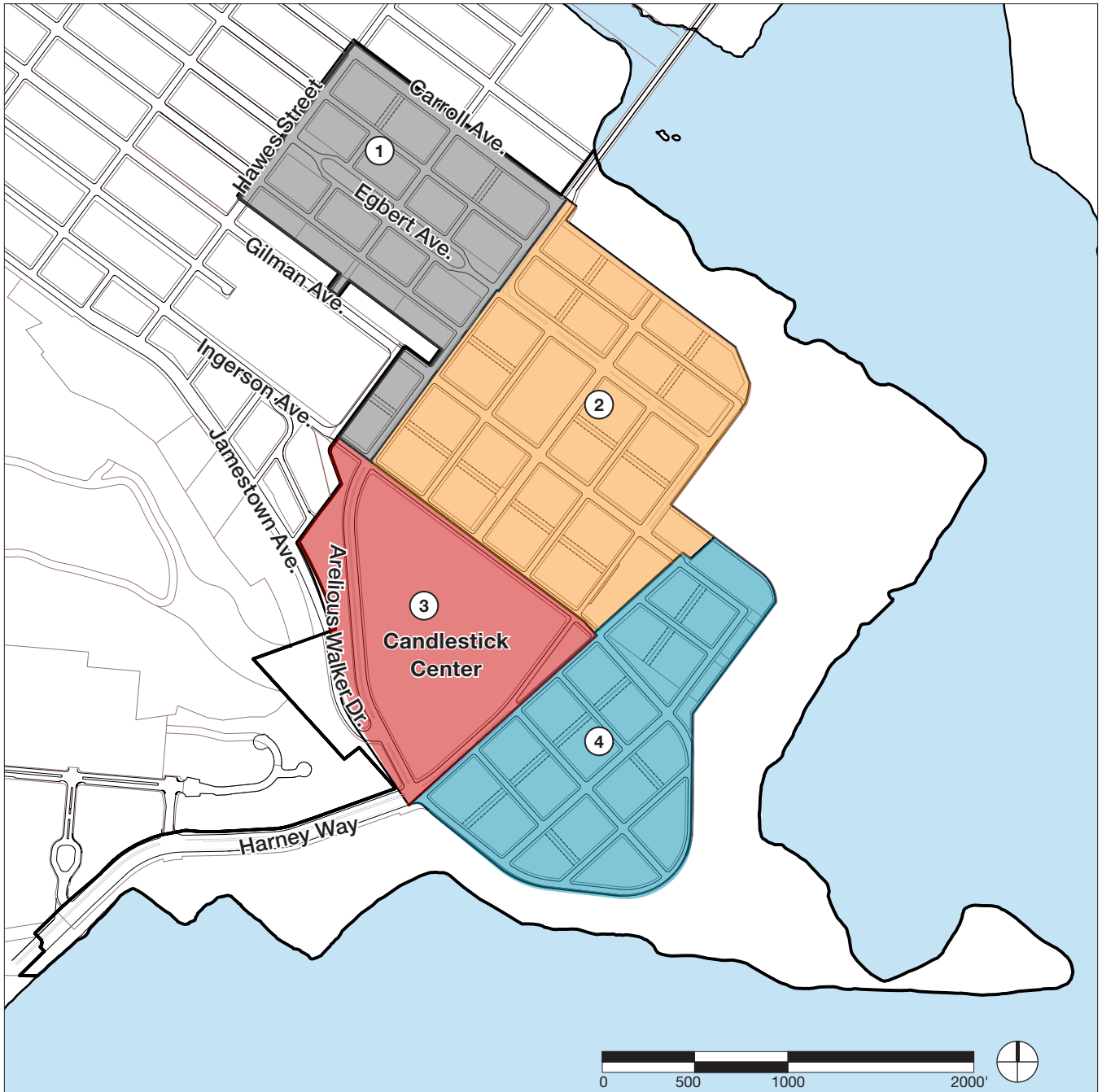

Legend

- ① Alice Griffith
- ② Candlestick North
- ③ Candlestick Center
- ④ Candlestick South

# 5.1 Alice Griffith

---

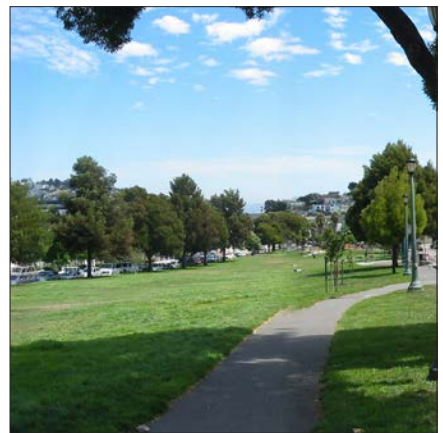
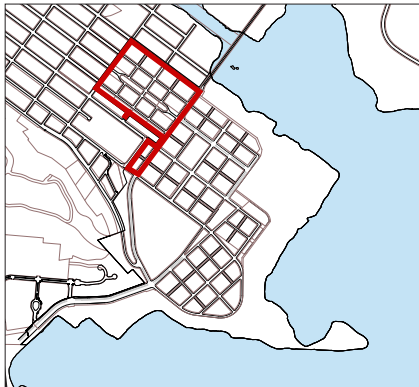







Precedent – Park street.



Precedent – Four to five story residential buildings.



Precedent – Low-rise residential building.



Precedent – Internal courtyard.

### 5.1.1 Alice Griffith – General Description

Alice Griffith community, located north of Arelious Walker Drive, is currently the home of a public housing community. The site will be transformed into a mixed-income community with a diverse range of housing types and better connections to the surrounding neighborhood. The existing number of affordable homes will be fully replaced on site in a phased sequence that ensures residents can move directly into new homes without displacement.

**Land Use / Built Form** – Alice Griffith will be a predominantly residential neighborhood. Buildings will generally be four to five stories along streets, with two and three story townhomes along alleyways. Building façades will be articulated in order to maintain a fine-grained scale. The existing highly terraced topography will be re-contoured at more consistent grades in order to facilitate mobility and development.

**Open Space** – The focus of the community is the centrally located community park that stretches almost the length of the neighborhood, bisected by Griffith Street. It may contain community gardens, tot lots, sports courts, picnic areas and other amenities. Egbert Avenue will become a one-way couplet surrounding the park. The residential buildings fronting this street will be the highest in the neighborhood, providing a streetwall that frames and defines the edges of the park.

In addition, opportunities for outdoor seating associated with commercial and community uses, as well as public art, are encouraged within the large sidewalk areas at the northern and southern ends of Egbert Ave.

**Streets** – The existing grid of streets (Carroll, Donner, Egbert, Fitzgerald, and Gilman running north/south and Griffith running east/west) will be extended through the site, thereby connecting the community back into the larger Bayview fabric. Egbert Avenue is configured as a large parkway, with parallel parking and Class II bike lanes on each side. Arelious Walker Drive serves as the primary truck and auto route between Highway 101 to the south and Candlestick. Wide sidewalks along Arelious Walker Drive serve to connect the two southernmost blocks to the remainder of the neighborhood.









Most steep grades and hills that are barriers to pedestrian and vehicular movement will be removed; mid-block breaks (small local streets, laneways or pedestrian mews) are required on parcels with restrictive grading, creating pedestrian linkages from the central Alice Griffith Community Park to the State Recreation Area system and Gilman Park.



Figure 5.2 Alice Griffith Illustrative Site Plan



Legend

- |   |   |   |                                  |
|---|---|---|----------------------------------|
|  | Low-rise Residential                    |  | Gilman Park                      |
|  | Alice Griffith Community Park           |  | BRT Stop                         |
|  | Candlestick Point State Recreation Area |  | Yosemite Slough Restoration Site |
|  | Candlestick Community Park              |   |                                  |
|  | Candlestick North Neighborhood          |   |                                  |





Conceptual design – Stacked flats along community park.



Precedent – Community gardens in park.



Precedent – Low-rise townhomes along local street.





View of Alice Griffith looking south.

## 5.1.2 Alice Griffith – Urban Design

Refer to Figure 5.3 for the location of the following standards and guidelines.

A block plan indicating dimensions and parcel areas is included in Appendix B.

### Standards

#### S1. Street Wall Height

- Minimum height 40 ft – A street wall to a minimum of 40 ft shall be built on all blocks that front Alice Griffith Community Park.
- Proposition K – Blocks 6 and 7 shall have a maximum height of 40 ft to assure no shadows on Gilman Park except as permitted by Proposition K.

#### S2. Mid-block Breaks

- Shall be provided on the blocks indicated on Figure 5.3 – the precise location may vary from what is shown.

#### S3. Griffith Street Public Access from Gilman Ave

- Public entry to and from the site along Griffith Street between blocks 8 and 14 shall be either a public street or pedestrian-only path based on final grading.

#### S4. Setbacks to Donner Avenue, Fitzgerald Avenue & G Street

- Development blocks 1, 2, 11, 12, 17, 18, 19 and 20 on Donner Avenue, development blocks 4, 5, 8, 9, 13, 14, 15 and 16 on Fitzgerald Avenue, and development blocks 2, 4, 9 and 11 on G Street shall have a minimum building setback of 9ft.

### Guidelines

#### G1. Mid-block Breaks – Pedestrian mews are preferable to laneways.

#### G2. Building Heights

- Building heights should be varied within the district, with shorter buildings along Hawes Street, the southwesterly side of Fitzgerald Avenue and the northern portion of Carroll Avenue to serve as a transition to the surrounding neighborhood. Taller buildings should be built along the community park, up to a maximum of six stories.

#### G3. Encouraged Ground Floor Commercial/Community Use

- Additional ground floor commercial, community space or live/work units are encouraged around BRT transit stops, benefiting transit users and residents, and at the northern end of Egbert Avenue. Encouraged use is neighborhood-serving retail and/or community space.

#### G4. Important Intersections

- The corner of Arelious Walker Drive and Carroll Avenue is a gateway into the site. Architectural elements should be utilized to accentuate and differentiate this entry point.

#### G5. Gilman Properties Interface

- Building design on Blocks 5, 8, 14, and 15 should respect backyards of existing homes on Gilman by providing adequate setbacks.



Figure 5.3 Alice Griffith Urban Design



Legend

- S1 – Residential Street Wall 40 ft Minimum
- S2/G1 – Mid-block Break (pedestrian mews or vehicular laneways)
- S3 – Griffith Street – Public Right-of-Way (pedestrian or vehicular way)
- S4 – Setbacks to Donner Avenue, Fitzgerald Avenue & G Street
- Parks
- G3 – Encouraged Ground Floor Commercial or Community Facilities Space
- G4 – Important Intersections
- # Block Numbers

*Note: The neighborhood/site boundaries and street names indicated on this figure are out of date. Please refer to Figure 2.8 in the D4D containing up to date information. Street names within Candlestick Center are for identification purposes only, and will be confirmed through Major Phase Application/Sub-Phase Application.*

## 5.2 Candlestick North

---











Precedent – Park Street.



Precedent – Mid-block break.



Precedent – Residential patio zone.

## 5.2.1 Candlestick North – General Description

Candlestick North is a compact mixed-use community with the greatest number of homes in Candlestick, animated neighborhood streets, and engaging parks and a main street filled with shops and services.

**Land Use / Built Form** – The neighborhood contains a mix of low-rise, mid-rise and high-rise mixed-use and residential buildings that frame and focus civic life on the parks and streets. Mixed-use buildings along the main street (Ingerson Avenue) create an animated retail atmosphere. Eight to ten story residential buildings frame the Bayview Gardens Wedge Park, while shorter residential buildings line both park streets (Egbert Avenue and Earl Street) and the central Candlestick Community Park.

Up to six towers are strategically located to overlook the Candlestick Community and Wedge Parks, and to emphasize key intersections within the plan. Low-rise residential buildings make up the majority of remaining buildings, including two and three story townhomes along mid-block breaks that establish a more intimate pedestrian scale. Additional retail opportunities are located in the bases of buildings at the BRT stops on both ends of the community and along the Wedge Park.

**Open Space** – Parks and open spaces are plentiful; almost all blocks are adjacent to open space. The Bayview Gardens Wedge Park and State Recreation Area surround the bay sides of the neighborhood. A three-acre Candlestick Community Park will be located near its center; the final location of this park will be determined in the future. The parks meet the needs of residents and visitors, and offer a distinctly urban character compared to the more naturalized character of the State Recreation Area.













Two ‘Park Streets’, Egbert Avenue and Earl Street, run perpendicular through the neighborhood. The park streets provide breathing room within the plan, while serving as sustainable elements.

**Streets** – Streets vary considerably in character. The dynamic main street (Ingerson Avenue) has on-street parking and broad sidewalks with plaza zones. Ingerson is designed to accommodate high pedestrian and bicycle traffic, in addition to automobile uses. The Egbert Avenue and Earl Street parkways run through the center of the neighborhood, linking the adjacent communities of Alice Griffith and Candlestick Center and providing views to the Bay. Arelious Walker Drive is the main truck and auto route through the development. It has large sidewalks, medians, bike lanes, and parallel parking to buffer residential uses. A BRT street runs on Harney Way along the north edge of the Wedge Park then northward on Egbert Avenue to Arelious Walker Drive, linking Candlestick to the Shipyard and the Bayshore Caltrain Station. Local streets have bulb-outs, ample pedestrian crossings, and other traffic calming measures. Generous, tree-lined sidewalks and building setbacks provide a stoop or terrace transition between homes and the street. Pedestrian mews or vehicular laneways at mid-block create additional linkages to the Bay.

Figure 5.4 Candlestick North Illustrative Site Plan



**Legend**

- |   |   |
|---|---|
|  Low-rise Residential  |  Candlestick Point State Recreation Area |
|  Mid-rise Residential  |  Bayview Gardens/Wedge Destination Park  |
|  High-rise Tower   |  Candlestick Center Neighborhood         |
|  Mixed-use   |  Candlestick South Neighborhood          |
|  Alice Griffith Community Park   |  BRT Stops                               |
|  Alice Griffith Neighborhood   |   |
|  Candlestick Community Park<br>(Final Location to be determined in the future.<br>See Section 3.3 for location criteria) |   |





Precedent – Community park.



Precedent – Retail and sidewalk on Ingerson Avenue.

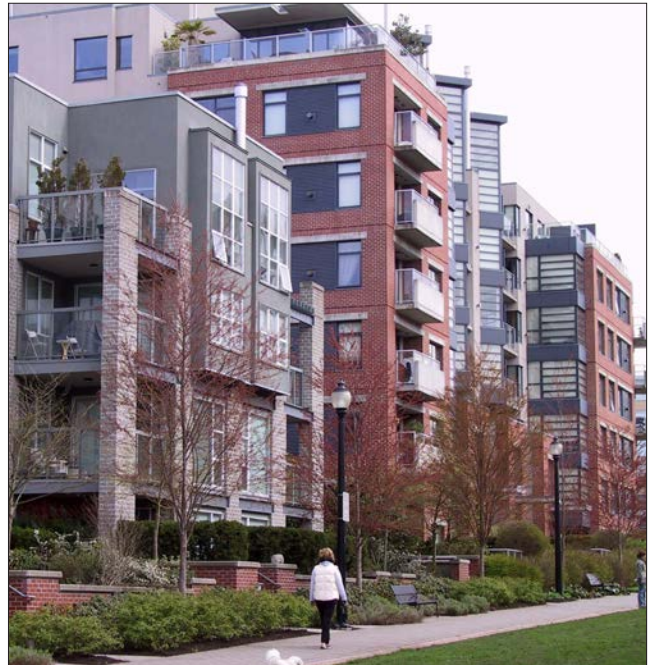

Precedent – Residential buildings fronting park street.





View of Candlestick North looking west.

*Note: Towers shown are one example of allowable tower locations (see Section 4.2.2 for details).*

## 5.2.2 Candlestick North – Urban Design

Refer to Figure 5.5 for the location of the following standards and guidelines.

A block plan indicating dimensions and parcel areas is included in Appendix B.

### Standards

#### S1. Mixed-use Zone / Required Ground Floor Commercial

- Ingerson Avenue shall be a mixed-use zone along its frontage within the neighborhood.
- Ground floor use on Ingerson Avenue shall be commercial; retail is encouraged; live/work is allowed.

#### S2. Minimum Street Wall Heights

- Minimum height 35 ft – A street wall to a minimum of 35 ft shall be built fronting the entirety of Ingerson Avenue.
- Minimum Height 40 ft – A street wall to a minimum of 40 ft shall be built along the entirety of Earl Street, Egbert Avenue, and surrounding the community park
- Minimum height 60 ft – A street wall to a minimum of 60 ft shall be built on Block 7b along the park edge, and on blocks 8a and 8b fronting Earl Street.
- Minimum height 80 ft – A continuous street wall to a minimum of 80 ft shall be built fronting the Bayview Gardens Wedge Park on Blocks 9a, 9b, 11a, and 11b.

#### S3. Towers

- Towers shall be located within the tower zones described in Section 4.2.2 Heights. If moved from the preferred location, towers shall be sited fronting major streets and/or frame parks and important public places, and shall require a shadow and wind analysis as per Section 4.2.6 and Section 4.2.5 respectively.
- No more than 6 towers shall be located within Candlestick North neighborhood. The towers on blocks 7b and 11a, if developed, shall not be relocated from the position shown. All other towers may be relocated within the allowable tower zone. Shown in Section 4.2.

**S4. Mid-block Breaks** – Shall be provided within the blocks indicated on Figure 5.5. The breaks on Block 5 and 6 shall be pedestrian mews; laneways are prohibited. The precise location of the mid-block breaks shown on Figure 5.5 may vary slightly from what is shown, however they are mandatory for the block.

**S5. City Park**

- A City Park of approximately 3 acres shall be provided within the central portion of the neighborhood. The final location of the park will be determined in the future, and will depend on which parcels within Candlestick North are acquired for development. See Section 3.3 for general criteria, currently shown on Block 12 for illustrative purposes.

**S6. State Park Edge**

- A publicly accessible walkway/emergency access shall be provided as shown in Figure 4.11.

**Guidelines****G1. Encouraged Ground Floor Commercial**

- Additional ground floor commercial is encouraged around BRT transit stops, benefiting transit users and residents. Encouraged use is neighborhood-serving retail.

**G2. Important Intersections**

- The corners of Arelious Walker Drive/Ingerson Avenue, Harney Way/Ingerson Avenue, Carroll Avenue/Arelious Walker Drive are important intersections, serving as either gateways into the site or zones of high pedestrian activity. Architectural elements should be utilized to accentuate and distinguish these entry points.

**G3. Grocery Store** – A grocery store, if developed, should be located in a prominent and easily accessible location along Ingerson Avenue. Where necessary to accommodate the grocery store’s loading dock, the garage door and curb cut width may exceed the maximum standards in Section 4.3.1 D and 4.5.3 where:

- Access to the loading dock and any on-site car parking is combined and located on the O Street frontage;
- Any on-street loading or ADA parking that is impacted by the location of the curb cut on O Street is accommodated in an alternative location in immediate proximity of the site;
- The loading dock is shielded from public view when not in use and designed in a manner that visually integrates with the building’s architecture and street wall; and
- The garage entry and the curb cut is designed in a manner that provides a continual, safe and comfortable crossing for pedestrians and bicyclists along the adjoining public street.







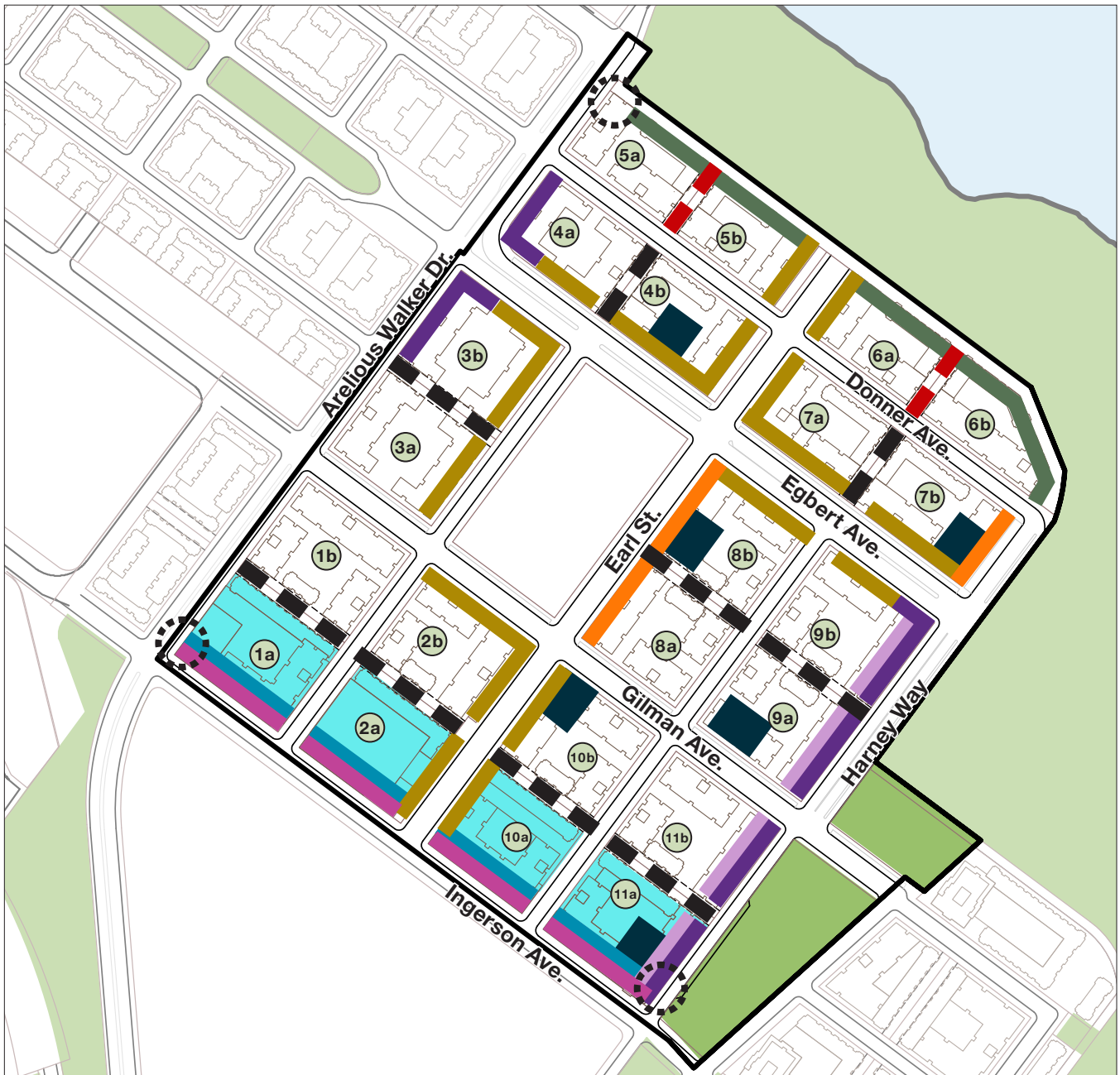







**G4. Mid-block Breaks** – Pedestrian Mews are preferable to laneways to enhance the overall pedestrian circulation network.**G5. Height Variation** – For buildings along Ingerson Avenue and Harney Way, building heights are encouraged to be varied to add architectural interest to the streetscape.



Figure 5.5 Candlestick North – Urban Design



Legend

- |   |   |
|---|---|
|  S1 – Mixed-use Zone/Required Ground Floor Commercial                                    |  S4/G4 – Mid-block Breaks                |
|  S2/G5 – Mixed-use Street Wall 35' Minimum   |  S5 – Parks                              |
|  S2 – Residential Street Wall 40' Minimum  |  S6 – State Park Edge                    |
|  S2 – Residential Street Wall 60' Minimum  |  G1 – Encouraged Ground Floor Commercial |
|  S2 – Residential Street Wall 80' Minimum  |  G2 – Important Intersections            |
|  S3 – Tower Locations (refer to Section 4.2.2 for the location of allowable tower zones) |  G3 – Grocery Store                      |
|  S4 – Mid-block Break – Pedestrian Mews  |  # Block Numbers                         |

**PAGE LEFT INTENTIONALLY BLANK**

## 5.3 Candlestick Center

---

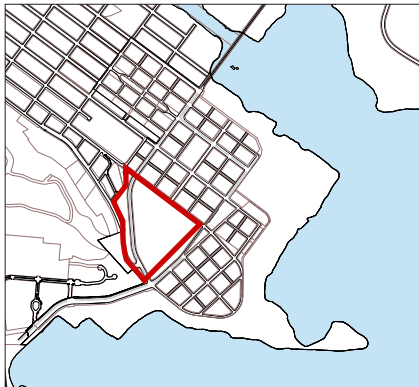

Location of Candlestick Center.



Rendering showing mixed-use and retail frontages along a central spine.



Precedent – Mixed-use building.



Precedent – Pedestrian-oriented street.





Conceptual Rendering of Candlestick Center showing Market Hall and Plaza viewed from Ingerson Avenue.

## 5.3.1 Candlestick Center Standards and Guidelines Introduction

The following sections contain design standards and guidelines applicable to Candlestick Center only. They supplement other standards and guidelines in this D4D which also apply to Candlestick Center. In some cases, detailed below, they supersede other standards and guidelines in this D4D.

### The Section has fifteen parts:

- 5.3.1 Candlestick Center Standards and Guidelines Introduction
- 5.3.2 Candlestick Center General Description
- 5.3.3 Internal Circulation; Private Streets
- 5.3.4 Central Plaza/Entrance Plaza
- 5.3.5 Bulk & Massing
- 5.3.6 Build-to Lines
- 5.3.7 Parking Facilities
- 5.3.8 At-grade Activation
- 5.3.9 Accessibility to Private Streets, Paseos, Plazas; Private Open Space Standards
- 5.3.10 Parking and Service Entries
- 5.3.11 Paseos
- 5.3.12 Enhanced Sidewalks
- 5.3.13 Setback Building and/or Parking Facility; Public Promenade
- 5.3.14 Vista Terminations
- 5.3.15 Skyway Connection

### Intent

Section 5.3 focuses on design standards and guidelines for office buildings, retail buildings and parking facilities in Candlestick Center. These are larger scale building types that benefit from tailored design standards and guidelines. For other building types permissible within Candlestick Center, including residential, the applicable guidelines and standards shall be those established for such building types elsewhere in the D4D and may be supplemented by this Section 5.3 where applicable. In addition, Section 5.3 has design standards and guidelines pertaining to circulation, open space and other subjects that are unique to Candlestick Center.

### Precedence of Standards

- Should there be any conflict between this Section 5.3 and Section 4.2.2 concerning building heights it shall be resolved in favor of Section 4.2.2.
- Should there be any conflict between this Section 5.3 and other Sections regarding Bulk and Massing (including Section 4.2.2) and Building Type (Section 4.3.1) controls for office buildings, retail

buildings, and parking facilities (but not any other building type) within Candlestick Center, this Section 5.3 shall govern. Bulk and Massing controls are defined as those categories of controls found in Section 4.2.3: Bulk and Massing.

- Should there be any conflict between this Section 5.3 and other Sections regarding Street Wall controls for Private Street and Paseos within Candlestick Center, this Section 5.3 shall govern. Street Wall controls are defined as those categories of controls found in Section 4.2.4: Street Wall.
- Should there be any conflict between this Section 5.3 and other Sections regarding the design and location of Private Streets or Paseos within Candlestick Center, this Section 5.3 shall govern.

### 5.3.2 Candlestick Center General Description

Candlestick Center is a focal point for Candlestick Point, featuring a mixed-use neighborhood comprised of retail shops and services, commercial, and residential development, linked by a pedestrian friendly street and Paseo network.

The Candlestick Center site is bound by Harney Way, Ingerson Avenue, and Arelious Walker Drive on three sides. Ingerson Avenue and Harney Way will serve as mixed-use streets that frame the edges of the site. Harney Way will be Candlestick Center's main circulation route for buses, bicycles and vehicles. A network of interior private streets will divide Candlestick Center into blocks and will connect with the surrounding street grid. Some private streets may serve the back-of-house for buildings, as those functions are prohibited on Harney Way and Ingerson Avenue.

A public open space hierarchy is established by a network of a central plaza, an entrance plaza at the intersection of Harney Way and Ingerson Avenue, a public promenade shown along Ingerson Avenue and a variety of linked internal Enhanced Sidewalks, streets, and Paseos.







All development planned within Candlestick Center shall satisfy requirements stated within the Candlestick Point: Hunters Point Shipyard Sustainability Plan.





The illustrative key urban design concepts diagram (Figure 5.6) shows the general location of streets and Paseos along with other urban design concepts such as a signature building, a gateway element, areas of At-grade Activation, plazas and open spaces. In addition, the retail priority zones shown in Figure 5.6 are encouraged to provide a network of ground floor retail uses. While this illustration shows one potential buildout solution, other solutions are possible using the Candlestick Center Design Standards and Guidelines.



Figure 5.6 Candlestick Center Illustrative Diagram for Key Urban Design Concepts



-  Street Network or Emergency Vehicle Access (EVA)
-  Build-To-Lines
-  Required At-grade Activation
-  Retail Priority Zone
-  Central Plaza
-  Location of Pedestrian Paseos
-  Public Promenade

-  Enhanced Sidewalk
-  Optional Paseo
-  Signature Building with Entrance Plaza
-  Gateway Element

*Note: Street names within Candlestick Center are for identification purposes only, and will be confirmed through Major Phase Application/Sub-Phase Application.*

### 5.3.3 Internal Circulation; Private Streets

#### Intent

The intent of these standards is to ensure pedestrian connectivity, including the visibility of desired paths of travel, and the urban framing of these pathways and view corridors with the placement of buildings with complementary Build-to Line and At-grade Activation standards herein. At the perimeter of Candlestick Center, internal Private Streets and/or Paseos will connect with the surrounding public street grid. The internal Private Streets and Paseos will divide Candlestick Center into smaller blocks that are flexibly sized to accommodate different types of development. Internal Private Streets and Paseos may be entitled as easements rather than street rights-of-way.

#### Standards

**Connective Circulation Network** - Pedestrian circulation shall provide a reasonably direct path of pedestrian travel through Candlestick Center to and from intersections of public streets on the Candlestick Center periphery. Private Streets and Paseos in Candlestick Center shall align with streets across Harney Way, Ingerson Avenue and Arelious Walker Drive and shall follow a logical grid in the interior of the Center.

**Private Streets** - Private Streets shall follow the following Standards:

- Internal Private Streets shall have a minimum 46 ft building-to-building width and a maximum average building-to-building width of 80 ft, not counting Paseos, Enhanced Sidewalks, or plazas in the calculation.
- Private Streets shall include 10 ft minimum width sidewalks on both sides of the street. Where Shared Private Streets are provided, they shall be exempted from this standard.
- Private Streets (including Shared Private Streets) shall include a roadway width that shall be no wider than 26 ft but may be less.
- Sidewalks shall be designed to include a walkway zone of no less than 6 ft wide, and a landscape zone no less than 4 ft wide. The landscape zone shall be developed with furnishings, planters, trees, streetlights and benches.
- Private Streets shall be accessible to public at all times.

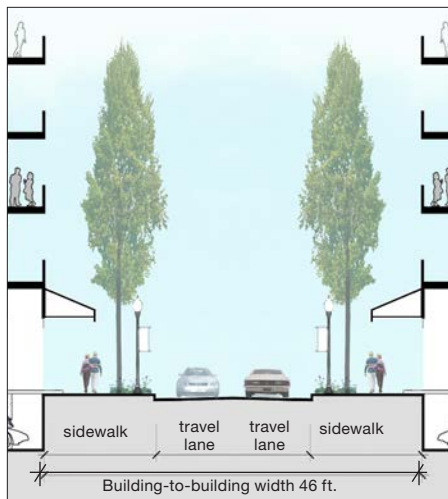

Conceptual Private Street section.

### 5.3.4 Central Plaza/Entrance Plaza

#### Intent

A public central plaza will be located within Candlestick Center to provide a publicly accessible focal point for the site. This plaza shall be sized to serve as a primary gathering space. In addition, there will be an entrance plaza at the intersection of Ingerson Avenue and Harney Way, associated with the Signature Building.





Precedent – Public plaza.



Precedent: Example of plaza.  
Credits: Pancras Square, Townsend Landscape Architects, Photo © John Sturrock.



Precedent: Example of seating for plazas  
Credits: The Rivermark, David Baker Architects, Fletcher Studio, Photo © Mariko Reed.



Precedent: Example of entrance plaza.

### Standards

**Central Plaza** - Candlestick Center shall include at least one public central plaza that meets the following standards:

- The central plaza shall be a minimum of 110 ft wide in the narrowest dimension, with a minimum area of half acre in size.
- Any useable open space (e.g., not fountains, large planters/heavily landscaped areas, or stairways) provided beyond the minimum required area above may be counted towards meeting the Total Open Space Area requirements (as described in Section 4.3.2 F Private Open Space) for adjacent Candlestick Center residential buildings in accordance with Section 5.3.9.
- The central plaza shall be publicly accessible at all times.
- A minimum of 50% of building frontages along the central plaza perimeter (but excluding stairs for the graded slope and sides along streets) shall be Active Uses, such as cafes, restaurants with outdoor seating, and retail.
- Paving shall be distinct, but compatible with the paving of immediately adjacent paseos and integrate with the paving on sidewalks of perimeter Private Streets.
- Trees shall frame views and connections to nearby Paseos, Enhanced Sidewalks and promenades.

**Entrance Plaza** - Candlestick Center shall include an additional plaza at the corner of Harney Way and Ingerson Avenue associated with the Signature Building. Standards for this plaza are in Signature Building Type standards in Section 4.3.1.B.

### Additional Plaza Standards

**Plaza Edges** - Plazas shall be designed with strong edges defined with the help of bollards, striping, stairs, or similar features to distinguish plaza area from vehicular traffic.

**Design Elements** - Plazas may include landscaping, furnishings, and other design elements, such as seating, lighting, water features, distinctive paving, artwork, and bicycle racks. All design elements shall complement the surrounding building architecture.

**Surfaces** - All plazas shall incorporate soft and hardscaped areas.

**Furnishings** - Furniture elements such as tables and chairs may be moveable to provide flexible use of plaza space. Any fixed seating that may be provided within a plaza shall not obstruct pedestrian circulation.

**Lighting** - Adequate pedestrian-scale lighting shall be provided at plaza to ensure pedestrian safety while not being intrusive to adjacent residential units.



### 5.3.5 Bulk & Massing

#### Intent

Unique among neighborhoods in Candlestick Point, Candlestick Center can accommodate buildings with large floor plates and long plan lengths. The following standards establish bulk controls that allow for building shapes that are compatible with the existing surrounding development and proposed adjacent development within Candlestick Point, buildings that do not shade, crowd or otherwise impose upon the pedestrian realm, and that achieve an attractive urban form.

#### Standards

**Development Block Area** - Development blocks within Candlestick Center are defined by their surrounding streets, Paseos, and/or plazas. Enhanced Sidewalks and/or plazas. Development block area equals all land area bounded by a publicly-accessible street, plaza or Paseo. Maximum development block areas are stipulated in Table 5.2 and vary depending on the maximum plan dimension of the development block.

**Bulk Controls** – To establish a connective pedestrian circulation network open to the public, buildings within the Candlestick Center neighborhood shall not exceed the maximum plan dimensions and maximum development block areas stated in Table 5.2. For the purpose of this standard, (1) plan dimension shall be defined as the maximum linear frontage dimension at pedestrian level; and (2) Development Block Area shall be defined as the area enclosed by maximum floorplate at pedestrian level.

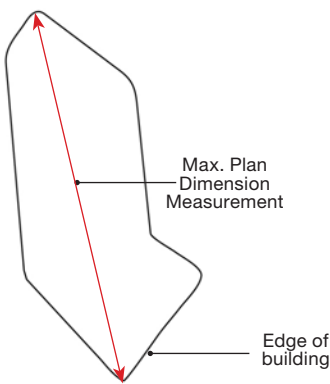

Maximum Plan Dimension Measurement.

**Table 5.2- Maximum Plan Dimension and Development Block Coverage**

	MAXIMUM PLAN DIMENSION	MAXIMUM DEVELOPMENT BLOCK AREA
General standard	350 ft	60,000 sf.ft.
Exception 1 (maximum of 3 buildings)	450 ft	80,000 sf.ft.
Exception 2 (maximum of 2 buildings)	550 ft	100,000 sf.ft.
Exception 3 (maximum of 1 building)	850 ft	150,000 sf.ft.

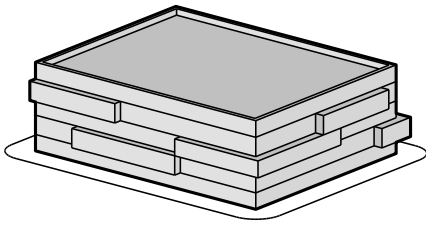

Example of Facade Modulation using horizontal plan shifts.

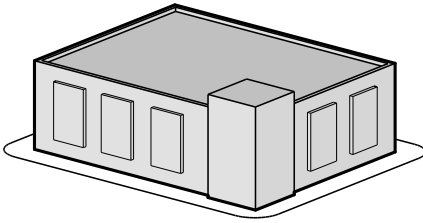

Example of Facade Modulation using vertical plan shifts.



Precedent – Facade Variation with change in material, color, and texture.  
Credits: Koning Eizenberg Architecture, Photo © Eric Staudenmaier.



Precedent: Horizontal Shift in Plan.  
Credits: The Brickyard at Playa Vista, Michael Maltzan Architecture Photo © MMA.

**Massing Controls and Apparent Face** - Facades on Arelious Walker Drive and all interior street-fronting elevations greater than 150 ft in length shall be divided into smaller façade segments or Apparent Faces using one or more of the strategies listed below.

- **Modulation** – Street-fronting elevations of buildings shall apply façade modulation strategies, including horizontal or vertical plan shifts, having a minimum depth of 2 ft. “Vertical Shift” may consist of a façade subdivided into “bays” that recess from the façade. “Horizontal Shift” may consist of building projections.
- **Vertical/Horizontal Articulation and Fenestration** – Vertical/Horizontal Articulation shall include, but not be limited to, vertical or horizontal recesses, shading devices, cornices, openings, window reveals, screening devices, and balconies. Fenestration strategies shall include, but not be limited to, glass curtain wall, boxed or bay windows, glazed atrium, or punched windows.
- **Façade Variation with the help of Material and/Color** – Shall include a change in color and a change in material or a change in application of material such as a pattern and/or texture.
- **Significant Breaks** – Significant Breaks in the form of vertical interruptions shall be used to provide segmentation of building face. An Apparent Face on a Street-Fronting Elevation shall be no greater than 150 ft in length without a Significant Break. Significant Break shall be at least as wide as 10% of the longest adjoining Apparent Face. The minimum Significant Break depth shall be half the width or 8 ft, whichever is less.



Precedent: Example of Articulation and Fenestration Strategies, such as vertical recesses, punched openings, and color variation on facade.  
Credits: One Santa Fe, Michael Maltzan Architecture, KTGy, Gensler, Photo © Photekt.



Precedent: Example of Facade Articulation and fenestration using vertical and horizontal recesses.  
Credits: Cloverdale749, Photographer unknown. © Lorcan O’Herlihy Architects.

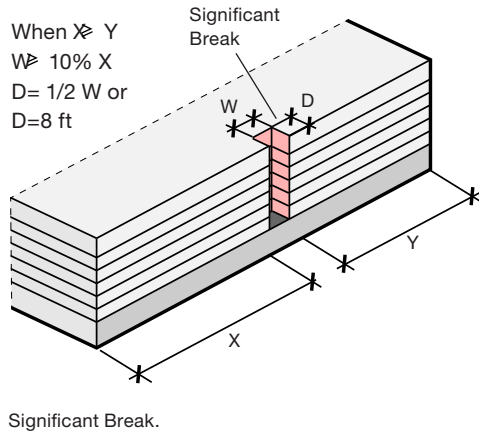

### Upper Floor Stepbacks –

- All commercial buildings including parking facilities (but excluding Signature Building) within Candlestick Center at allowable heights between 85 ft and 120 ft shall stepback at the top floor(s) as follows:
  - » If the average floor to floor height is less than 15 ft, the top two floors on at least one perimeter edge shall step back a total of at least 20% from floor plate immediately below.
  - » If the average floor to floor height is greater than or equal to 15 ft, the top floor on at least one perimeter edge shall step back a total of at least 20% from floor immediately below.

**Datum Expression:** All building frontages within Candlestick Center facing Ingerson Avenue and Harney Way are required to incorporate an architectural expression of an established datum at the 65 ft level. Minor deviations in datum height of 3 ft or less are allowed. This may be achieved by modulation in the building Facade, a change in material, or a different architectural expression.

### 5.3.6 Build-to Lines

#### Intent

The Build-to Line standards within this section establish flexible street walls for buildings facing Private Streets and Paseos within Candlestick Center. Street Wall conditions fronting public streets, such as Ingerson Avenue, Harney Way, and Arelious Walker Drive are regulated in Section 4.2.4.

#### Standards

Build-to Lines shall be measured to edge of sidewalk, Shared Private Street, Enhanced Sidewalk, or Paseo.

**Build-to Line at Private Streets** – A minimum of 65% of building frontage facing Private Streets shall be built to the Build-to Line.

**Promenade** – A building/parking facility located entirely within one block of Ingerson Avenue or Harney Way may be setback from the Build-to Line (refer to standards in Section 4, Figure 4.8) if compliant with the standards in Section 5.3.13.

**Build-to Line at Paseos** – At least 75% of the building frontages along Paseos shall be built to the edge of Paseo. At least 30 ft of building length along the Paseo (measured from each building corner) shall be built to the edge of the Paseo.

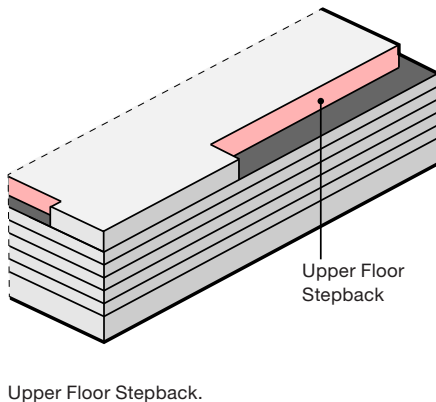





Precedent: Example of enhanced screening at Eskenazi Hospital Parking Garage.  
Credits: Serge Hoeltschi, [https://www.architectmagazine.com/technology/detail/detail-mayseptember-installation-at-eskenazi-hospital-parking-garage\\_o](https://www.architectmagazine.com/technology/detail/detail-mayseptember-installation-at-eskenazi-hospital-parking-garage_o), <https://www.rob-ley.com/may-september>.



Precedent: Example of enhanced screening using graphic facades.  
Credits: CoSM Public Parking Structure, Behnisch Architekten with Studio Jantzen and IPD, Photo © David Matthiessen.



Precedent: Example of enhanced screening with the help of kinetic art.  
Credits: The Bund Finance Center, Foster + Partners and Heatherwick Studio, Photo © Laurian Ghinitoiu.

## 5.3.7 Parking Facilities

### Intent

Parking facilities should be discretely designed to not detract from the urban design quality of the Candlestick Center. Other standards for parking facilities are included in Section 4.3.1 D and Section 4.5.3.

Wrapping is a standard requiring occupiable floor area such as office, retail or residential uses at the perimeter of the building to shield parking facilities from public view. Screening is a standard requiring non-occupiable architectural treatment and/or other visual elements that cover the façade of parking facilities. Screening standards in Candlestick Center are two types: a general screening standard for screening all elevations of Parking Facilities and an enhanced screening standard at prominent locations that need additional facade treatment that is dynamic and heightens visual interest.

### Standards

#### Wrapping for Parking Facilities

- At least 50% of the total façade above the ground floor shall be wrapped, as measured by summing the total area of wrapping of all faces and dividing it by the total area of the facade. In the case that a portion of a façade is stepped back due to other standards or requirements, the area of that façade required to be stepped back shall be counted in the calculation of total façade area.

#### Screening for Parking Facilities

- **General Screening** – General screening of parking facilities, as specified in Section 4.3.1 D, shall be provided on all façades (except those subject to Enhanced Façade requirements) above the ground floor, as well as where At-grade Activation is not required or otherwise provided at the ground floor.
- **Enhanced Screening** - Parking facility facades that are at Vista Terminations or that face public streets that are not required to be or otherwise proposed to be wrapped shall utilize enhanced screening. On such frontages, the interior of the garage is to be minimally visible. Enhanced screening may include murals; art installations; wind sculptures; kinetic art; graphic facades; interactive media facades (to the extent not intrusive on surrounding residential uses); or similar architectural treatments of high visual interest that distinguish the treated façade from adjacent conditions.

### Convertibility of Parking Facilities

- At least one stand-alone parking garage provided within Candlestick Center shall be built as a convertible structure, if feasible. A convertible garage is defined as having clear heights that match those of the adjoining building and has level floor plates.
- The developer may use temporary surface parking within the Candlestick project area, if feasible, until such a time when a structured parking garage becomes necessary (as determined by the developer). See Section 4.5.4 for Temporary Parking standards.

### 5.3.8 At-grade Activation

#### Intent

At-grade Activation is a standard for all buildings in Candlestick Center including the ground floor of parking facilities. An exception is made for building elevations fronting Arelious Walker Drive, where At-grade Activation is not required. The standards below are intended to create an inviting pedestrian environment and to improve neighborhood safety along streets, Paseos, and plazas. Additional activation standards for Paseos, Plazas and promenades are found in their respective sections.

#### Standards

**Active Uses** – Where Active Uses are required, the base of buildings shall animate the streets by containing Active Uses supported by appropriate fenestration, entrances and outdoor spaces at the street level. Some frontages shall have retail priority uses as described below.

**Transparency** – The following transparency standards are applicable anywhere an Active Use is required.

- Glass shall be no more than 10% reflective, with 80% light transmittance, and without tint or coloration. Use of dynamic glazing that transitions from clear to tinted shall be allowed. Opaque glazing shall not be permitted.
- Ground floor frontage of Active Uses on Retail Streets or Retail Priority Streets shall be fenestrated with transparent windows and doors that maximize visibility of building interiors on ground level. Transparent glazing shall occupy 70% of the active frontage, with top of windows to at least 12 feet above grade.
- For commercial building types not on Retail Priority Streets, active frontage shall incorporate no less than 60% transparent glazing in the vertical zone between 4 ft and 8 ft from finished grade level.
- For residential building types not on Retail Priority Streets, active frontage shall incorporate no less than 50% transparent glazing in the vertical zone between 4 ft and 8 ft from finished grade level.
- Residential building lobbies, atria, lounges, and amenity spaces shall incorporate no less than 60% transparent glazing in the vertical zone between 4 ft and 8 ft from finished grade level.



Precedent – Vibrant retail street.



Precedent: At-grade Activation example next to plaza.  
Credits: Photographer unknown, © Runberg Architecture Group, Karen Kiest Landscape Architects.



Precedent: Animated retail street.

**Other At-grade Activation in Candlestick Center** - For buildings facing Private Streets, there shall be at least one entrance along any such Private Street frontage, with a minimum of 30% of transparent glazing for the entire ground floor frontage, and 60% transparent glazing for ground floor lobby and amenity space measured in the area between four and eight feet in height above grade.

**Retail Priority Street** - A Private Street(s) within Candlestick Center shall be a Retail Priority Street, and the total length of said street(s) shall be no less than 850 ft. On Retail Priority Streets, retail bays shall be no greater than 30 ft wide, though a single retailer may combine and occupy multiple bays.

**At-grade Activation for Ingerson Avenue and Harney Way Frontages** - The two blocks of Ingerson Avenue and Harney Way closest to their intersection shall be activated in accordance with Section 3.2 (Retail Streets). For the two blocks of Ingerson Avenue and Harney Way closest to Arelious Walker Drive, a minimum of 80% of ground-floor building frontage shall include Active Uses. The remaining frontage can be used to provide other uses, including, but not limited to exit doors, garage lobbies, and utility rooms/access required at frontage.

### 5.3.9 Accessibility to Private Streets, Paseos, Plazas; Private Open Space Standards

#### Standards

**Open Space Area Requirements** – At the developers’ option, residential open space requirements established in Section 4.3.2.F may be met through a combination of privately accessible open space and privately owned publicly accessible open space provided that the latter is open to the public at certificate of occupancy for the particular residential development. Any publicly accessible open space counted towards the requirement shall be (i) in addition to minimum public open space requirements established in this document, (ii) adjacent to the applicable residential building. Such privately owned publicly accessible open spaces may not be closed to residential users by private events, and such areas may not be double-counted to satisfy open space requirements for multiple residential buildings.



### 5.3.10 Parking and Service Entries

#### Intent

Large floor plate buildings permitted in Candlestick Center need to accommodate for loading and parking, while addressing the need for pedestrian oriented circulation of Candlestick Center.

#### Standards

**Entrances** – Parking and service vehicle entrances shall be permitted as follows along Private Streets in Candlestick Center, except along Retail Priority Streets (which are subject to Section 4 standards for parking and service vehicle entrances).

- Separate vehicular ingress or egress shall each be a maximum width of 14 ft.
- Any combined parking ingress and egress for off-street parking shall be a maximum width of 27 ft.
- All entrances must be spaced at a minimum of 60 ft apart.
- Sharing of parking entrances and loading is encouraged. Shared parking entrances shall be a minimum of 40 ft from block corners and 20 ft from building entrances.
- The width of any combined parking ingress and egress for off-street parking may be greater than 27 ft if a traffic impact analysis (TIA) substantiates the need for additional lane(s) for ingress or egress to reduce traffic impacts.
- For separate loading and service bays, entrance width shall be a maximum of 20 ft. If additional bays are necessary, the combined width of parking, loading and service bay entrances shall not exceed 20% of the block face.

### 5.3.11 Paseos

#### Intent

Pedestrian connections in the form of Paseos will connect internal blocks and prioritize pedestrian access throughout Candlestick Center. Paseos may be landscaped and lined with At-grade Activation. They are intended to allow public access through private development blocks and do not provide vehicular access except as required for emergency vehicle access (EVA).

#### Standards

**Paseo Locations** - The interior streets within Candlestick Center shall be connected to each other and exterior streets by at least three Paseos, as follows: (i) at least one Paseo shall connect two interior streets and be separated from the central plaza by at least one building and a distance of at least 100 feet. (ii) at least one Paseo shall connect Arelious Walker Drive and the adjacent interior street, and (iii) at least one Paseo shall connect Ingerson Avenue and the adjacent interior street along the northwestern



Precedent: Paseo between office buildings.  
Credits: Steam Mill Lane, ASPECT Studios,  
Photo © Simon London.

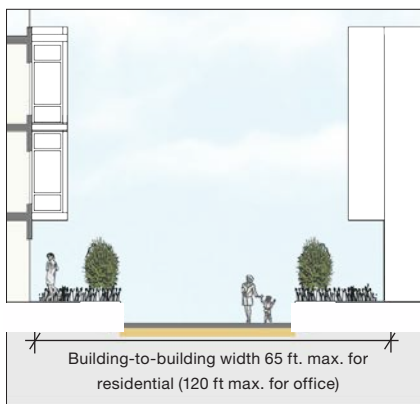

Conceptual Paseo section.



Precedent: Residential development fronting a Paseo.

500 feet of Ingerson Avenue. Alternative Paseo locations that promote pedestrian circulation requirements of Section 5.3.3 may be considered as deviations.

**Public Access** – Paseos shall be accessible to public at all times.

**Paseo Edges** –Paseos shall be designed with strong edges defined by neighboring buildings, bollards, striping, stairs, or similar features.

**Building Face-to face Dimensions** – Paseos bordering residential buildings shall be 40 ft to 65 ft wide (measured from face of building to face of building), including any setbacks and building projections. Paseos between two office buildings or office and residential buildings shall be 40 ft to 120 ft wide (measured from face of building to face of building), including any setbacks and building projections.

**Paseo Width** - Paseo widths should be divided into zones to provide for buffers (referred to in the D4D as setbacks) between the building front and the main circulation thoroughway such that the thoroughway is approximately 1/2 to 1/3 the width of the Paseo with the remaining 1/2 to 2/3 dedicated to the buffers on either side. Features in the buffer could include landscaping, stormwater treatment, porches, terraces, patios or other features that enhance social interaction and safety in the public realm.

**Activation** – For buildings facing a Paseo, 50% of Paseo frontage shall be Active Uses. The treatment of such Paseos shall prioritize pedestrian access and enable entry into the core of Candlestick Center. Upper floors of buildings are exempt from this requirement. Interior Active Uses such as workspaces and restaurant seating shall open out into the Paseos whenever feasible. Social spaces and seating are encouraged along Paseos to activate the space.

There shall be at least one entrance along any such Paseo frontage, with a minimum of 30% of transparent glazing for the entire ground floor frontage, and 60% transparent glazing for ground floor lobby and amenity space measured in the area between four and eight feet in height above grade.

**Landscaping** – A landscaped buffer zone with a minimum clear width of 5 ft (8 ft for residential units) shall be provided.

**Street Trees** – Landscaping along the Paseo shall include street trees (minimum of every 30 ft), at-grade landscape planters, patios and steps, benches, and pedestrian scale lighting.

**Lighting** – Adequate lighting shall be provided to ensure pedestrian safety while not being intrusive to adjacent residential units. Pedestrian scale lighting shall be included within the Paseo width.



Precedent: Example Enhanced Sidewalk amenities such as street trees, benches and bike racks.



Precedent: Example Enhanced Sidewalk with special paving and planter beds.



Precedent: Example of a promenade.  
Credits: Nicholson Street mall photo by Dianna Snape.

### 5.3.12 Enhanced Sidewalks

#### Intent

At key locations in Candlestick Center where pedestrian connectivity is especially important, Enhanced Sidewalks shall be provided. Two conceptual locations are shown in Figure 5.6.

#### Standards

**Location** – One Enhanced Sidewalk shall be provided within the publicly accessible right-of-way, identified as Jamestown Lane. This Enhanced Sidewalk shall continue the Jamestown Avenue alignment from Arellious Walker for at least one block into the site. These will be generously proportioned sidewalks with ample landscape and furnishings.

**Dimension** – The minimum dimension for Enhanced Sidewalks shall be 15 ft, with 10 ft pedestrian zone and 5 ft landscape and furnishings zone.

**Amenities** – The Enhanced Sidewalk shall include amenities in addition to typical sidewalks that facilitate pedestrian connectivity, including but not limited to attractive pedestrian scale lighting and paving, and all of which shall be compatible with neighboring plazas, sidewalks and Paseos.

### 5.3.13 Setback Building and/or Parking Facility; Public Promenade

#### Intent

This section provides a permissive exception to the Street Wall requirements that will allow the creation of a building and/or parking facility set back from the adjacent property line with linear public open space immediately adjacent to and as a forecourt to a building and/or parking facility set back from the property line. The public promenade will be a linear plaza that will act as the marker of an entry into Candlestick Center. It will be landscaped, with space for pedestrians to gather, relax and people-watch.

#### Standards

**Location** – At one location entirely within one block of either Ingerson Avenue or Harney Way, an exception to applicable build-to standards is permitted to allow a building/parking facility that is set back from the street, provided that the area created by the setback is activated with a public promenade meeting the standards of this Section.

#### Promenade Activation and Active Edge

- 70% of the ground-floor frontage facing the public street shall feature Active Uses. Structural elements are not included in the calculation of Active Uses. Storefronts shall either be fully open to the street or feature entries of no less than 50% of the use's linear frontage,



Figure 5.7 Active Edge

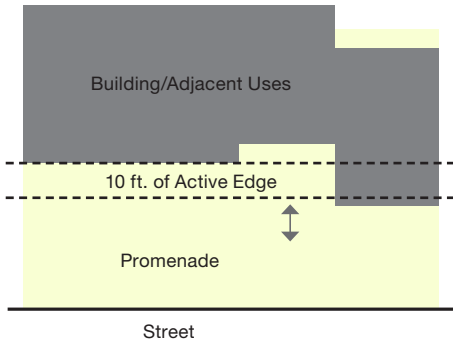

to enable the internal use to spill out into the promenade. Uses are preferred to be but not required to be retail, but are required have features that lend themselves to a mix of internal and external functions that activate public space.

- The first 10 feet of setback along the entire ground-floor frontage facing the public street shall be designated as the “promenade Active Edge,” which shall be continuously occupied, used and activated by its adjacent uses. Uses for the Active Edge are required to be provided only during regular business hours. Uses are not required to be retail but are required have features that lend themselves to a mix of internal and external functions that can activate public space.

**Promenade Character and Dimension** – The promenade will be a linear plaza providing a distinct space, defined with landscaping, built elements and amenities (described below), for passive recreation. The promenade shall occupy the entirety of the area created by the setback permitted above, and shall be no more than 45 ft wide (measured from the property line/right-of-way to Building Face).

**Continuation of Streetscape** – The edge of the promenade closest to public street shall continue the streetscape elements of the adjacent street. This shall include street trees, paving surfaces and furnishings.

**Built Elements** – Within the setback area the promenade shall provide patio spaces, entrances to abutting buildings, publicly accessible buildings, outdoor seating zones, bike and scooter parking areas and landscaping.

**Amenities** – The promenade shall provide the following amenities: moveable and built-in seating, attractive pedestrian scale lighting, and special paving treatment to coordinate with neighboring Enhanced Sidewalks and plazas.

### 5.3.14 Vista Terminations

**Intent**

Vista Terminations are the portion of a building façade terminating a view at the end of a Private Street or Paseo. These standards are intended to minimize or eliminate unsightly views down streets.

**Standards**

**Vista Termination Dimension** – The area covered by Vista Termination standards is the portion of the building façade terminating the view at the end of a Private Street or Paseo within Candlestick Center, being the product of the full height of the building and the dimensional width of the street or Paseo leading to the termination of the vista.



Precedent: Example of Vista Terminations.

**Prohibited Elements in Vista Terminations.** Buildings within a Vista Termination shall not include the following elements:

- Parking facility entries.
- Unscreened walls at parking facilities without enhanced screening of the applicable facade.
- Blank walls.
- Large mechanical equipment installations without screening.
- Building walls without articulation.
- Utility rooms, meters and connections.

### 5.3.15 Skyway Connection

#### Intent

Skyway Connection are upper level bridges between buildings which are primarily for pedestrians uses. They allow flexibility in commercial office buildings to combine floor plates together to accommodate larger business operations while meeting bulk controls. They may be enclosed or open to the elements.

#### Standards

**Number of Skyways** - One Skyway Connection shall be permitted within Candlestick Center.

**Building Type** - The Skyway Connection shall be permitted only between office buildings.

**Location** - The Skyway Connection shall be permitted above Paseos between office buildings.







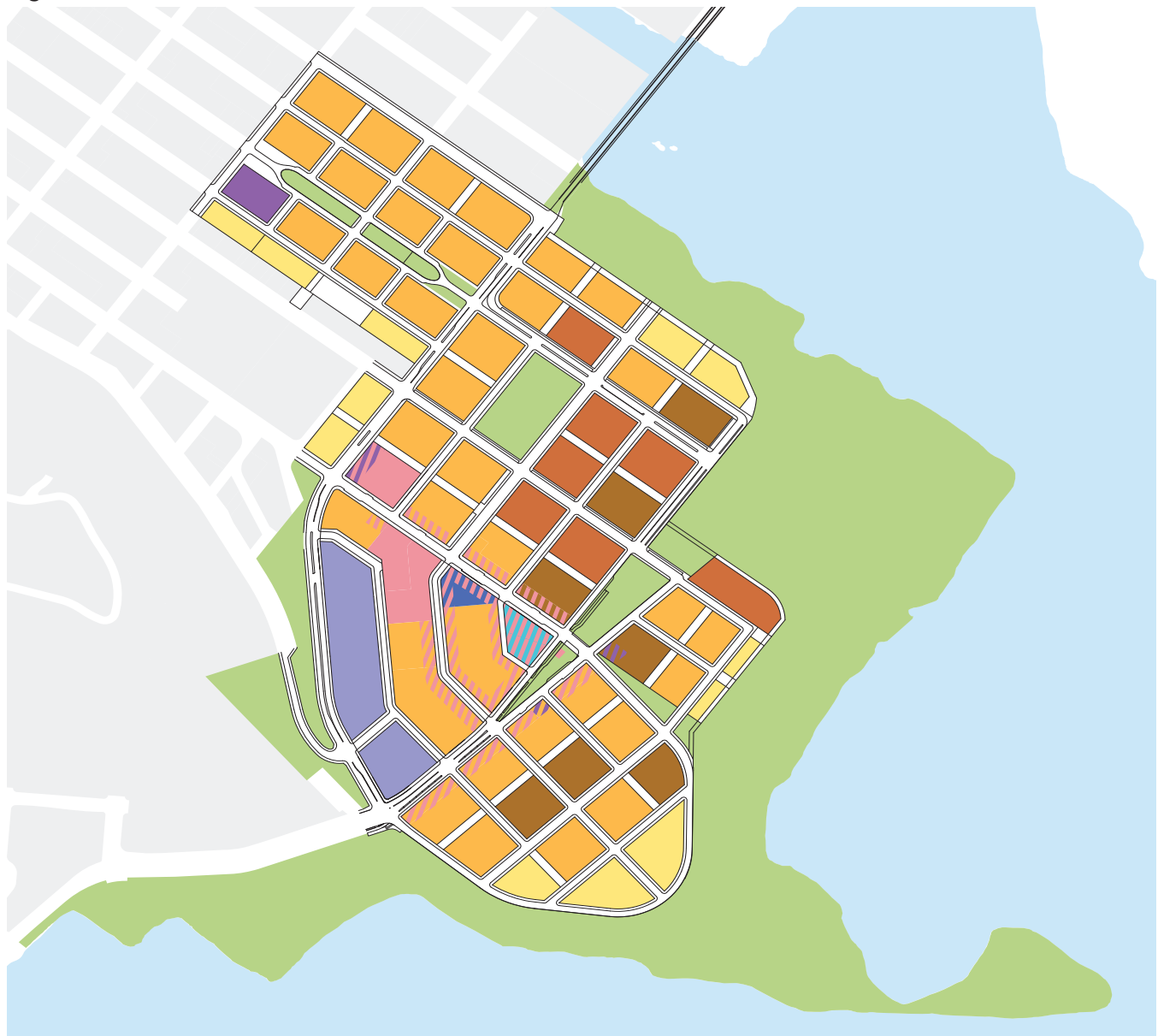



**Dimension** - The Skyway Connection shall be no wider than 12 ft and no taller than one story in height. It shall provide a minimum of 30 ft vertical clearance below.

**Transparency** - The Skyway Connection shall be fenestrated with transparent windows or openings with a minimum of 70% transparent openings on the sides. Glass shall be no more than 10% reflective, with 80% light transmittance, and without tint or coloration.

Figure 5.8 Illustrative Land Use Plan of Candlestick Center



LAND USE

- |   |  |
|---|--|
|  Residential Density I<br>(15-75 Units Per Acre)     |  Community Use            |
|  Residential Density II<br>(50-125 Units Per Acre)   |  Parks and Open Space     |
|  Residential Density III<br>(100-175 Units Per Acre) |  Retail                   |
|  Residential Density IV<br>(175-285 Units Per Acre)  |  Hotel                    |
|   |  Signature Building       |
|   |  Commercial (Office, R&D) |
|   |  Existing Use to Remain   |



N  
  
 0'  750'  
 Scale: 1" = 750'  
 MAP GENERATED JULY 22, 2019



Figure 5.9 Candlestick Center Context



Illustrative rendering of Candlestick Point with Candlestick Center in the foreground.

## 5.4 Candlestick South

---











Precedent – Articulated streetwall.



Precedent – Homes on the park.



Precedent – High-rise with bustle.



Precedent – Edge fronting CPSRA.

### 5.4.1 Candlestick South – General Description

Candlestick South derives its character from both the Harney Way retail street and the activity of the beach and surrounding Candlestick Point State Recreation Area (CPSRA). A mix of low-rise and high-rise buildings are complemented by a fine grained streets and lanes system that links residents to the Mini-wedge Community Park, Bayview Gardens Wedge Destination Park, and the surrounding CPSRA.

**Land Use / Built Form** – Mixed-use buildings define the southern half of Harney Way creating a vibrant retail street. The bulk of the neighborhood is comprised of low-rise flats and townhomes. Both wedge parks are framed with strong street walls to help define the spaces, while townhomes or flats border the CPSRA. Up to five high-rise towers punctuate the neighborhood with extraordinary views to the Bay, while serving as visual landmarks. The high-rise towers have been strategically located to bring the bulk of residential density to the heart of Candlestick, in close proximity to shopping, services, and public transit. Towers are predominantly stepped back from the CPSRA emphasizing a less formal park experience. Further, the proposed towers located south of the Mini-wedge Community Park shall be situated in a manner that preserves a view corridor from the top of Bayview Hill to Candlestick Point.

**Open Space** – The Mini-wedge Community Park forms the heart of the community and complements the larger Bayview Gardens Wedge Park within Candlestick North. The Mini-wedge is oriented to focus views to the CPSRA beach and the point of land that gives Candlestick its name. The community’s eastern and southern edges are wrapped by the CPSRA, creating views to the bay and easy access to recreation.

**Streets** – A defining element of this community is its mixed-use main street, Harney Way. This primary commercial street for this community will be a retail boulevard with dedicated bus rapid transit (BRT) lanes in each direction and a vehicle travel lane in each direction. Other streets in the community are local serving, and mid-block breaks offer greater connectivity to the parks and water’s edge. A laneway is included parallel to Harney Way to serve commercial uses.

Figure 5.10 Candlestick South Illustrative Site Plan



**Legend**

- Low-rise Residential
- High-rise Tower
- Mixed-use

- ① Mini-wedge Community Park
- ② CPSRA Beach
- ③ Bayview Gardens/Wedge Destination Park
- ④ Candlestick Point State Recreation Area
- ⑤ Candlestick Center Neighborhood
- ⑥ Candlestick North Neighborhood
- ⑦ BRT/Transit Stop and Plaza





Community gardens.



CPSRA - Great lawn.



CPSRA - Wind surfing beach.





View of Candlestick South looking west.

*Note: Towers shown are one example of allowable tower locations (see Section 4.2.2 for details)*

## 5.4.2 Candlestick South Urban Design

Refer to Figure 5.9 for the location of the following standards and guidelines.

A block plan indicating dimensions and parcel areas is included in Appendix B.

### Standards

#### S1. Mixed-use Zone / Required Ground Floor Commercial

- Harney Way, between Arelious Walker Drive and Ingerson Avenue shall be a mixed-use zone along its frontage within the neighborhood
- Ground floor use shall be commercial along the aforementioned streets with a minimum floor-to-floor height of 12 ft.

#### S2. Street Wall Heights

- Minimum height 35 ft – A mixed-use street wall to a minimum of 35 ft shall be built along Harney Way between Arelious Walker Drive and Ingerson Avenue.
- Minimum height 40 ft – A street wall to a minimum of 40 ft shall be built along Harney Way between Ingerson Avenue and Gilman Avenue, and on both sides of the Mini-wedge Community Park.

#### S3. Towers

- Towers shall be located within the tower zones described in the Heights Section 4.2.2. If moved from the preferred location, towers shall be sited fronting major streets and/or frame parks and important public places, and shall require a shadow and wind analysis as per Section 4.2.6 and Section 4.2.5 respectively.
- No more than 5 towers shall be located within Candlestick South neighborhood. The towers on blocks 1 and 4a, if developed, shall not be relocated from the position shown. All other towers may be relocated within the tower zone. The view corridor indicated in 5.2.1 must be maintained.

#### S4. Mid-block Breaks

- Shall be provided within the blocks indicated on Figure 5.9. Actual locations may vary slightly from that shown; however, all blocks indicated must contain a mid-block break.

#### S5. CPSRA Edge

- A publicly accessible walkway/emergency access shall be provided as shown in Figure 5.9.

---

## Guidelines

### **G1. Encouraged Ground Floor Commercial**

- Additional ground floor commercial is encouraged along the Bayview Gardens Wedge Destination Park and Mini-wedge Community Park.
- Encouraged use is neighborhood-serving retail.
- Retail uses when provided are encouraged to be located at street corners, particularly the corner of Ingerson Avenue and Harney Way.

### **G2. Important Intersections**

- The corners of Arelious Walker Drive and Harney Way, and Harney Way and Ingerson Avenue are important intersections, serving as either gateways into the site or zones of high pedestrian activity. Architectural elements should be utilized to accentuate and differentiate these intersections.

### **G3. Height Variation**

- For buildings along Harvey Way, building heights are encouraged to be varied to add architectural interest to the streetscape.



Figure 5.11 Candlestick South Urban Design

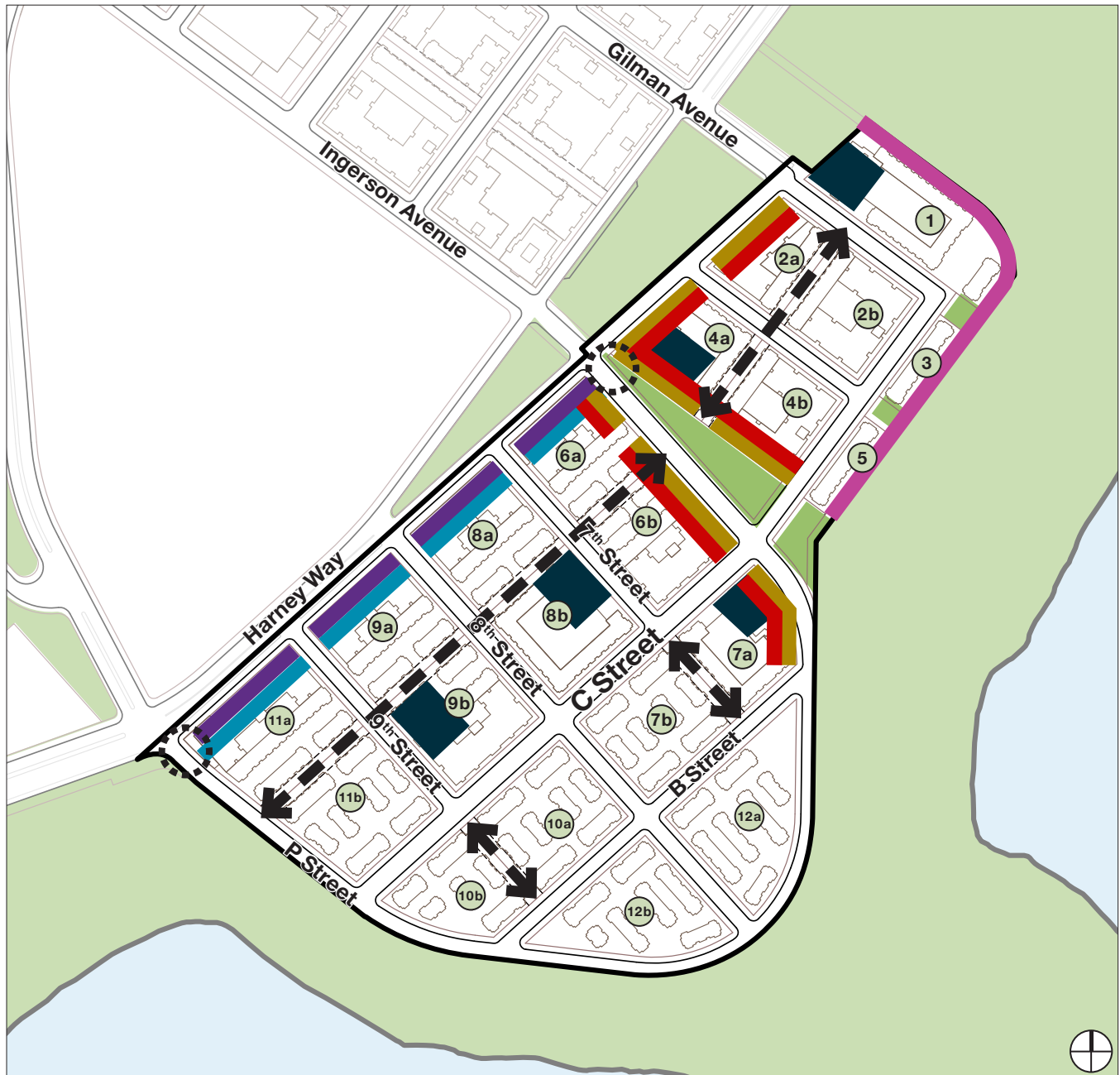

Legend

- S1 – Required Ground Floor Commercial
- S2 / G3 – Mixed-use Street Wall – 35 ft Minimum Height
- S2 – Residential Street Wall – 40 ft Minimum Height
- S3 – Encouraged Tower Locations (refer to Section 4.2.2 for the location of allowable tower zones)
- S4 / G3 – Mid-block Breaks (Pedestrian Mews or Vehicular Laneway)
- S5 – State Park Edge
- Park
- G1 – Encouraged Ground Floor Commercial
- G2 – Important Intersections
- # Block Numbers

**PAGE LEFT INTENTIONALLY BLANK**

# 6

---





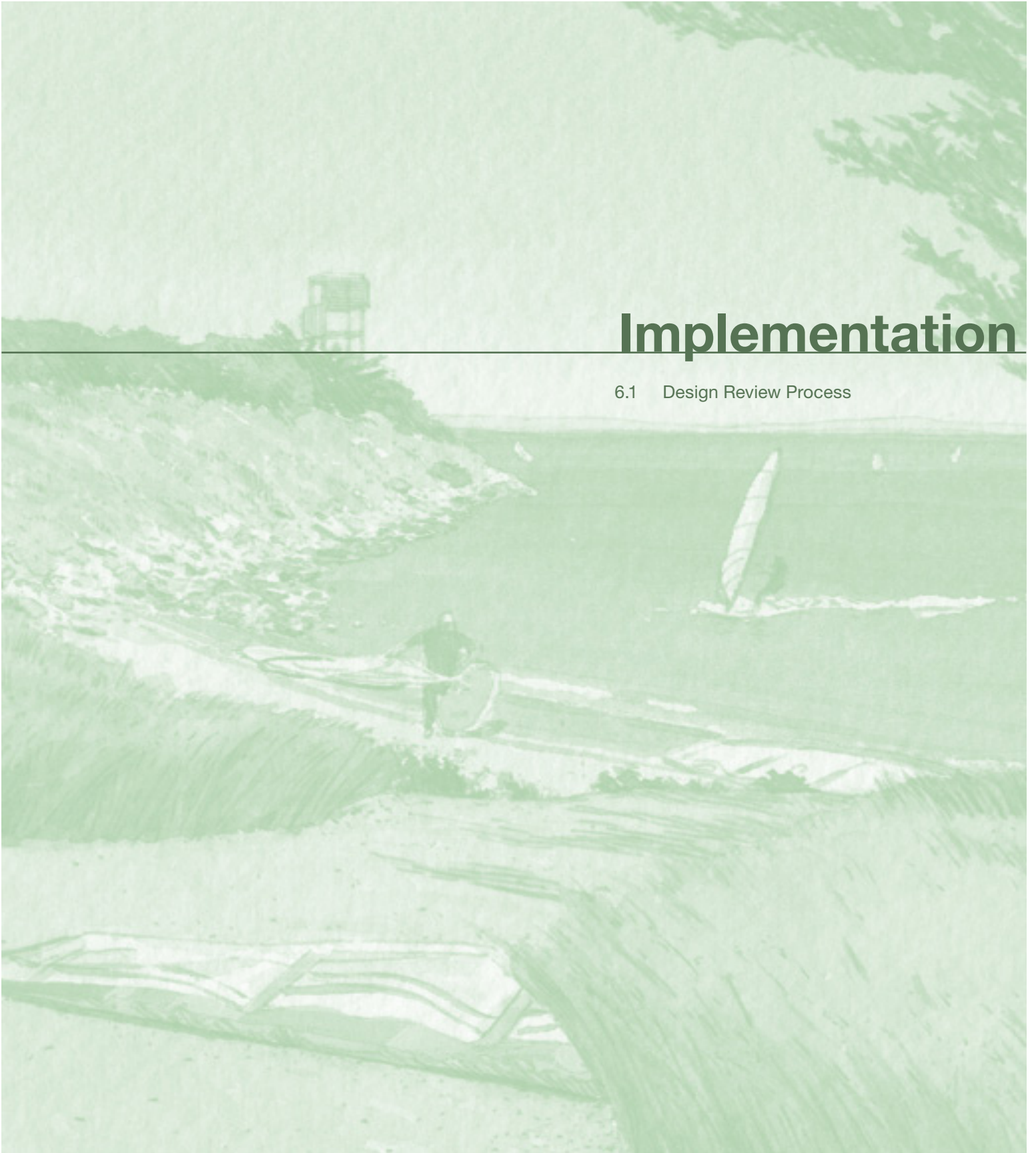

# Implementation

## 6.1 Design Review Process

## 6 Implementation

---

### 6.1 Design Review Process

#### Implementation

Implementation of this D4D shall be in accordance with the BVHP Plan as well as any disposition and development agreement or owner participation agreement entered into by the Redevelopment Agency of the City and County of San Francisco, as more fully described below.

#### Bayview Hunters Point Redevelopment Plan

Candlestick lies within Zone 1 of the Bayview Hunters Point Redevelopment Project Area. This D4D provides the detailed design standards and guidelines for development within Zone 1 of this Redevelopment Project Area.

#### Review and Approval of Design Documents

Any disposition and development agreement pertaining to Candlestick (Zone 1) shall abide by the Design Review and Document Approval Procedure (DRDAP). The DRDAP shall establish the processes by which applications for various Agency approvals required under a disposition and development agreement or owner participation agreement are to be submitted and reviewed by the Agency and other City agencies as well as the standards by which such approvals are to be granted by the Agency. The DRDAP shall further establish the processes and timelines for Agency review of architectural and design documents – such as schematic design documents, design development documents, and construction documents – for various improvements within the area subject to the disposition and development agreement or owner participation agreement.

In addition, it is anticipated that the Agency and City agencies having jurisdiction over the development contemplated by this Design for Development will enter into one or more Interagency Cooperation Agreements that will set forth the City agencies' obligations in connection with review and approval of applications pursuant to the DRDAP as well as review and approval of various permits, subdivision maps, and other authorizations required from the City.

As provided in the BVHP Plan, Agency review of any application relating to development within Candlestick shall be evaluated for consistency with the standards set forth in the Redevelopment Plan and the standards set forth in this D4D and shall follow the process set forth in the applicable DRDAP.

## Variances and Deviations

The owner of any property that is subject to this Design for Development document may make a written request for either a deviation or a variance from the design standards, design guidelines, or any other provision within this D4D or the BVHP Plan pursuant to Section VII of the BVHP Plan, or for deviation, pursuant to the text below.

### Deviations

A deviation is a minor modification no greater than 10% of a dimensional or numerical building standard. Building Height and bulk/massing standards are not subject to modification by deviation.

Deviations must meet the purpose and intent statements of the Design for Development and may be authorized by the OCII Director. To the extent reasonably possible, proposed Deviations must be identified at the time of Schematic Design Document submittal pursuant to the DRDAP. The OCII Director's approval or disapproval of proposed Deviations shall be limited to a determination of its compliance with the Design for Development, the Redevelopment Plan and any applicable Redevelopment Requirements. Should a request for Deviation be made after OCII Commission approval of Schematic Design, the OCII Director, in her or his sole discretion, may seek comment and guidance from the public and OCII Commission on the granting of any deviations.

### Variances

Requests for a variance shall state fully the grounds of the application and the facts pertaining thereto. The Agency Commission may grant a variance from the development controls of this D4D or the BVHP Plan under the following circumstances:

- Due to unique physical constraints or other extraordinary circumstances applicable to the property, the enforcement of development regulations without a variance would otherwise result in practical difficulties for development and create undue hardship for the property owner or developer or constitute an unreasonable limitation beyond the intent of the BVHP Plan; and
- The granting of a variance would be in harmony with the goals of the BVHP Plan and would not be materially detrimental to the public welfare or materially injurious to neighboring property or improvements in the vicinity.

The Agency's determination to grant or deny a variance will be final and will not be appealable to the Planning Department.

### Process for Amendment

Amendments to this D4D shall be approved by both the San Francisco Planning Commission and the Agency Commission.



# 7





# Appendix

- 7.1 Appendix A – Term Definitions
- 7.2 Appendix B – Block Plans
- 7.3 Appendix C – Additional Studies

# 7 Appendix

## 7.1 Appendix A – Term Definitions

<b>Active Use</b>	Ground floor land uses that create an interesting and inviting pedestrian environment that enhances neighborhood vibrancy and safety. Active Uses may include, but not be limited to, (i) retail (including maker space), and restaurant uses, (ii) bike workshops (excluding storage), and (iii) office, residential or entertainment use lobbies, atria, residential, hospitality or office building lounges or amenity spaces, pet areas, sales/ leasing offices, management offices, all meeting transparency requirements of Section 5.3.8.
<b>Activating Features</b>	Activating features may include, but not be limited to features, such as green walls, trellises, murals, art installations, metal or wood panels, cast-in-place or precast concrete panels, clear, colored, or translucent glass with reflectivity up to 50%, or other special architectural treatments.
<b>Agency</b>	The Office of Community Investment and Infrastructure (OCII), or Successor Agency to the San Francisco Redevelopment Agency.
<b>Apparent Face</b>	The unbroken plane of a building without any change- either in the form of offset in horizontal plane or a change in fenestration or material.
<b>At-grade Activation</b>	Ground floor uses and features provided to create an inviting pedestrian environment and to improve neighborhood safety along public and Private Street, Paseos, and plazas.
<b>Block</b>	An area of land bounded by public lands, including streets or parks.
<b>Building</b>	Any structure having a roof supported by columns or walls.
<b>Building Entry</b>	Any point of a building associated with the accessibility of the user, not including service or loading access.
<b>Building Face</b>	The major or primary plane of the exterior wall of the building. The term is often used in context with its relationship to an adjacent street or public area.
<b>Building Height</b>	The vertical distance between finished grade and the top of a building. The building top is defined as the top of the finished roof in the case of a flat roof, and the average height of the rise in the case of a pitched or stepped roof.
<b>Building Projection</b>	A portion of the building that extends beyond the primary building face, either into a setback or beyond the property line.
<b>Build-to Line</b>	The primary building face, of which a certain percentage of the building must be built to. Location is aligned with the setback line.
<b>Bulk</b>	The maximum physical dimensions of built volume. Standards include maximum plan dimension and maximum floor plate size.



<b>Blank Walls</b>	The area of building facade, parallel to the property line, which does not include an opening, entrance, or building articulation.
<b>Class I Bicycle Parking Space(s)</b>	Spaces in secure, weather-protected facilities intended for use as long-term, overnight, and work-day bicycle storage by dwelling unit residents, non-residential occupants, and Employees. Intended for use as long-term, overnight, and work-day bicycle storage by dwelling unit residents, non-residential occupants, and Employees.
<b>Class II Bicycle Parking Space(s)</b>	Bicycle racks located in a publicly-accessible, highly visible location intended for transient or short-term use by visitors, guests, and patrons to the building or use.
<b>Court</b>	Any space on a lot other than a yard which, from a point not more than two ft above the floor line of the lowest story in the building on the lot in which there are windows from rooms abutting and served by the court, is open and unobstructed to the sky, except for obstructions permitted by the San Francisco Planning Code. An "outer court" is a court, one entire side or end of which is bounded by a front setback, a rear yard, a side yard, a front lot line, a street, or an alley. An "inner court" is any court which is not an outer court.
<b>Dwelling Unit</b>	A residential use that consists of a suite of one or more rooms and includes sleeping, bathing, cooking, and eating facilities.
<b>Enhanced Sidewalk</b>	Generously proportioned paved pathway or sidewalk provided on the side of a street containing high quality streetscape amenities, that comply with Standards within Section 5.3.12.
<b>Façade</b>	Any vertical exterior face or wall of a building that is adjacent to or fronts on a street, public or semi-private right-of-way, park, or plaza.
<b>Facade Articulation</b>	Application of visually interesting materials, textures, and colors to a building façade, including use of strategies such as vertical or horizontal recesses, shading devices, screening devices, and openings to create variation in building facade.
<b>Floor Area, Gross</b>	The sum of the gross areas of the several floors of a building or buildings, measured from the exterior faces of exterior walls or from the centerlines of walls separating two buildings. Where columns are outside and separated from an exterior wall (curtain wall) which encloses the building space or are otherwise so arranged that the curtain wall is clearly separate from the structural members, the exterior face of the curtain wall shall be the line of measurement, and the area of the columns themselves at each floor shall also be counted.
<b>Floor Area Ratio</b>	The ratio of the gross floor area of all the buildings on a lot to the area of the lot. In cases in which portions of the gross floor area of a building project horizontally beyond the lot lines, all such projecting gross floor area shall also be included in determining the floor area ratio.

---

<b>Floor, Ground</b>	The lowest story of a building, other than a basement or cellar as defined in the Building Code.
<b>Focal Point</b>	An area within the public realm that is at a major intersection or within the park system, which will have a high degree of pedestrian use due to the immediately adjacent uses.
<b>Gateway</b>	A primary vehicular or pedestrian point of entry into the development project, typically at a key intersection between two or more public streets.
<b>Ground Floor Retail Required</b>	The percentage of building frontage facing the street that requires ground floor space suitable for retail use.
<b>Guideline</b>	Design recommendations for both private and public design and construction activities within the development project.
<b>Live / Work Unit</b>	A structure or portion of a structure combining a residential living space for a household or group of persons with an integrated work space principally used by one or more of the residents of that unit. Work spaces uses in a Live/Work Unit must comply with the other non-residential uses allowed within the respective land use District.
<b>Maximum Plan Dimension</b>	The maximum linear frontage dimension at pedestrian level.
<b>Mid-block Break</b>	A pedestrian pathway that provides a mid-block connection - either between parallel street frontages or between street frontages and rear parking areas. Mid-block breaks are landscaped and may also include front doors to residential or retail uses. They are intended for public pedestrian use and provided through public easements over private land.
<b>Modulation</b>	Major variation in the massing, height, or setback of a building (as a means of reducing the structure's perceived bulk)
<b>Neighborhood Retail</b>	A commercial use that provides goods and/or services directly to the customer, whose primary clientele is customers who live or work nearby and who can access the establishment directly from the street in a walk-in basis. This use may provide goods and/or services to the business community, provided that it also serves the general public. This use would include those that sell, for example, groceries, personal toiletries, magazines, smaller scale comparison shopping; personal services such as laundromats, health clubs, formula retail outlets, hair or nail salons; and uses designed to attract customers from the surrounding neighborhood. Retail uses can also include outdoor activity areas, open air sales areas, and walk-up facilities (such as ATMs or window service) related to the retail sale or service use and need not be granted separate approvals for such features.
<b>Paseo</b>	Pedestrian pathway that is accessible to the public, connects private development blocks and prioritizes pedestrian access within the block between buildings. Paseos include a clear pedestrian walking zone and buffer zones including streetscape amenities and landscaping.

---

<b>Private Street</b>	Internal streets within a private development block that connect with public street network to provide vehicular, bicycle and pedestrian access.
<b>Property Line</b>	The boundary line between two pieces of property.
<b>Regional Retail</b>	A commercial use that provides goods and/or services directly to the customer, whose primary clientele is customers who live throughout the surrounding region and may include both small and large format tenants up to 120,000 square feet. This use would include those who sell apparel, electronics, furniture, durable goods, specialty items, formula retail outlets, and other more expensive, and less frequently purchased items; beyond the surrounding neighborhood. Regional Retail sales and services can include counter and other walk-up facilities as well as adjacent outdoor activity areas accessory to such uses.
<b>Retail Priority Street</b>	A street located within the interior of Candlestick Center where ground floor building frontage must contain at least 50% retail use.
<b>Shared Private Street</b>	A curbsless street provided along a private right-of-way within Candlestick Center to prioritize pedestrians and emergency vehicle access. A Shared Private Street can be provided in areas where pedestrian activity is high and vehicular access needs to be discouraged. Such streets may have a single level of paving from building edge to building edge. The surface may include textured or permeable paving.
<b>Significant Break</b>	A vertical offset in the building facade from the primary façade applied to regulate the length of the apparent face.
<b>Setback</b>	A required distance that the Building Face shall be built in relation to the property line. Buildings with a setback of zero ft are built at the property line.
<b>Setback, Landscaping</b>	The portion of the required setback area that shall be and remain unpaved and devoted to plant material, including the use of native/ drought resistant plant material.
<b>Setback, Required</b>	The minimum required distance between a building or a structure and the adjacent public right-of-way line; or any adjacent private vehicle access way easement, excluding private driveways; or any interior property line. A required distance that the Building Face shall be built in relation to the property line. Buildings with a setback of zero ft are built at the property line.
<b>Standard</b>	The specific rules or measures establishing a level of quality or quantity, or a condition that must be complied with or satisfied
<b>Stepback</b>	The distance that upper levels of a building may be set back from the primary building face.



---

<b>Street</b>	A right-of-way, 30 ft or more in width, permanently dedicated to common and general use by the public, including any avenue, drive, boulevard, or similar way, but not including any freeway or highway without a general right of access for abutting properties.
<b>Street Property Line</b>	The boundary line between a street and an abutting property.
<b>Street Wall</b>	A continuous façade of buildings generally built along the property line facing a street or open space.
<b>Skyway Connections</b>	Skyway connections are upper level bridges between buildings which are primarily for pedestrian use.
<b>Tower Bustle</b>	A portion of a tower that extends horizontally past the main vertical form of the building. Generally confined to the lower four to six floors of the tower.
<b>Units Massing</b>	The overall exterior shape of a building or structure; the proportion aspect of the elements of the form.
<b>Use</b>	The purpose for which land or a structure, or both, are designed, constructed, arranged or intended, or for which they are occupied or maintained, let or leased.
<b>Wall</b>	Any streetwall area that is not transparent, including solid doors and mechanical area wall(s).
<b>Wrapping</b>	Any above-grade uses on the perimeter of parking facilities that are uses other than parking.
<b>Vehicular Laneway</b>	A vehicular access way located on a private parcel, but having a public easement over it.
<b>Vista Terminations</b>	The portion of a building façade terminating a view at the end of a Private Street or Paseo within Candlestick Center, being the product of the full height of building and width of the street or Paseo.



## 7.2 Appendix B – Block Plans

Block plans for the four neighborhoods are provided as reference. They indicate the block and street dimensions.

### 7.2.1 Alice Griffith – Block Plan

Block dimensions are shown in Figure 7.1 for all development blocks within the Alice Griffith neighborhood.

The chart below indicates the area of each development block in the neighborhood. Final dimension and areas will be defined by the sub-division mapping process.

Table 7.1 Alice Griffith Block Areas

ALICE GRIFFITH BLOCK AREAS	
BLOCK NUMBER	AREA (acres)
1	1.45
2	1.23
4	1.23
5	0.81
6	0.80
7	0.82
8	0.72
9	1.02
11	1.03
12	1.14
13	1.13
14	0.79
15	0.75
16	1.11
17	1.12
18	1.31
19	1.35
20	1.22
<b>TOTAL*</b>	<b>19.02</b>





\* Total does not include open spaces and streets.

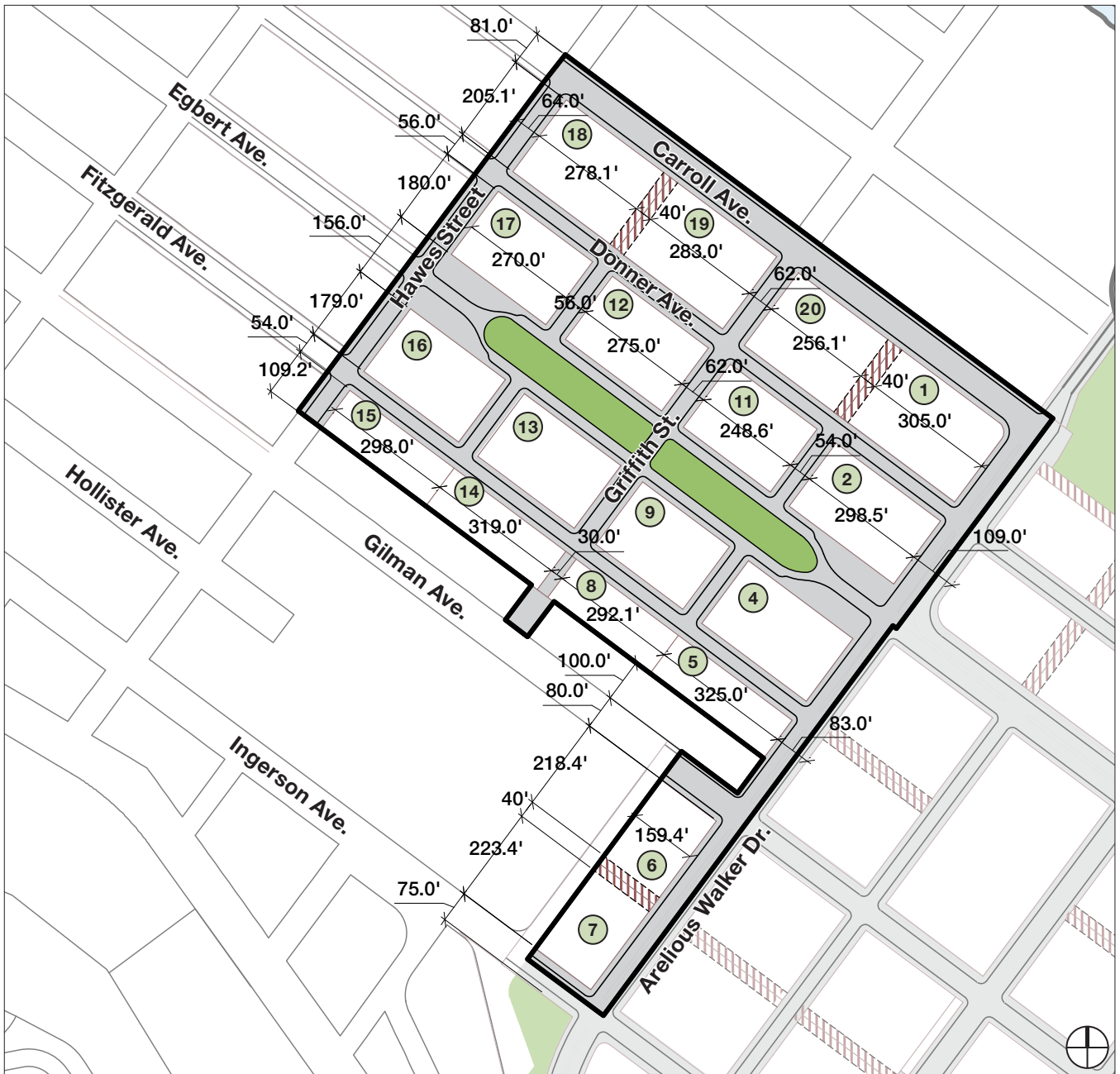

Figure 7.1 Alice Griffith Block Plan



Legend

-  Parks
-  Neighborhood Boundary
-  Development Block
-  Street – Public Right of Way  
(Pedestrian connection between along Griffith St. between Fitzgerald Ave. and Gilman Ave.)
-  Public Easement – Mid-block Breaks

## 7.2.2 Candlestick North – Block Plan

Block dimensions are shown in Figure 7.2 for all development blocks within the Candlestick North neighborhood. Certain corners are rounded to accommodate bus and fire truck turning radii (see Section 4.1.1).

The chart below indicates the area of each development block in the neighborhood. Final dimension and areas will be defined in the sub-division mapping process.

Table 7.2 Candlestick North Block Areas

CANDLESTICK NORTH BLOCK AREAS	
BLOCK NUMBER	AREA (acres)
1a	1.45
1b	1.45
2a	1.31
2b	1.31
3a	1.40
3b	1.50
4a	1.14
4b	1.16
5a	1.00
5b	1.00
6a	1.00
6b	0.96
7a	1.16
7b	1.28
8a	1.27
8b	1.36
9a	1.42
9b	1.52
10a	1.31
10b	1.31
11a	1.46
11b	1.46
12	3.12
<b>TOTAL*</b>	<b>31.35</b>

\* Total does not include open spaces and streets

Figure 7.2 Candlestick North Block Plan



Legend

- Parks
- Neighborhood Boundary
- # Development Block
- Street – Public Right of Way
- Public Easement – Mid-block Break



### 7.2.3 Candlestick Center – Block Plan

Block dimensions are shown in Figure 7.3 for the Candlestick Center neighborhood development block. Certain corners are rounded to accommodate bus and fire truck turning radii.

The chart below indicates the area of the development block in the neighborhood. Final dimension and areas will be defined in the sub-division mapping process.

Table 7.3 Candlestick Center Block Areas

CANDLESTICK CENTER BLOCK AREAS	
BLOCK NUMBER	AREA (acres)
1	22.29
<b>Total *</b>	<b>22.29</b>

\* Total does not include open spaces and streets

Figure 7.3 Candlestick Center Block Plan



Legend

- Parks/Plaza
- Neighborhood Boundary
- 1 Development Block
- Street – Public Right of Way
- Public Easement – Mid-block Break

### 7.2.4 Candlestick South – Block Plan

Parcel dimensions are included shown in Figure 7.4 for all development blocks within the Candlestick South Neighborhood. Certain corners are rounded to accommodate bus and fire truck turning radii (see Section 4.1.1).

The chart below indicates the area of each development block in the neighborhood. Final dimension and areas will be defined in the sub-division mapping process.

Table 7.4 Candlestick South Block Areas

CANDLESTICK SOUTH BLOCK AREAS	
BLOCK NUMBER	AREA (acres)
1	1.70
2a	0.77
2b	1.03
3	0.31
4a	1.05
4b	1.03
5	0.31
6a	1.15
6b	1.15
7a	1.08
7b	1.25
8a	1.21
8b	1.21
9a	1.25
9b	1.26
10a	1.30
10b	0.94
11a	1.53
11b	1.32
12a	1.62
12b	1.44
<b>TOTAL*</b>	<b>23.90</b>

\* Total does not include open spaces and streets



Figure 7.4 Candlestick South Block Plan



Legend

- Park
- Neighborhood Boundary
- Development Block
- Street - Public Right of Way
- Public Easement - Mid-block Break

## 7.3 Appendix C – Additional Studies

A number of additional studies have been developed for a variety of parcels. These may help to inform design decisions, regarding the Standards and Guidelines set forth in this document. These studies were undertaken prior to the formulation of the D4D and may not conform to current block configurations and/or al Standards and Guidelines.

### 7.3.1 Alice Griffith – Additional Studies

A representative block study for a block containing predominantly low-rise flats has been included for reference. In this study, a mixture of townhomes and flats wraps an internal garage. An internal courtyard is located on the parking rooftop. The parking garage is shown at grade, but could be built underground in order to create a stoop condition for at-grade units.

**Legend**

- ① Park Street
- ② Local Street
- ③ Townhomes
- ④ Low-rise Flats
- ⑤ Parking Rooftop Landscaping

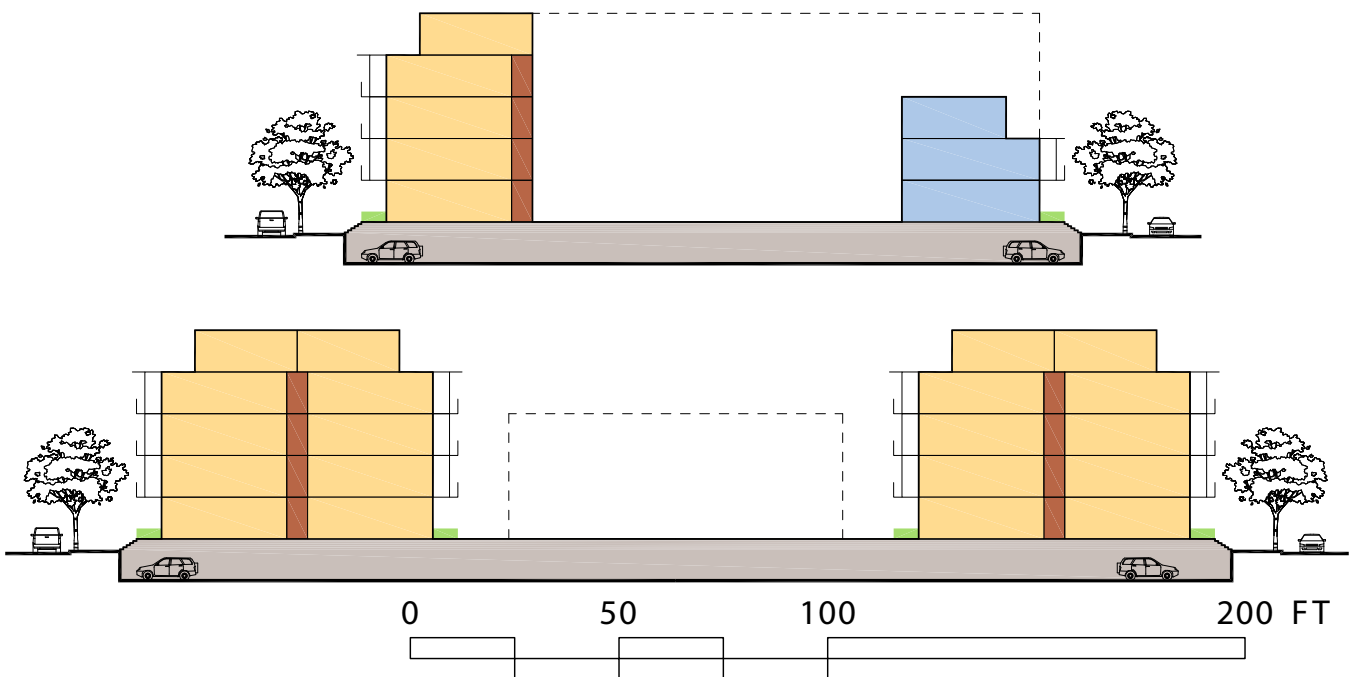
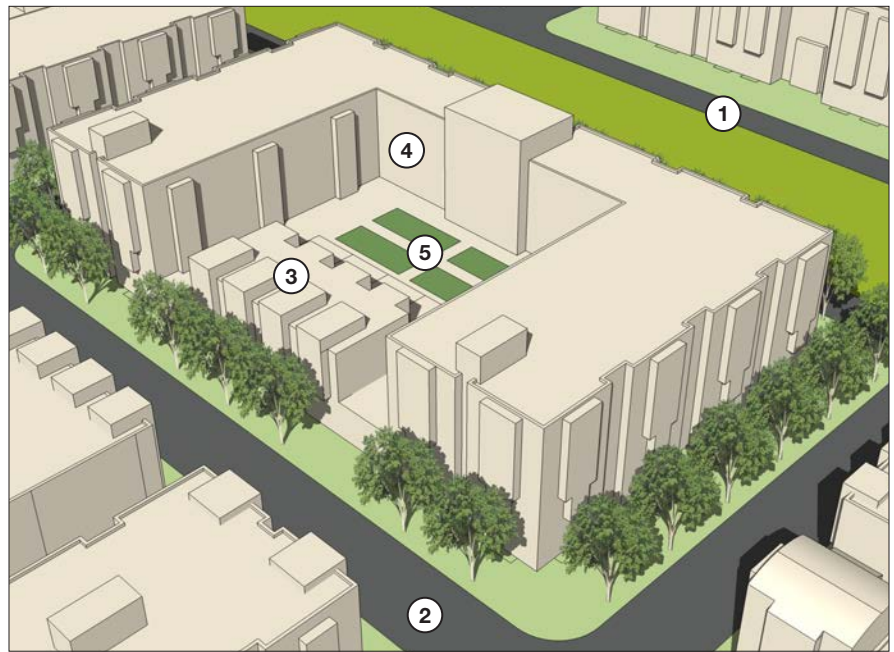



### 7.3.2 Candlestick North – Additional Studies

A representative block study for a mixed-use block containing low-rise flats and townhomes, as well as mid-rise and high-rise flats has been included for reference. In this study, mainly low-rise flats are located over retail. Townhomes front the pedestrian mews in order to create a human scale. Above grade parking is screened by at-grade retail or residential uses. A high-rise tower anchors one corner of the retail street, with the main tower mass meeting the street. A mid-rise bustle extends from the tower, framing an important park.



**Legend**

- ① Retail Street
- ② Local Street
- ③ Pedestrian Mews
- ④ Townhomes along Mews
- ⑤ Flats over Retail
- ⑥ Low-rise Flats
- ⑦ Mid-rise bustle frames Wedge Park
- ⑧ High-rise tower anchors corner.

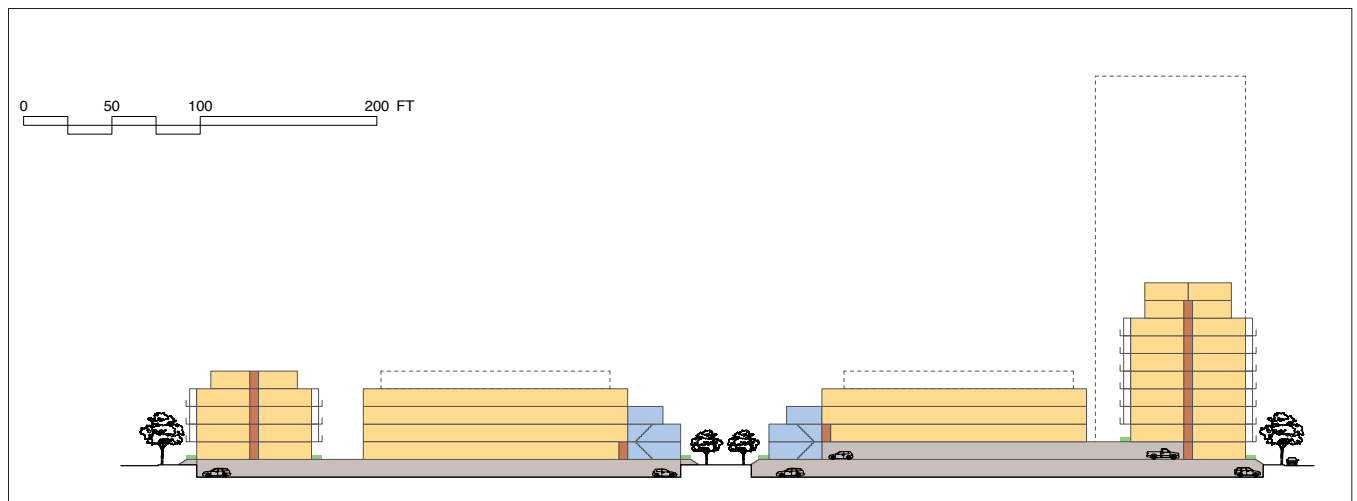

### 7.3.3 Candlestick South – Additional Studies

A representative block study for a mixed-use block containing low-rise and high-rise flats, and retail has been included for reference. In this study, low-rise flats are located above retail along the main street. A laneway separates the two portions of the block, serving as loading access for retail, as well as parking access. A high-rise tower and accompanying low-rise flats wrap a parking structure, with private open space located above the parking rooftop.

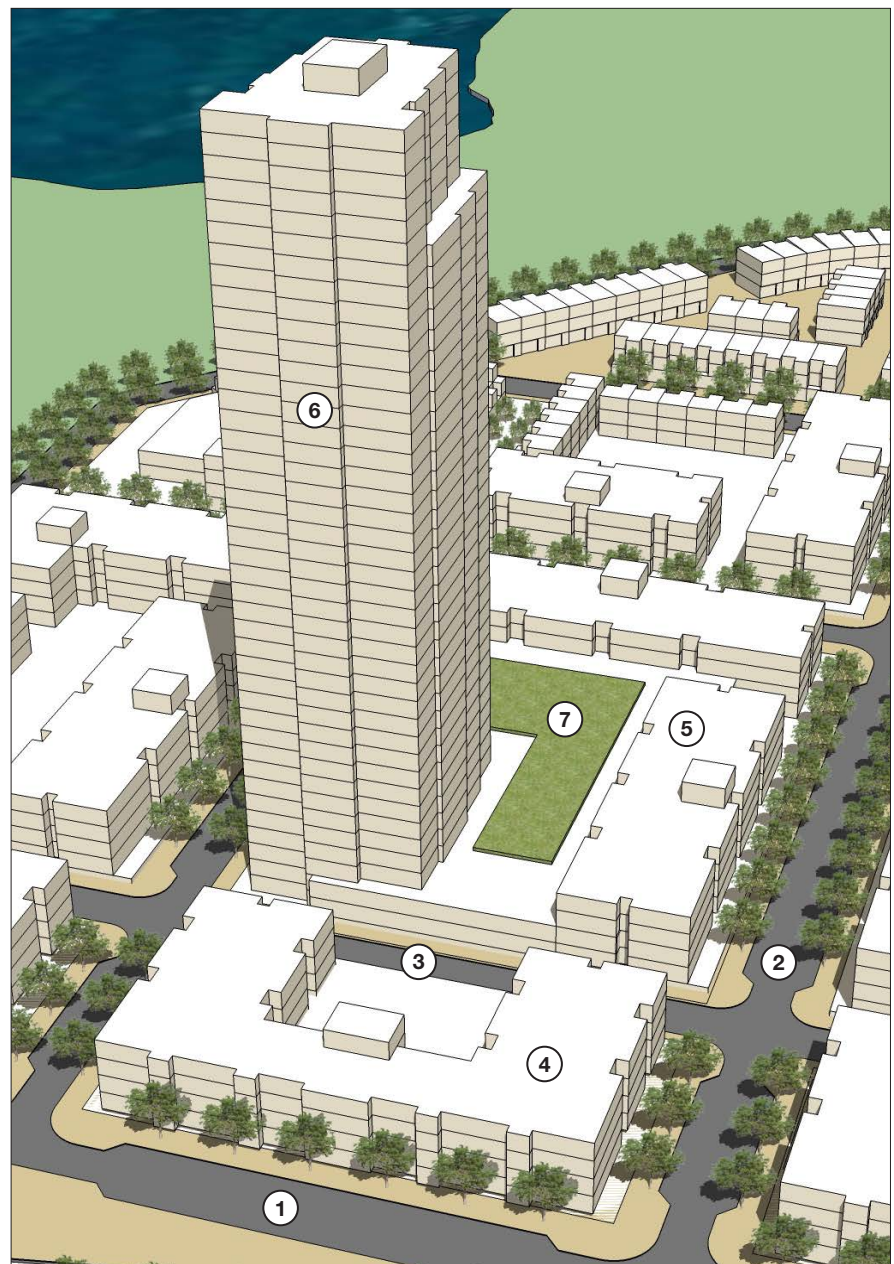
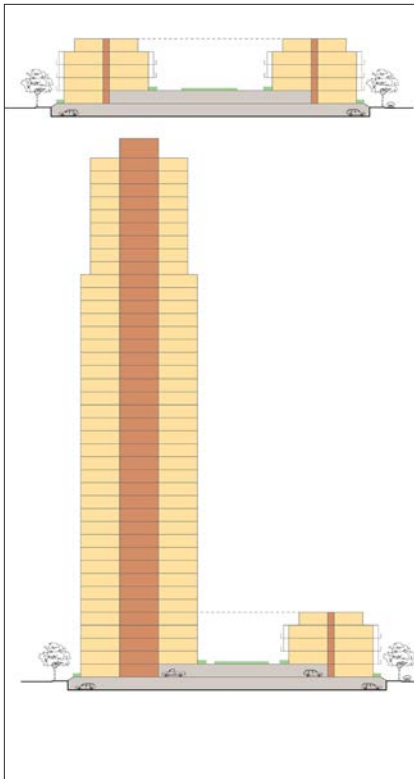

**Legend**

- ① Retail Street
- ② Local Street
- ③ Laneway
- ④ Flats over Retail
- ⑤ Low-rise Flats lining Parking Podium
- ⑥ High-rise Tower
- ⑦ Podium Landscaping





